

- 6.- Damage caused by failure to maintain water chemistry in conformity with the standards of the swimming pool industry for any length of time.
- 7.- Damage caused by water freezing inside the product.
- 8.- Accident damage, fire or other circumstances outside the control of Emaux.
- 9.- Items had been repaired or altered in any way by any person that is not authorized by Emaux.
- 10.- Wear & tear parts.



5.2.- CLAIM PROCESS:

Summary of Emaux Claim Process in 3 steps:

- a) Claim: Customer contacts Emaux salesperson and provides completed details of the claim which includes:
 - a. Information about the failed product such as the part number(s) and serial number(s).
 - b. Description of the complaint/failure.
 - c. Pictures
- b) Once the complaint is received, the product quality incident will then be reviewed by Emaux's Quality Control Department following the "Emaux Warranty Policy".
- c) Conclusion: After the investigation is completed, Emaux will inform the distributor accordingly.

5.3. - WARRANTY OBLIGATION:

Emaux warrants any of above items from workmanship and/or material(s).

Should a defect become evident during the term of warranty, Emaux will, at its option, repair or replace such item or part at its own cost and expense. Customer will need to follow the warranty claim procedures from Emaux in order to obtain the benefit on this warranty.

Emaux is not, however, responsible under this warranty for any cost of shipping or transportation of the equipment or parts thereof "to" or "from" our technical operations.

Emaux is not able to liable for any loss of time, inconvenience, incidental expenses such as labor cost, phone calls, legal cost or material cost incurred in connection with the replacement or removal of the equipment, or any other consequential or incidental damage on persons or assets. Emaux will be not responsible for any business profit loss operation stop due to the non-conformity product equipment. No indemnity or damages can be claimed on any account whatever.

5.4. - WARRANTY OR REPRESENTATIONS BY OTHERS:

No dealer or other person has authority to make any warranty or representation concerning Emaux or its products.

Accordingly, Emaux is not responsible for any such warranty or representation.



WALL RETURN INLETS

MANUAL INSTALLATION.

MODELS:

- EM4408
- EM4409
- EM4410
- EM4413
- EM4414
- EM4415

WALL RETURN INLETS

Model: EM4408; EM4409; EM4410; EM4413; EM4414; EM4415
 Codes: 88094212; 88094312; 88094412; 88094712; 88094812; 88094912

IMPORTANT: This instruction manual includes essential information on the safety measures to be implemented for installation and start-up. Therefore, the installer as well as the user must read the instructions before starting installation and start-up.
Keep this manual for future reference.

1.- WALL RETURN INLET:

Return inlets are one of the most important pool fittings for a proper water recirculation. Two different models of return inlets are available: Wallreturn and Floor return inlets. Wall return inlets are specially designed for those pools with skimmers, since the water recirculation in the pool is “horizontal” from the inlets to the skimmers. On the other hand, the Floor return inlets are recommended to be installed in swimming pools with overflow channel. They prevent dirt from settling by lifting it towards the overflow, creating a “vertical” recirculation.

2.- INSTALLATION:

The positioning of the wall return inlets is important in order to obtain a proper water recirculation and avoid any zone in the pool where water is not circulated periodically. It is recommended to install the Wall return inlets in the opposite side of the skimmers, and 200 - 300 mm. depth from the water surface. (Fig. 1)

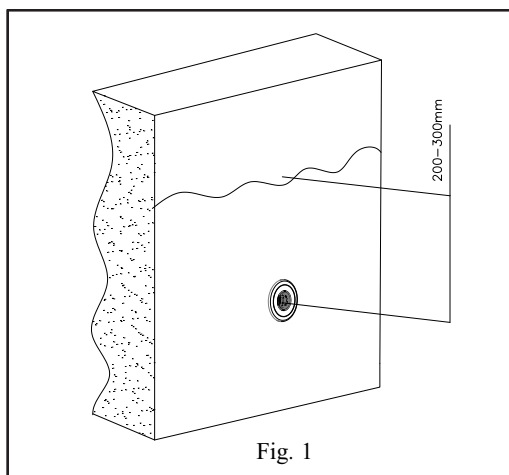

The flow rate required for the installation will determine the number of inlets needed. Three different diameters(14 mm, 20 mm and 25 mm) are available in the eye ball, so you can choose three different flow rates according to the pool requirements:

4.6.- MODEL EM4415

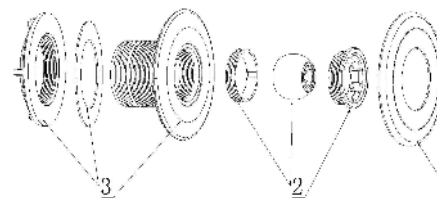

POS.	CODE	PRODUCT DESCRIPTION
1	01050184	Face ring
2	89130105	eyeball locking nut and threaded ring
3	89130110	body (E)
3	89130111	body (A)

5. - WARRANTY POLICY:

Emaux manufactures its products with the highest standard of workmanship, using the best materials available through state of the art process. Emaux proudly warrants its products as follows:

EXTENDED WARRANTY FOR SPECIFIC PRODUCTS (OFFERED FROM DATE OF INVOICE).	
Product	Warranty Period
Filters & Filter Systems	2 years
Pumps	1 year
Underwater Lights	1 year (bulbs 90 days)
Ladders	1 year
Control devices	1 year
Heat Pumps & Heat Exchangers	1 year
Salt Chlorinators & UV Systems	1 year (2 years for cell material)
Pool Fittings	1 year
Cleaning Equipment & All others	1 year

5.1. - EXCEPTIONS THAT MAY RESULT IN DENIAL OF A WARRANTY CLAIM:

- 1.- Damage caused by careless handling, improper repackaging or shipping.
- 2.- Damage due to misapplication, misuse, abuse or failure to operate and install the equipment as specified in this manual.
- 3.- Damage caused by a misuse, abuse or failure to operate and install the equipment out of the scope of a professional level demanded in similar equipment or installation type.
- 4.- Damage due to unauthorized product modifications or failure to use Emaux original replacement parts.
- 5.- Damaged caused by negligence or failure to properly maintain products as specified in this manual.

4.4. - MODEL EM4413:

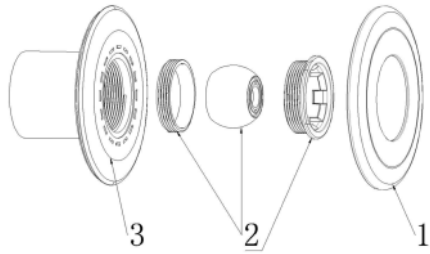
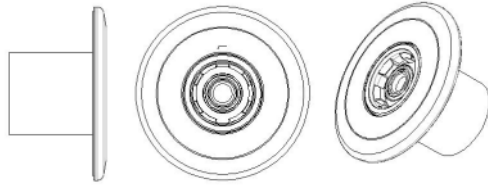

POS.	CODE	PRODUCT DESCRIPTION
1	01050184	Face ring
2	89130105	eyeball locking nut and threaded ring
3	01050193	body(E)
3	01050221	body(A)

4.5. - MODEL EM4414:

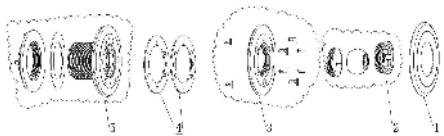
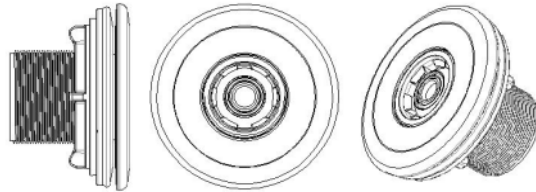

POS.	CODE	PRODUCT DESCRIPTION
1	01050184	Face ring
2	89130105	eyeball locking nut and threaded ring
3	89130107	screws and ring
4	02010280	Joints for liner
5	89130108	body(E)
5	89130109	body(A)

Eyeball Ø 14 mm	Eyeball Ø 20 mm	Eyeball Ø 25 mm
Flow rate 3 m ³ /h	Flow rate 4.5 m ³ /h	Flow rate 7 m ³ /h

Unthread the central piece where the eyeball is placed with one of the tools supplied, and with the other tool (small pipe with Ø20 mm from one side and Ø25 mm from the other side) and a hammer, remove the unwanted parts of the eyeball (Fig. 2).

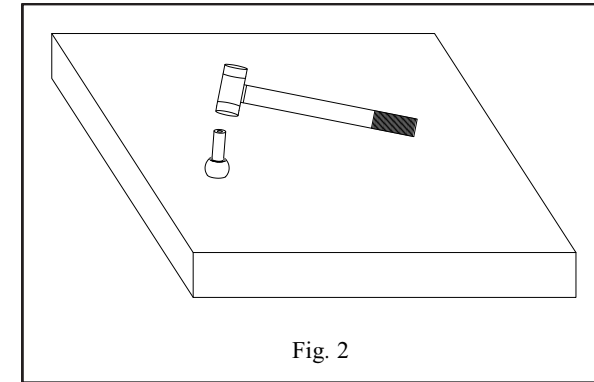

Fig. 2

It is recommended to install the wall conduit model **EM2841** (for concrete pools) or **EM2842** (for Vinyl pools)

3. - MODELS:

	Concrete pools (Fig. 3)			
	EM4408	EM4409	EM4410	EM4413
Metrical connections	Pipe Ø 32 mm Pipe Ø 50 mm PN6	Pipe Ø 50 mm Pipe Ø 63 mm PN6	Pipe Ø 50 mm or thread 2"	Pipe Ø 50 mm
Imperial connections	Pipe Ø 1" Pipe Ø 2" Class 6	Pipe Ø 1.5" Pipe Ø 2.5" Class 6	Pipe Ø 1 1/5" or thread 2"	Pipe Ø 1.5"

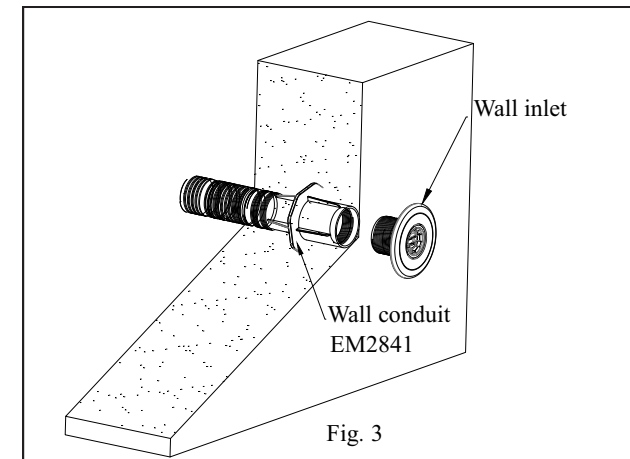
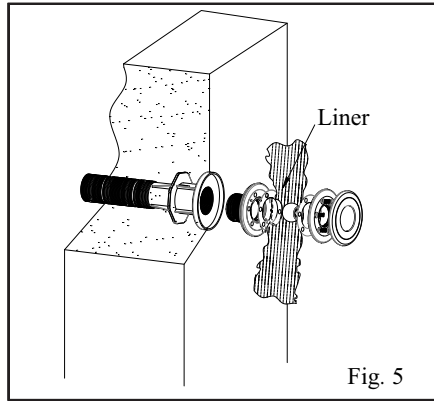
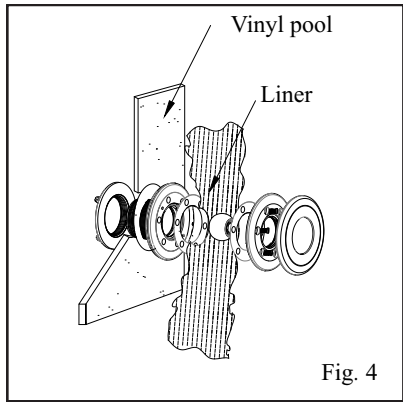

Fig. 3

	<i>Vinyl pools with Liner (Fig 4)</i>	<i>Concrete pools with Liner (Fig. 5)</i>
	EM4414	EM4415
Metrical connections	Pipe Ø 50 mm or thread 2"	Pipe Ø 50 mm or thread 2"
Imperial connections	Pipe Ø 1 1/2" or thread 2"	Pipe Ø 1 1/2" or thread 2"



4.- SPARE PARTS LIST:

4.1.- MODEL EM4408:

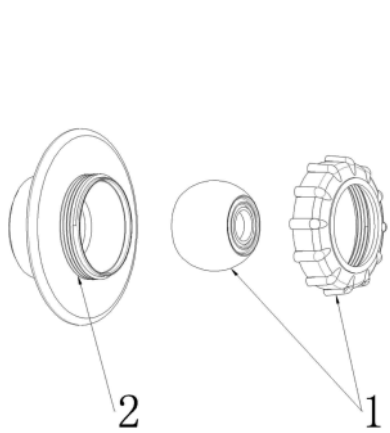

POS.	CODE	PRODUCT DESCRIPTION
1	89130102	Face ring and eyeball
2	01050181	body (E)
2	01050220	body (A)

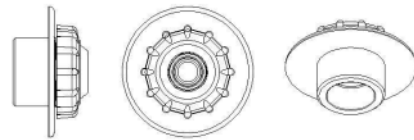

4.2.- MODEL EM4409:

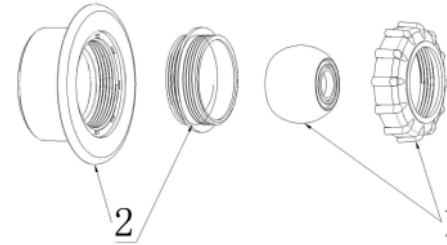

POS.	CODE	PRODUCT DESCRIPTION
1	89130102	Face ring and eyeball
2	89130103	Threaded ring and body (E)
2	89130104	Threaded ring and body (A)

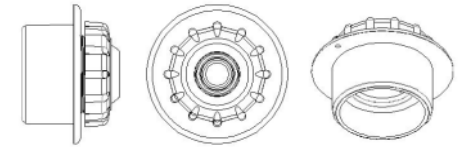

4.3.- MODEL EM4410:

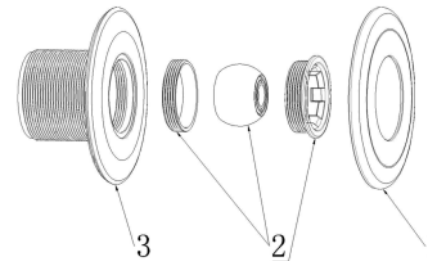

POS.	CODE	PRODUCT DESCRIPTION
1	01050184	face ring
2	89130105	eyeball, locking nut and threaded ring.
3	01050187	body (E)
3	01050218	body (A)

