

**OC 3400 - OX 3100**  
**RC 4100 - RC 4130**  
**RC 4300 - RC 4350**  
**RC 4360 - RC 4370**  
**RC 4400 - RC 4401**  
**RX 4450**

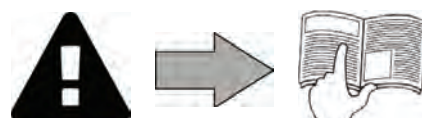

Instructions for installation and use  
English

**EN**





- Before you do anything with the device, it is vital that you read this installation and user manual, as well as the "warnings and warranty" booklet delivered with the device. Failure to do so may result in material damage or serious or fatal injury and will invalidate the warranty.
- Keep and pass on these documents for later consultation during the device's life time.
- It is prohibited to distribute or modify this document in any way without authorisation from Zodiac®.
- Zodiac® is constantly developing its products to improve their quality; therefore, the information contained in this document may be modified without notice.

## CONTENTS



### 1 Specifications

2

1.1 | Description

2

1.2 | Technical specifications and marking

3



### 2 Installation

4

2.1 | Set-up

4

2.2 | Attachment to the base or trolley assembly

5



### 3 Use

6

3.1 | Operating principle

6

3.2 | Pool preparation

6

3.3 | Immersing the cleaner

6

3.4 | Electricity supply connections

7

3.5 | Starting the cleaning cycle

8

3.6 | Ending the cleaning cycle

10



### 4 Maintenance

10

4.1 | Cleaning the filter

11

4.2 | Cleaning the propeller

11

4.3 | Replacing the brushes

12

4.4 | Replacing the tracks

13



### 5 Troubleshooting

14

5.1 | Device behaviour

14

5.2 | User alerts

14



#### **Tip: to make it easier to contact your dealer**

Write down your dealer's contact details to help you find them more easily and fill in the "product" information on the back of the manual; your dealer will ask you for this information.



# 1 Specifications

## 1.1 I Description

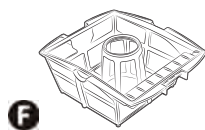
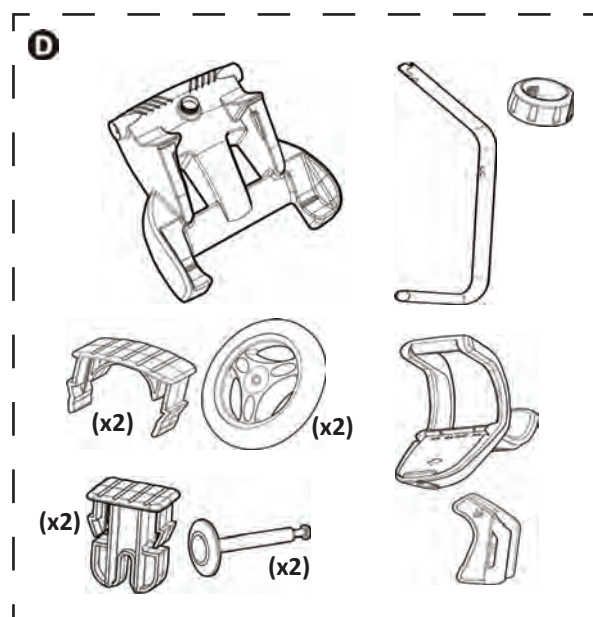
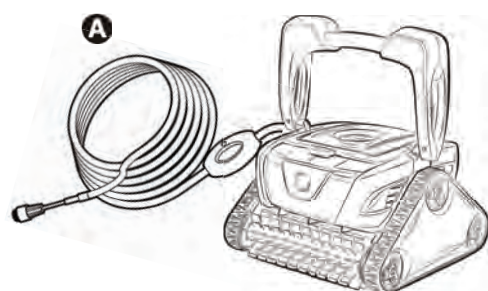







		OC 3400	OX 3100	RC 4100	RC 4130	RC 4300	RC 4350	RC 4360	RC 4370	RC 4400	RC 4401	RX 4450
A	Cleaner A + floating cable	✓		✓	✓	✓	✓	✓	✓	✓	✓	
B	Cleaner B + floating cable		✓									✓
C	Control box	✓	✓	✓	✓	✓	✓	✓	✓	✓	✓	✓
D	Trolley kit	✓	+	✓	✓	+	✓	✓	✓	✓	✓	✓
E	Base for control box		✓			✓						
F	100µ fine debris filter	✓	✓	✓	✓	✓	✓	✓	✓	✓	✓	✓
	200µ large debris filter	+	+	+	+	+	+	+	+	+	+	+
	60µ very fine debris filter	+	+	+	+	+	+	+	+	+	+	+
G	Standard blade brushes	✓	✓	✓	✓	✓	✓	✓	✓	✓		✓
	Blade brushes Polyester casings	+	+	+	+	+	+	+	+	+	✓	+
H	PVA brushes tiling - enamel	+	+	+	+	+	+	+	+	+	+	+
I	Protective cover	+	+	+	+	+	+	+	+	+	+	+

✓ : Supplied

⊕ : Available as an option

EN

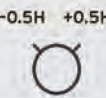
Symbol	Designation	OC 3400	OX 3100	RC 4100	RC 4130	RC 4300	RC 4350	RC 4360	RC 4370	RC 4400	RC 4401	RX 4450
	Start/ Stop the device	✓	✓	✓	✓	✓	✓	✓	✓	✓	✓	✓
	"Control" indicator	✓	✓	✓	✓	✓	✓	✓	✓	✓	✓	✓
	<b>Surface Control System</b> = Surface inspection	✓	✓	✓	✓	✓	✓	✓	✓	✓	✓	✓
	"Clean filter" indicator									✓	✓	
	<b>Surface to clean</b> Bottom only	✓		✓	✓	✓	✓	✓	✓	✓	✓	✓
	Bottom + sides + water line	✓	✓	✓	✓	✓	✓	✓	✓	✓	✓	✓
	Increase / Reduce the cleaning time									✓	✓	

✓ : Available

## 1.2 I Technical specifications and marking

### 1.2.1 Technical specifications

	OX 3100 - RC 4300	RC 4100 - RC 4130 RC 4350 - RC 4360 - RC 4370 - OC 3400 - RX 4450	RC 4400 - RC 4401
Control box power supply voltage	220-240 VAC, 50 Hz		
Cleaner power supply voltage	30 VDC		
Maximum absorbed power	150 W		
Cable length	15 m		18 m
Cleaner size (L x W x h)	41 x 42 x 28 cm		
Package dimensions (L x W x H)	56 x 56 x 38 cm	56 x 56 x 46 cm	
Cleaner weight	9 kg		
Packaged weight	14.3 kg	18.4 kg	
Theoretical cleaning width	220 mm		
Cycle duration (depending on cycles chosen)	1h30 / 2h30		1h-1h30-2h / 2h-2h30-3h

### 1.2.2 Marking

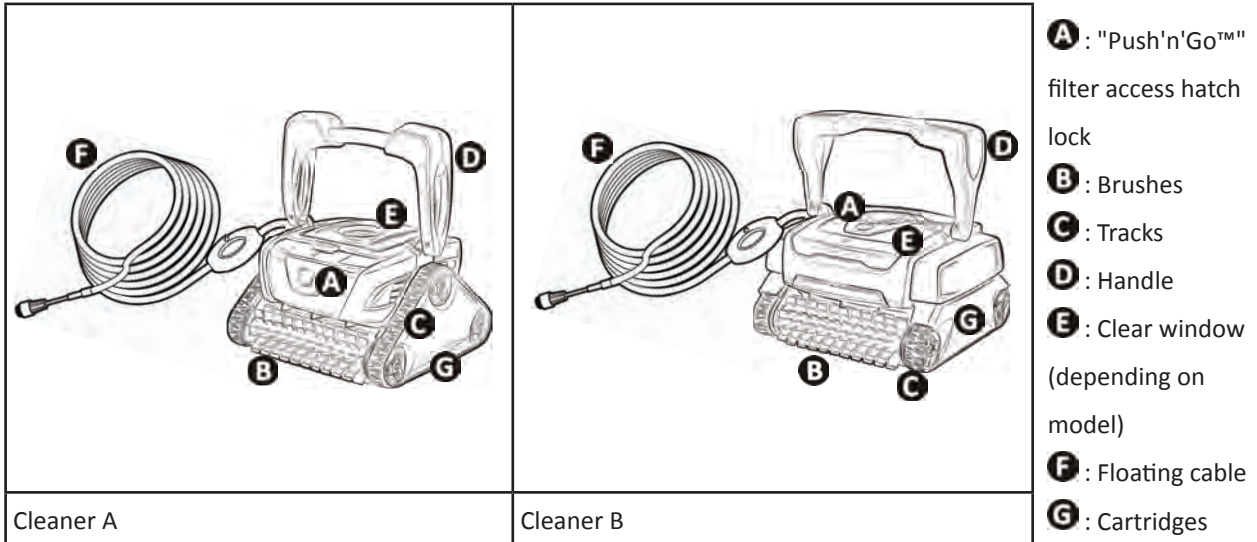

### 1.2.3 Product conformity

This appliance has been designed and built according to the following standards:

**Low voltage directive:** 2006/95/EC

**Electromagnetic compatibility directive:** 2004/108/EC

EN 55014-1: 2000 +A1:2001 +A2:2002; EN 55014-2: 1997 +A1:2002

EN 60335-1: 2002 + A1:2004 + A2:2006 +A11:2004 + A12:2006; EN 60335-2-41: 2003 + A1:2004

Relative to which it is compliant. The product has been tested under the normal conditions of use.

#### SAFETY STANDARDS:

The cleaners are classified by the ETL as being compliant with the appropriate requirements of IEC 60335-2-41.



EN



## 2 Installation

### 2.1 I Set-up

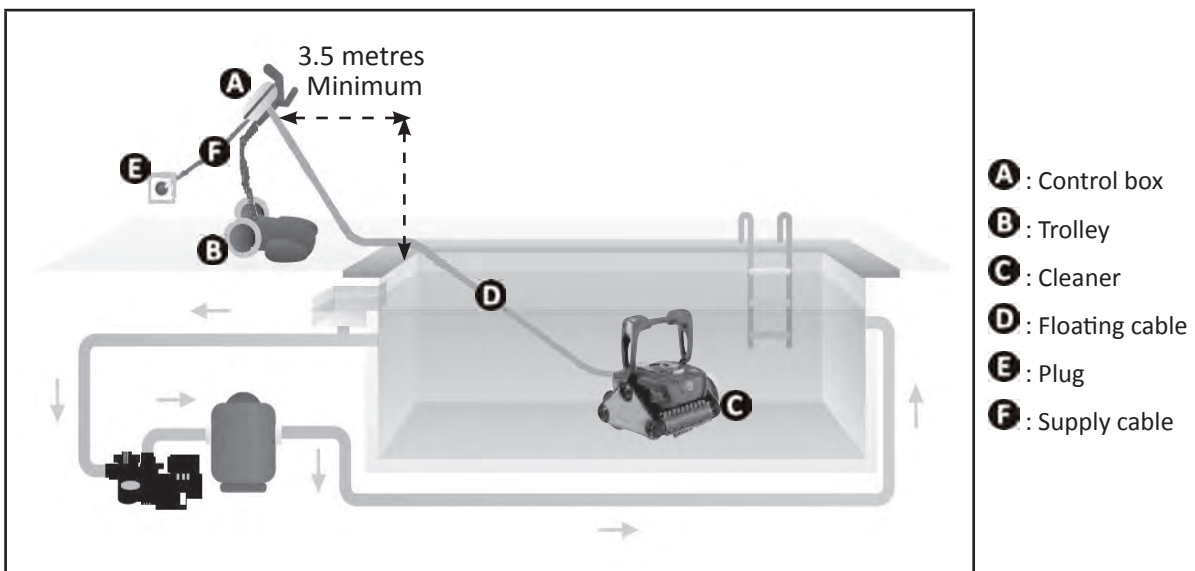



## ➤ 2.2 | Attachment to the base or trolley assembly

### 2.2.1 Attachment to the base

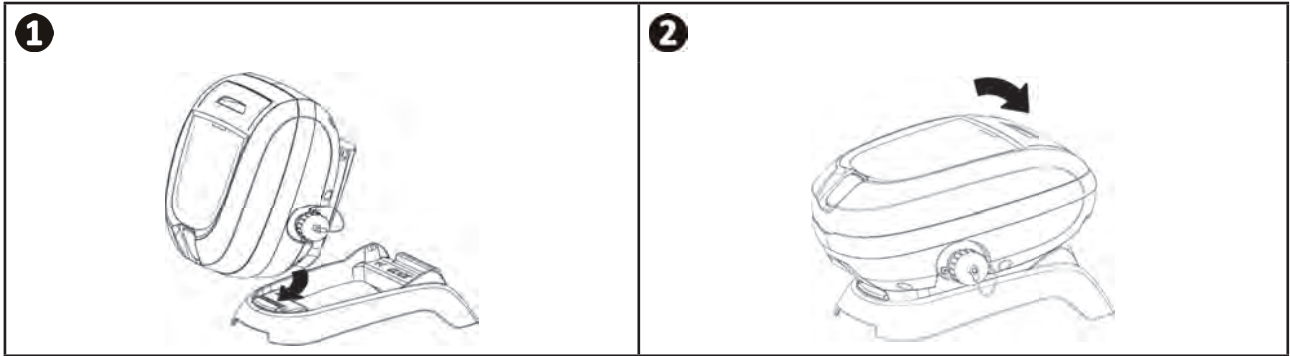

### 2.2.2 Trolley assembly



• Tool-free assembly

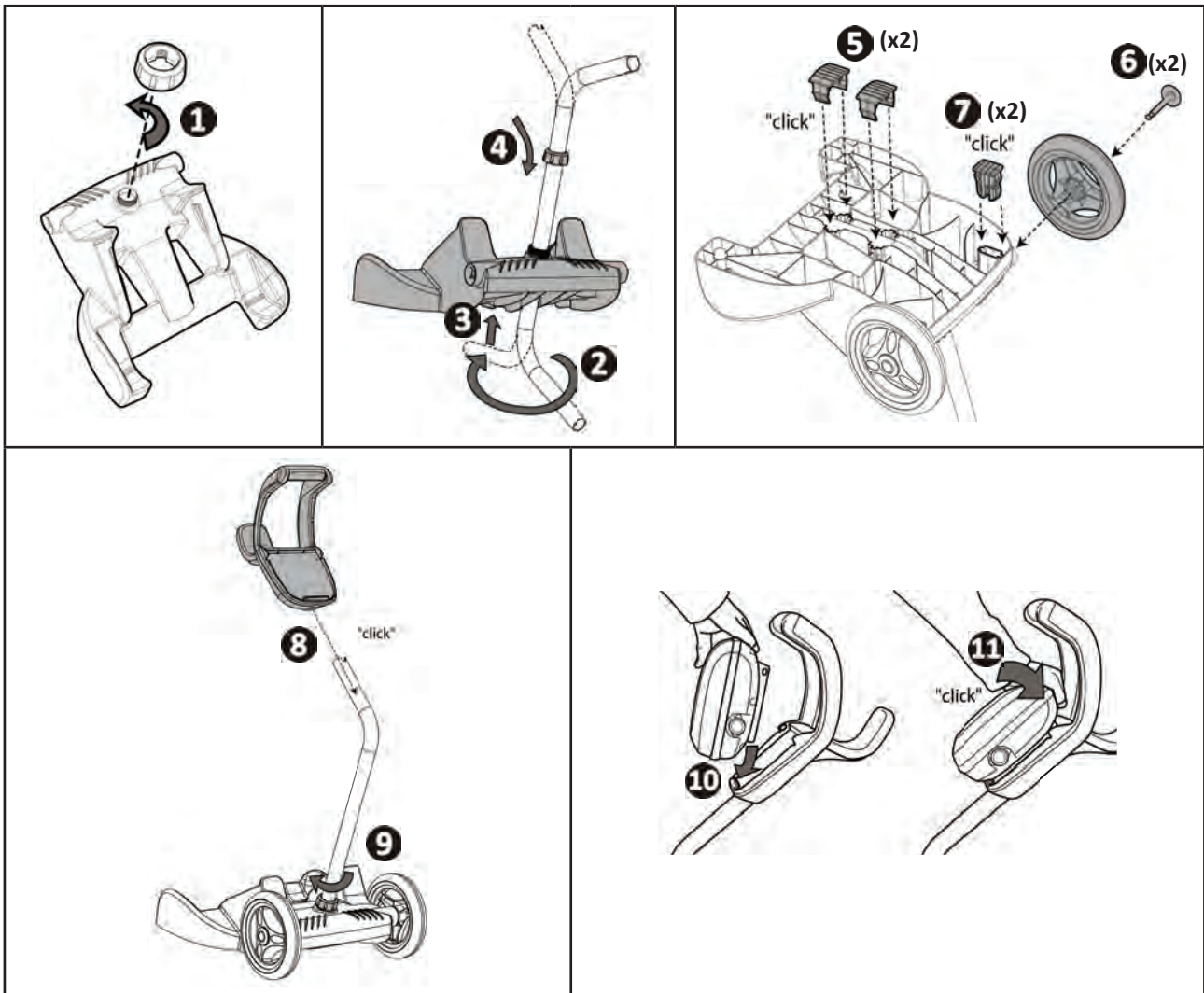



## 3 Use

### 3.1 | Operating principle

The cleaner is independent of the filtration system and simply connected to the mains and so can operate autonomously. It finds the best route to move around and clean the areas of the pool for which it has been designed (depending on the model: bottom, walls, water line). Debris is sucked in and stored in the cleaner's filter.

The control box enables the cleaning operations to be started, selected and programme (depending on the model).

### 3.2 | Pool preparation



- This product is intended to be used in pools which are permanently installed. Do not use it in pools which may be dismantled. A permanent pool is built into the ground or on the ground and cannot be easily dismantled and stored.

- The device must operate in pool water with the following properties:

Water temperature	Between 15°C and 35°C
pH	Between 6.8 and 7.6
Chlorine	< 3 mg/l

- When the pool is dirty, especially when commissioning, remove the largest debris using a net in order to optimise the device's performances.
- Remove any thermometers, toys and other objects that might damage the device.

### 3.3 | Immersing the cleaner

- Roll out the full length of the cable alongside the pool to avoid the cable becoming entangled during immersion (see image 1).
- Place the cleaner vertically into the water (see image 2).
- Move it slightly in all directions so that the air contained in the cleaner escapes (see image 3).
- It is essential that the device sinks on its own and settles on the pool bottom. While it is immersed, the cleaner draws the length of cable it needs into the pool (see image 4).

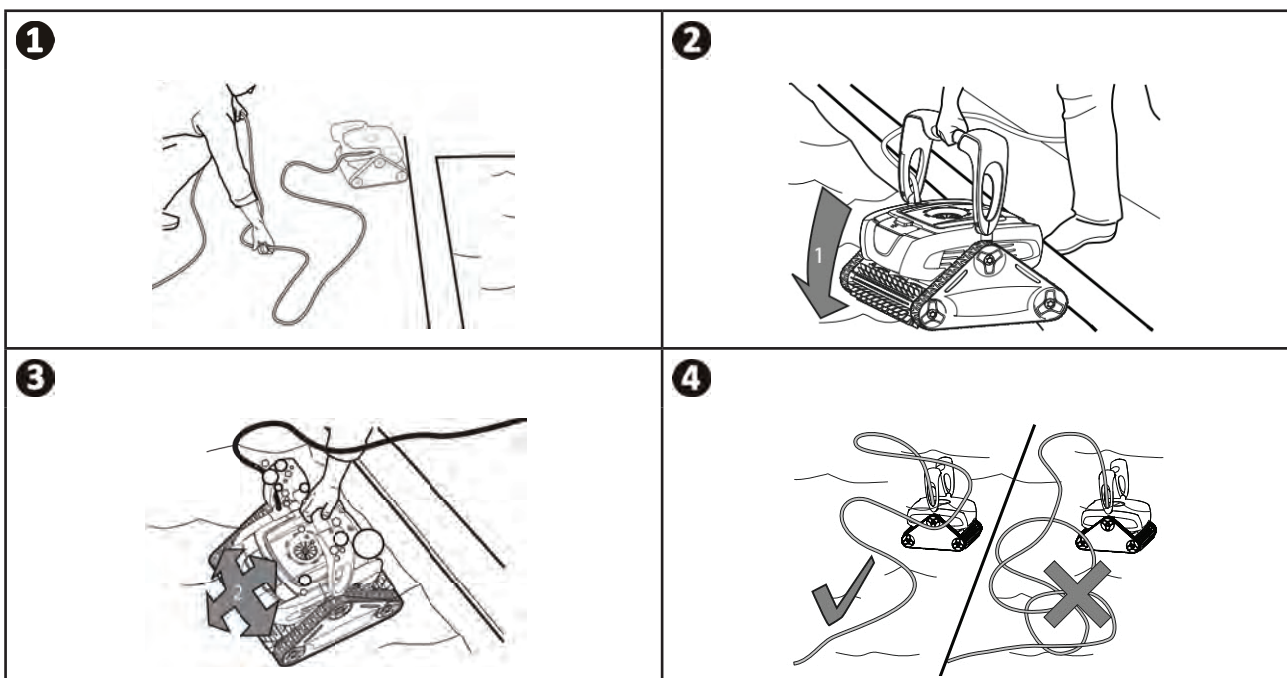

### 3.4 I Electricity supply connections



- Use of an electrical extension is prohibited when connecting the control box.
- Make sure that the socket can be easily accessed at all times and is kept out of rain or splashes.
- The box is splash-proof but must not be immersed. It must not be installed in a floodable area; keep it at least 3.5 metres away from the edge of the pool and avoid exposing it to direct sunlight.
- Place the control box near the socket.

- Connect the floating cable into the control box (see image 1).
- Push the connector in until you hear 2 clicks (see image 2). Make sure the connector is sufficiently pushed into place. If it is not, repeat the operation.
- Connect the supply cable (see image 3). Only connect the control box to a power outlet protected by a 30 mA maximum ground fault circuit breaker (**if in doubt contact a qualified technician**).
- To disconnect the floating cable from the control box, pinch the 2 clips at the end of the connector and pull at the same time (see image 4).

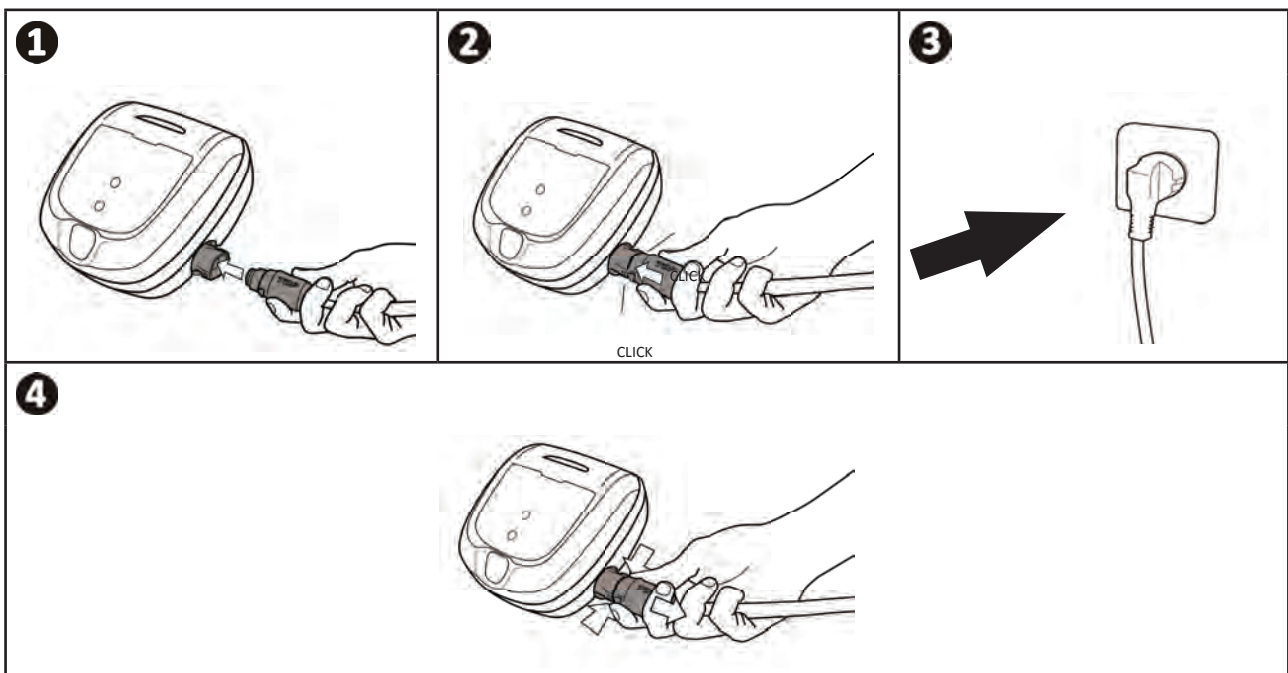

**Tip: box positioning for better operation**

Place the control box in the centre of the pool's length, following the safety conditions relating to electrical connection.



## 3.5 I Starting the cleaning cycle



- Bathing is prohibited when the device is in the pool.
- Do not use the device during shock chlorination.
- Do not leave the device unattended for an extended period.

- When the control box is powered up, the following symbols light up to indicate:
  - The action in progress
  - The cleaning selected (depending on model)
  - Maintenance required
- The control box switches to standby after 10 minutes, and the screen switches off. Just press any key to exit standby mode. Standby mode does not stop the device if it is in a cleaning cycle.

### 3.5.1 Cleaning cycle selection (depending on model)

- A cleaning cycle is already configured by default: the symbols are on.
- The cleaning cycle can be selected at any time, before the device starts or while it is operating. The new cycle will start immediately.
- The cleaner adapts its movement strategy depending on the choice in order to optimise the coverage rate.

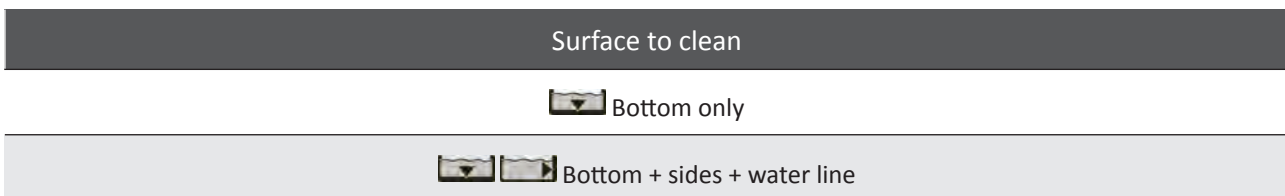

EN

### 3.5.2 Launching the cleaning cycle

- Press



#### **Tip: to improve the cleaning performance**

At the start of the bathing season, launch several cleaning cycles in bottom only mode (after removing the large debris with a net). Regular use of the cleaner (without exceeding 3 cycles per week) means that your pool will always be clean and the filter less clogged.

### 3.5.3 Adjusting the cleaning time (depending on model)



- You may reduce or increase the cleaning time at any time (+/- 0.5 H).

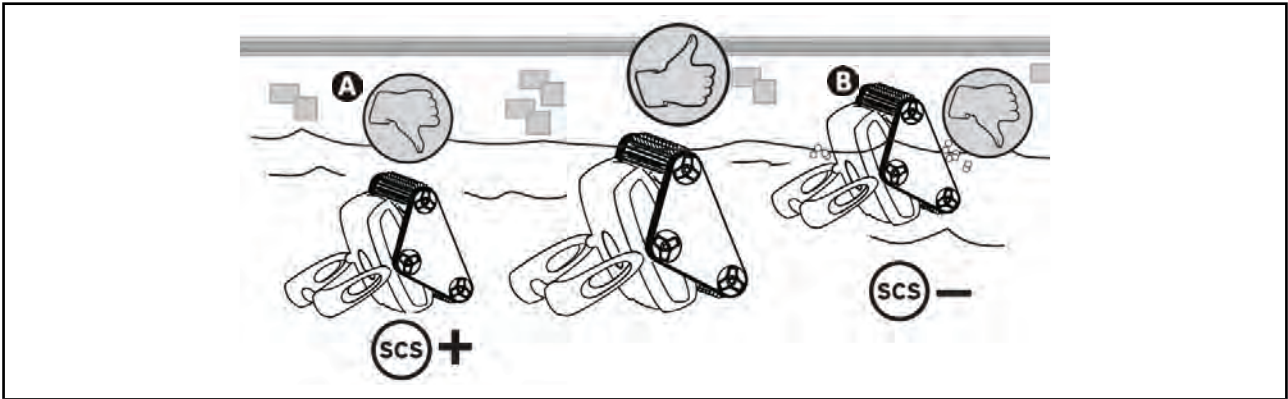

### 3.5.4 Surface control

- Check that the cleaner filter is clean so as not to affect the cleaner's behaviour.
- Once the cleaning cycle has been launched, monitor the cleaner's behaviour when climbing the walls and when it brushes the water line.
- You can use the **SCS** (Surface Control System) button at any time depending on the cleaner's behaviour: **see the following table.**
- The new configuration will be effective the next time the cleaner climbs the walls.
- 2 LEDs are lit by default .

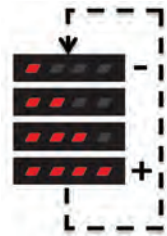

	Cleaner behaviour to be observed	Meaning	Action
<b>A</b>	The cleaner climbs the walls slowly and stops under the water line. <b>Increase the number of LEDs.</b>		Press: 
<b>B</b>	The cleaner climbs the walls quickly and goes past the water line until it sucks in air: <b>Reduce the number of LEDs.</b>		

**Tip: Optimise wall cleaning and water line brushing operations**

According to the type of pool lining, the cleaner will behave differently when climbing the walls. The cleaner



has the **SCS** function to optimise **wall cleaning, then the water line brushing** on all types of lining.

However the **SCS** function is set, the suction power remains at its maximum at all times when the cleaner is moving across the bottom of the pool.

### 3.6 I Ending the cleaning cycle



- Only use the handle to remove the cleaner from the water. Do not lift the cleaner using the floating cable.
- Do not leave the device to dry out in sunlight after use.
- Store all the elements away from sunlight, dampness and bad weather.

- Switch off the device by pressing .
- To bring the cleaner to the edge of the pool, pull on the floating cable.
- When the cleaner is within arm's reach, pick it up by the handle and lift it gently out of the pool so that the water it contains drains into the pool (see image **1** and **2**).
- Place the cleaner vertically at the location provided on the trolley (depending on the model) for it to dry out quickly (see image **3**).
- Then store it with the command box away from sunlight and any splashing. A protective cover is available as an option (see image **4**).

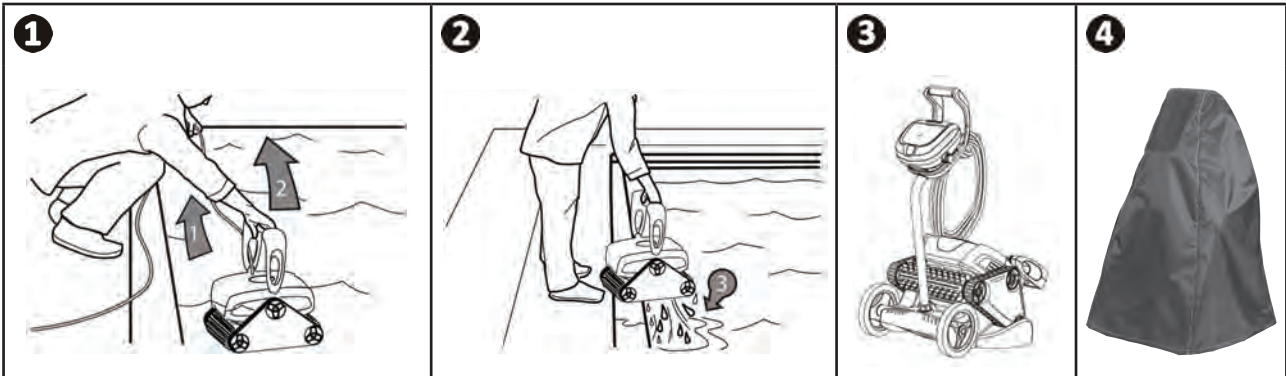

#### **Tip: prevent the floating cable from becoming too entangled**

The cleaner's behaviour is strongly impacted by the tangling of the cable. A cable which is correctly untangled will guarantee better coverage of the pool.



- Untangle the cable and lay it out in the sun so that it returns to its original shape.
- Then wind it up carefully and place it on the trolley handle (depending on the model) or on a fixed support.



## 4 Maintenance

- The device must be cleaned regularly using clean or slightly soapy water. Do not use any solvents.
- Rinse the device generously using clean water.
- Do not let your device dry in the sun by the pool.



#### **Tip: replace the filter and the brushes every 2 years**

You are recommended to change the filter and the brushes every 2 years to preserve the integrity of the device and guarantee optimum performance.

## ➤ 4.1 | Cleaning the filter



- The cleaner performance may be reduced if the filter is full or dirty.
- Clean the filter regularly with clean water for efficient pool cleaning.

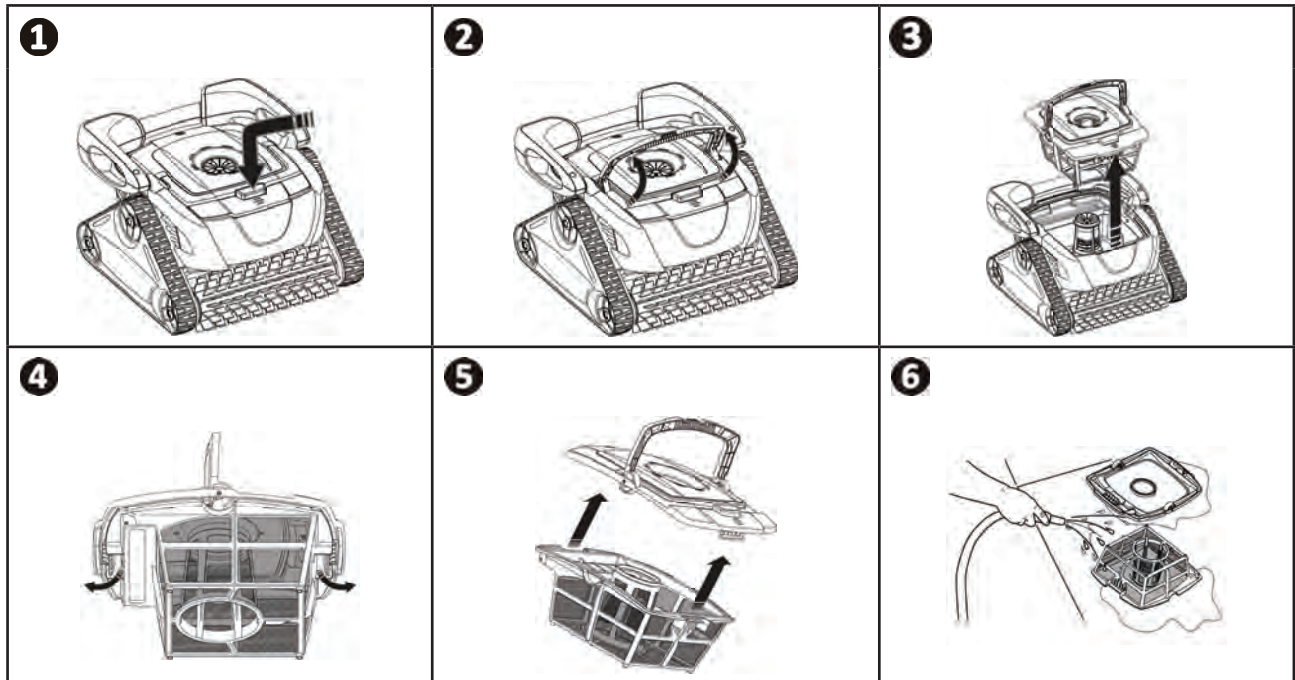

## ➤ 4.2 | Cleaning the propeller



To avoid serious injury:

- Disconnect the cleaner from the power.
- Wear gloves when handling the propeller



- Loosen the screw on the grill (see image **1**).
- Remove the grill carefully (see image **2**).
- Wear gloves and pull on the propeller while holding it tightly (see image **3**). Remove all debris (leaves, stones, etc.) which may be blocking the propeller.

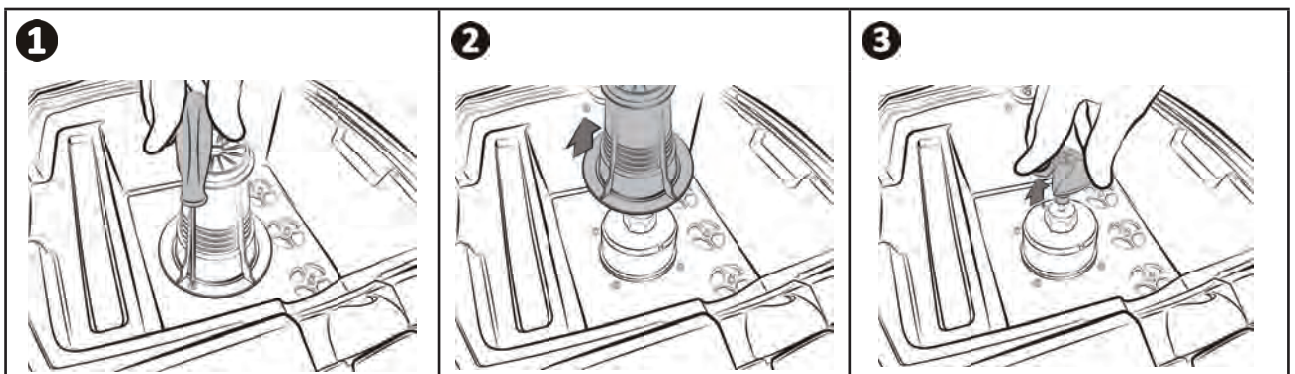

### ➤ 4.3 I Replacing the brushes

- The brushes have wear indicators (see image **1**).
- To remove worn brushes, remove the tabs from the holes in which they are fixed (see image **2**).
- To fit new brushes, start by fitting the side without tabs under the brush holder (see image **3**).
- Roll the brush around its support, slide the tabs into the attachment holes and pull on the end of each tab until its edge passes through the slit (see image **4**).
- Cut the tabs using a pair of scissors for them to be level with the other blades (see image **5**).

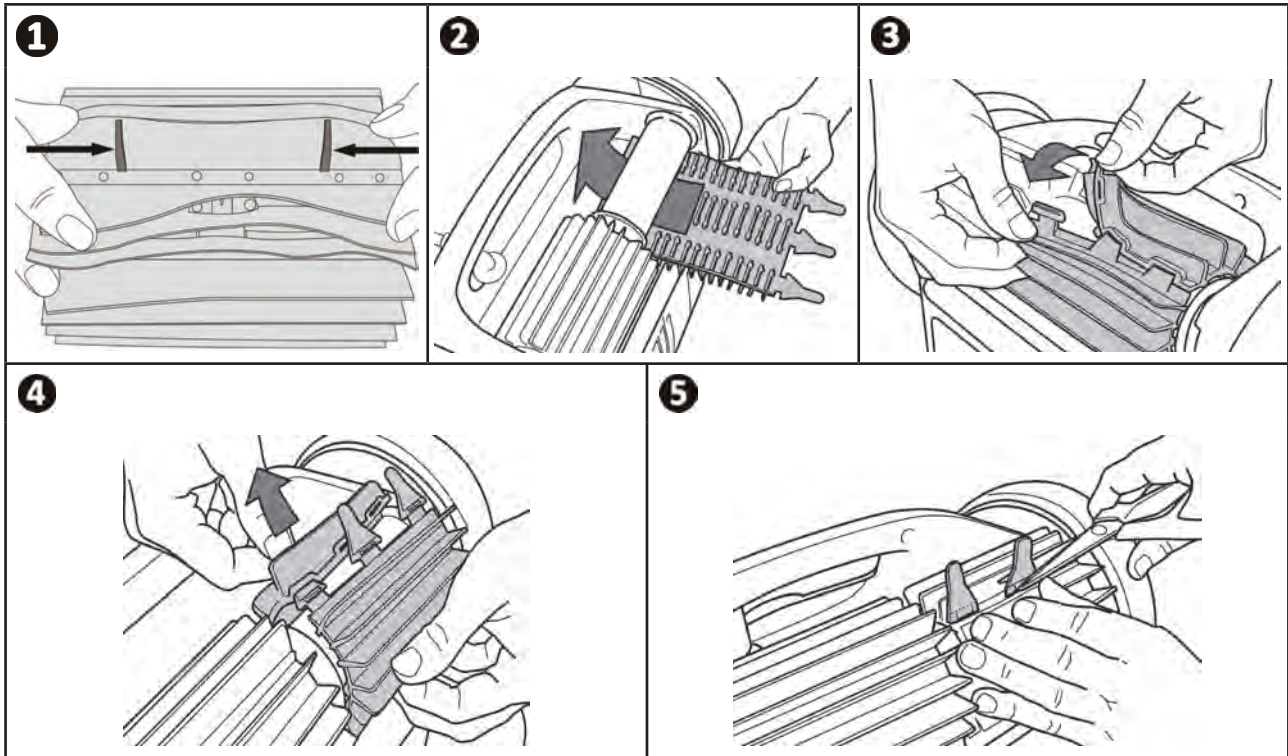



## 4.4 I Replacing the tracks



- For OX 3100 - RX 4450 cleaners, the tracks must be replaced by the dealer.

- Place the cleaner on its side (see image **1**).
- Starting with one of the wheels, pull the inside of the track to separate it from the wheel (see image **2**). Then remove the track from the cleaner.
- To install the new track, position the inside of the track on the first wheel's grooves (see image **3**).
- Stretch the track around the second wheel, then around the last one. Press down on the track to position it correctly on the wheel grooves (see image **4**). Make sure that the track passes under the guides (see image **5**).

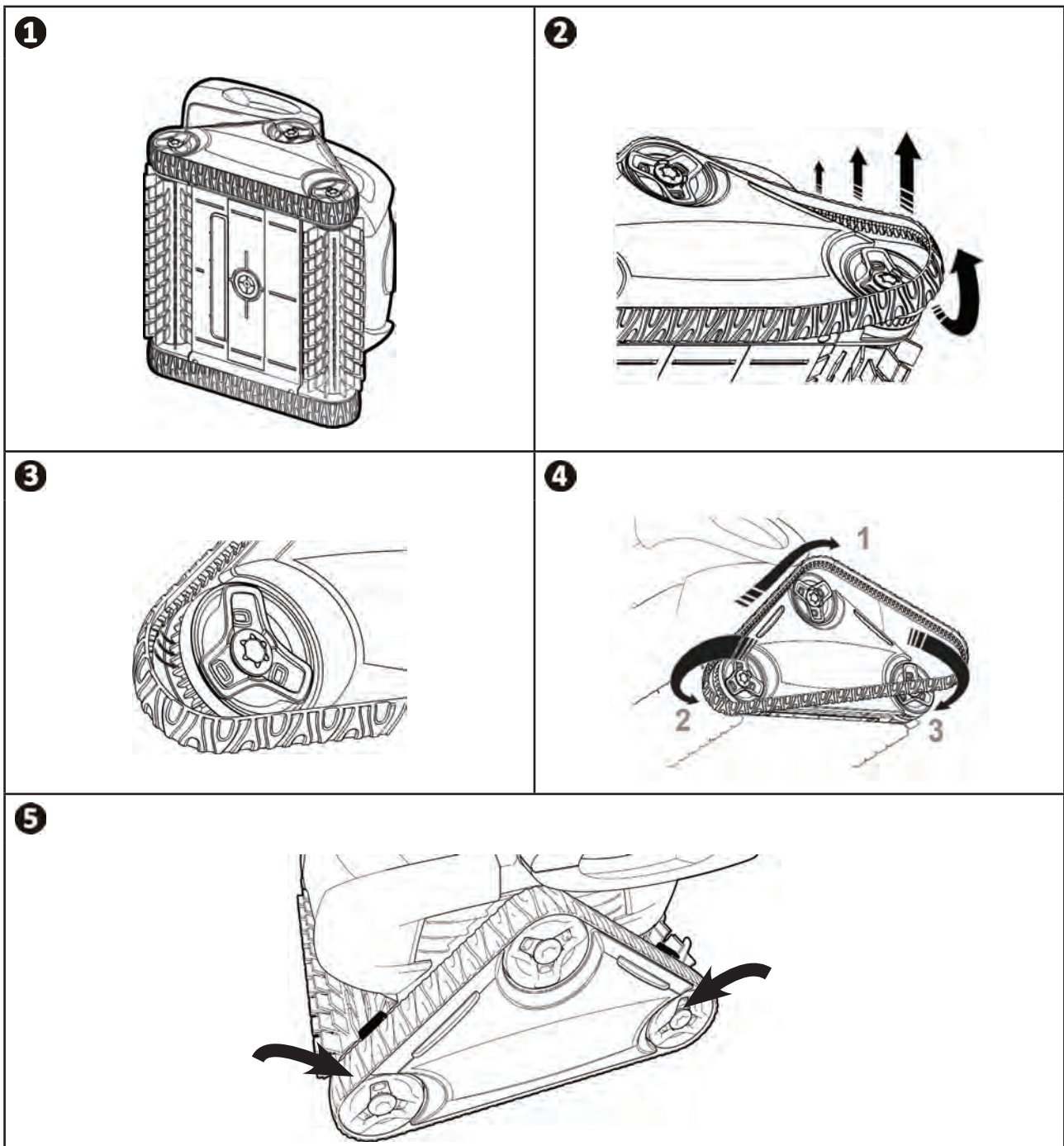





## 5 Troubleshooting





- Before you contact your dealer, please carry out these few simple checks using the following tables if a problem occurs.
- If the problem continues contact your dealer.
-  : Actions reserved for a qualified technician

### 5.1 I Device behaviour

While operating, the cleaner does not stay firmly on the pool bottom	<p><b>This may have 3 causes:</b></p> <ul style="list-style-type: none"> <li>• There is still air in the appliance's casing. Repeat the cleaner immersion operations (see § "3.3 I Immersing the cleaner").</li> <li>• The filter is full or dirty: all you have to do is clean it.</li> <li>• The propeller is damaged, <b>contact your dealer:</b> </li> </ul>
The cleaner does not or no longer climbs the pool sides	<p><b>This may have 2 causes:</b></p> <ul style="list-style-type: none"> <li>• The filter is full or dirty: all you have to do is clean it.</li> <li>• Even though the water seems clear, microscopic algae are present in your pool, they are not visible to the naked eye, and they make the sides slippery and prevent the cleaner from climbing. Carry out shock chlorination and slightly reduce the pH. <b>Do not leave the cleaner in the water during shock treatment.</b></li> </ul> <p><b>If the problem continues contact your dealer:</b> </p>
The cleaner does not perform any movements on start-up.	<ul style="list-style-type: none"> <li>• Check that the outlet to which the control box is connected is receiving a power supply.</li> <li>• Check that you have started a cleaning cycle and check that the indicators are on.</li> </ul> <p><b>If the problem continues contact your dealer:</b> </p>
The cable gets tangled	<ul style="list-style-type: none"> <li>• Do not unroll the entire length of the cable into the pool.</li> <li>• Place the required length of cable in the pool and place the rest on the side of the pool.</li> </ul>
The control unit does not respond when you press the buttons	<ul style="list-style-type: none"> <li>• Unplug the cable from the mains socket, wait 10 seconds and plug it back in again.</li> </ul>

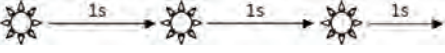
### 5.2 I User alerts

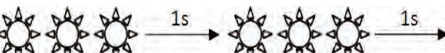
Flashing LED: 	Solutions
	<ul style="list-style-type: none"> <li>• Check that the cleaner is correctly connected to the control box. If necessary, unplug it and reconnect it following the appropriate procedure.</li> </ul>
	<ul style="list-style-type: none"> <li>• Check that there is nothing preventing the brushes and wheels from turning. To do so, turn the wheels (1/4 turn) to release any debris that may be jammed.</li> </ul>
	<ul style="list-style-type: none"> <li>• Cleaner operating outside the pool. Make sure you start the cleaner when it is in the water (see § "3.3 I Immersing the cleaner").</li> <li>• Check that there are no stones or hair in the propeller.</li> <li>• Clean or change the filter if necessary.</li> </ul>



**Tip: if you require assistance, inform your dealer about the device's condition to save time**  
Provide this information to your dealer