

BADU® OmniTronic - Upgrade

Universal automatic backwash unit for almost every application.
Simple and flexible operation.

Field of application

Depending on the size and load, filter units have to be backwashed on a regular basis in order to wash away debris that has been filtered in. The BADU OmniTronic electronic backwash device is a reliable and time-saving alternative to manual backwash valves.

Mode of operation

A digital timer starts the backwash procedure automatically according to the settings of the interval or time controlled programme. Filter time settings can also be specified.

An automatic level control is integrated and can be used with an optionally available level sensor and magnetic valve.

A small circuit board attachment is optionally available for conductive level control (conductivity).

A battery pack prevents the pool from emptying in the event of a power failure.

Performance features

- The performance features of the new BADU OmniTronic have been enhanced by a larger housing box, which now also offers space for additional onsite modules.
- Small top hat rail (15 mm) provided for components.
- BADU GREEN pumps, such as the BADU Delta Eco VS, can be connected directly to the backwash device.
- Level controls with optional sensors.
- All six valve positions can be accessed.
- Various inputs and outputs with additional functions e.g. pressure switch trigger and remote control.
- Operation in combination with a dosage control system possible.

Technical data	BADU	OmniTronic
Circuit board		microprocessor controlled
Operating voltage		1~ 230 V, 50 Hz
Connection value (motor capacity P ₁)		max. 1.00 kW
Fuse, for electronics/pump		315 mA delay/4 A delay
Max. permissible load current		250 V/4 A
Operating pressure		max. 2 bar
Net weight (kg)		4.00

For more detailed information regarding the device protection please see page 143.

Technical data may vary.

Article no	Description	Connections	Voltage
260.6000.041	BADU OmniTronic with BADU Mat R 41/3 A	Rp 1½	1~ 230 V
260.6000.051	BADU OmniTronic with BADU Mat R 51/3 A	Rp 2	1~ 230 V
260.6402.087	Pressure transducer +500.. +1500 mbar, incl. assembly accessories for pressure-controlled backwashing		
260.6402.088	Pressure transducer +0,25.. +1,00 bar, incl. incl. assembly accessories for pressure-controlled enable signal		
260.6402.204	Additional feature: Control of floor drain		
260.6402.205	Additional feature: Control of single phase pumps up to 6.40 A		
260.6402.206	Additional feature: Control of three-phase pumps with 1.00 A		
240.9102.063	Special non-return valve ¹⁾ d 63		
271.6090.025	Level switch with 10 m cable and bracket		
260.6402.117	Temperature sensor with 5 m cable and PVC mount		
260.6402.118	Temperature sensor with 15 m cable and PVC mount		
260.6402.159	Additional circuit board for conductivity sensor		
260.6402.161	Conductivity sensor, 5 m		
260.6402.157	Battery pack with capacitor		

¹⁾ For sewage pipes when the BADU OmniTronic is installed **below** the water level.

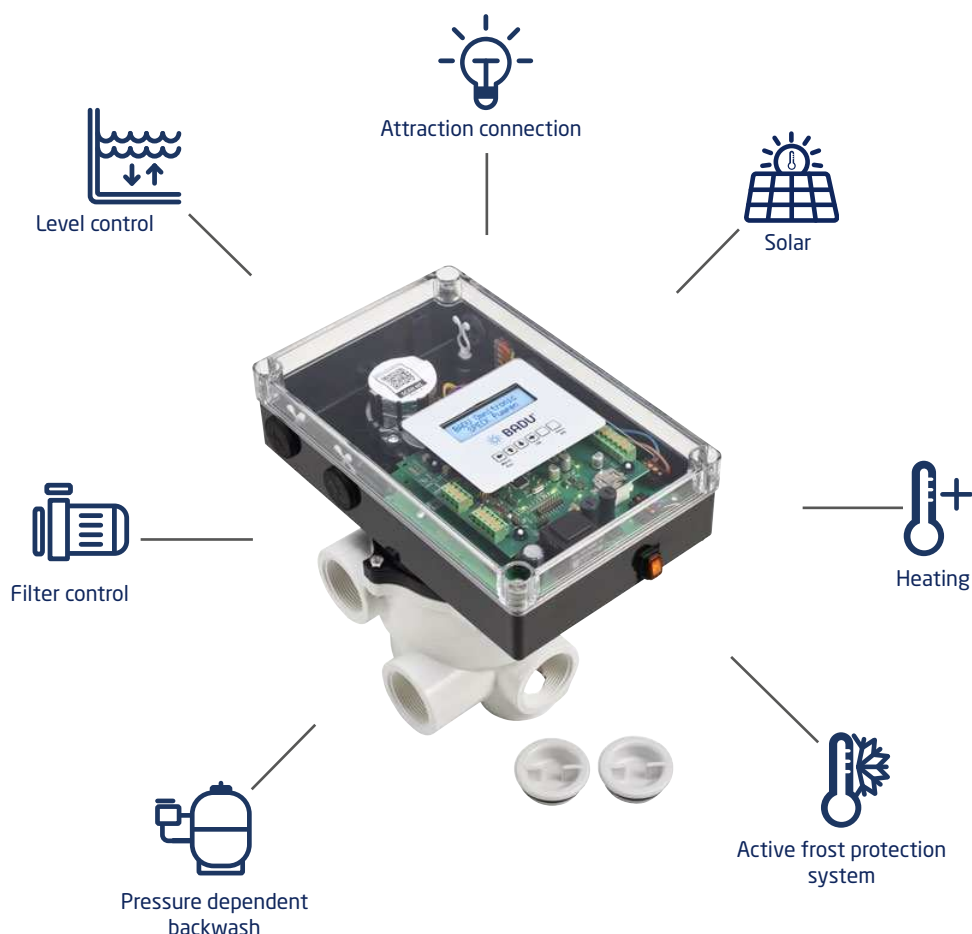

Product details

Switching functions

- Automatic backwash and filtering.
- Backwash and rinse cycles can be started automatically, manually or externally and set individually.
- BADU GREEN pumps can be connected directly.
- Magnetic valve can be controlled optionally (level control).
- Can be used optionally as a temperature and level control.

Optional additional modules

- For direct connection of single-phase pumps via a contactor e.g. BADU Prime 7 to BADU Prime 20.
- For direct connection of three phase pumps via three phase protection and a contactor e.g. BADU Prime 7 to BADU Prime 25.
- Insert option for a circuit board that controls the floor drain.

Installation tip

Do not install lower than 3 m below water level.
 Lead the sewage pipe above the water level in a loop.
 In case this is not feasible, install a spring-loaded non-return valve in the sewage pipe.
 Too large temperature differences (>20 K) between the environment and the pumped medium lead to condensation.

Generally valid: The pump may only be switched on if the BADU OmniTronic is not changing the valve position. The arrow in the display should point downwards. The digital inputs must be switched on for BADU Eco VS pumps.

Dimensions

Detailed dimensions available on request or at badu.de

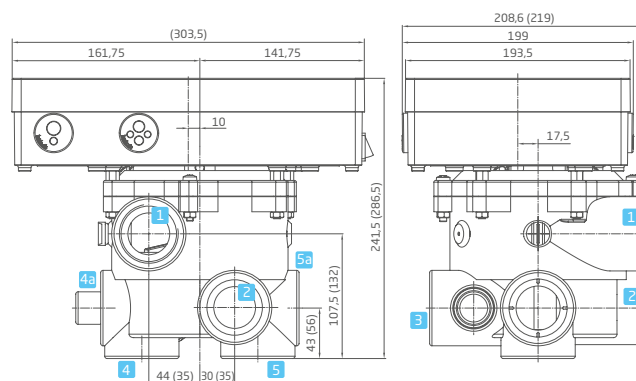

- 1 Pump
- 2 Pool
- 3 Sewage
- 4 / 4a to the filter
- 5 / 5a from the filter

The measurements in brackets are for BADU OmniTronic with BADU Mat R 51/3 A.