

1 INCH HIGH PRESSURE VALVE

REPLACEMENT PARTS

Item	Part No.	Description	Qty
1	01013042	Handle	1
2	03018010	Pin for Handle	1
3	01181001	Washer for Handle	1
4	01270002	1" High-Pressure Valve Cover	1
5	89281203	M6 x 25 Screw with Nut	8
6	89281202	1" High-Pressure Valve Air Release Valve with O-Ring	1
7	89280120	Drain Plug Fitting with O-ring	1
8	89021307	Drain Plug with O-Ring	1
9	01181002	Washer for Spring	1
10	02010001	O-Ring for Rotor	2
11	03014014	Spring for Valve	1
12	01021005	Rotor	1
13	02011012	Spider Gasket	1
14	02011144	O-Ring for 1" High-Pressure Valve Body	1
15	01020008	1" High-Pressure Valve Body Assembly	1
16	89280104	Sight Glass with O-Ring	1
17	01013043	Diffuser	1
18	02011016	O-Ring for Diffuser	1

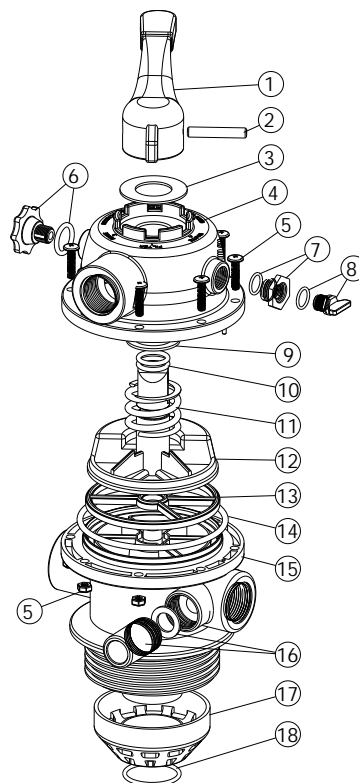

FUNCTIONS OF VALVE POSITIONS

Valve Position	Function
FILTER	Normal Filtration
BACKWASH	Cleaning Filter by reversing the flow
RINSE	Used after backwash to flush dirt from valve
WASTE	By-passes filter, used for vacuuming to waste or lowering water level
RECIRCULATE	By-passes filter for circulating water to pool
CLOSED	Shuts off all flow to filter or pool

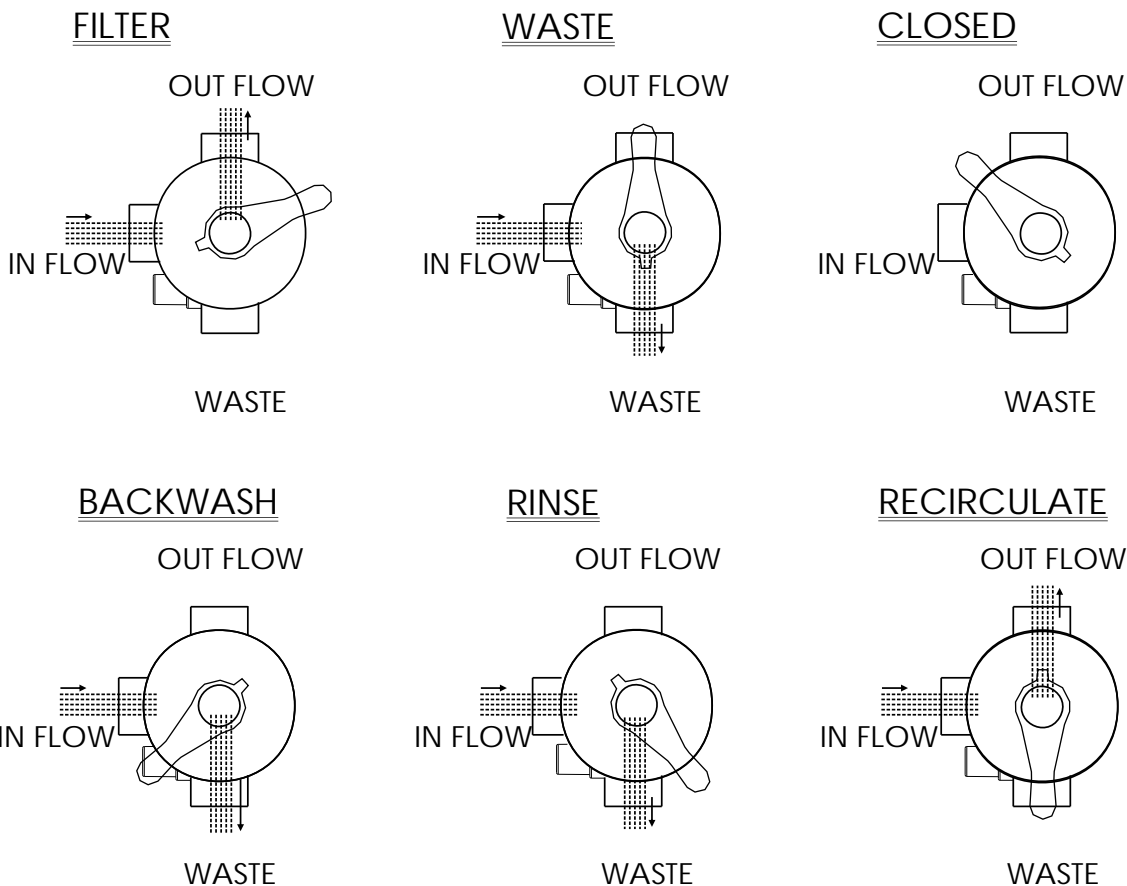

GENERAL

- 1) Pipe tap boss provided for optional influent pressure gauge.
- 2) SERVICING VALVE(Stop pump,close gate valve in suction&discharge before proceeding):
 - a) Set handle in filter position.
 - b) Remove cover screws.
 - c) Lift cover and key assembly out.

TO ASSEMBLE:

- d) Place valve key so that wedge opening is at TOP port (handle in Filter psn.). Flat edge of cover screw lug should align with flat edge of body screw lug.
- e) Position cover O'Ring.
- f) Secure assembly to body with cover screws. Tighten cover screws evenly and alternately. Do not over-tighten.