

## PARTS FOR FILTER MAX FILTER

Key NO.	Part Number	Product Description	QTY
1	89010701	Air Release Valve	1
2	06021002	Plastic Pressure Gauge With O-Ring (40psi)	1
3	01111048	Connector for Pressure Gauge/Stopper	1
4	01201022	Lid (Transparent)	1
5	01271021	Clamp Lock (left)	1
6	01271022	Clamp Lock (right)	1
7	03021035	M6 Nut	1
8	01111101	Star-Shaped Nut	1
9	03011166	M6×110mm Screws	1
10	03018124	Pin	1
11	02010007	O-Ring	1
12	01331036	MFS17 Filter Tank	1
	01331037	MFS20 Filter Tank	1
	01331038	MFS24 Filter Tank	1
	01331049	MFS27A Filter Tank	1
	01331039	MFS27 Filter Tank	1
	01331050	MFS31A Filter Tank	1
	01331040	MFS31 Filter Tank	1
	01331041	MFS35 Filter Tank	1
13	86280805	1.5" Side Mount Valve for MFS17 MFS20 MFS24 MFS27A MFS31A Filter MAX	1
	86280806	2.0" Side Mount Valve for MFS27 MFS31 MFS35 Filter MAX	1
14	01015002	1.5" Connecting nut for MFS17 MFS20 MFS24 MFS27A MFS31A Filter MAX	2
	01015003	2.0" Connecting nut for MFS27 MFS31 MFS35 Filter MAX	2
15	02011003	O-Ring for valve connection for MFS17 MFS20 MFS24 MFS27A MFS31A Filter MAX	2
	02020016	O-Ring for valve connection for MFS27 MFS31 MFS35 Filter MAX	2
16	02010009	Spacer for Connecting panel for MFS17 MFS20 MFS24 MFS27A MFS31A Filter MAX	1
	02010010	Spacer for Connecting panel for MFS27 MFS31 MFS35 Filter MAX	3
17	01172033	1.5" Connecting panel for MFS17 MFS20 MFS24	1
	01172002	1.5" Connecting panel for MFS27A MFS31A	1
	01170014	2.0" Connecting panel for MFS27 MFS31 MFS35	1
18	89012611	Air Vent Pipe for MFS17	1
	89012612	Air Vent Pipe for MFS20	1
	89012613	Air Vent Pipe for MFS24	1
	89012614	Air Vent Pipe for MFS27A MFS27	1
	89012615	Air Vent Pipe for MFS31A MFS31	1
	89012616	Air Vent Pipe for MFS35	1
19	89012601	MFS17 Top part of the inner tank system	1
	89012602	MFS20 Top part of the inner tank system	1
	89012603	MFS24 Top part of the inner tank system	1
	89012604	MFS27A Top part of the inner tank system	1
	89012617	MFS27 Top part of the inner tank system	1
	89012605	MFS31A Top part of the inner tank system	1
	89012618	MFS31 Top part of the inner tank system	1
	89012619	MFS35 Top part of the inner tank system	1
20	01111046	1.5" Tank System Support for MFS17 MFS20 MFS24	1
	01111043	1.5" Tank System Support for MFS27A MFS31A	1
	01110018	2.0" Tank System Support for MFS27 MFS31 MFS35	1
21	89012606	MFS17 Bottom part of the inner tank system	1
	89012607	MFS20 Bottom part of the inner tank system	1
	89012608	MFS24 Bottom part of the inner tank system	1
	89012609	MFS27A Bottom part of the inner tank system	1
	89012620	MFS27 Bottom part of the inner tank system	1
	89012610	MFS31A Bottom part of the inner tank system	1
	89012621	MFS31 Bottom part of the inner tank system	1
	89012622	MFS35 Bottom part of the inner tank system	1
22	01172007	Laterals (115mm) for MFS17	8
	01172008	Laterals (126mm) for MFS20 MFS24 MFS27A MFS31A	8
	01172010	Laterals (185mm) for MFS27 MFS31 MFS35	4
	01172007	Laterals (115mm) for MFS27 MFS31 MFS35	4
23	89012516	Laterals bracket for MFS27 MFS31 MFS35	4
24	89011601	Water Drain Set	1
25	01111059	Filter Base for MFS17 MFS20	1
	01111062	Filter Base for MFS24 MFS27A MFS27	1
	01331003	Filter Base for MFS31A MFS31 MFS35	1

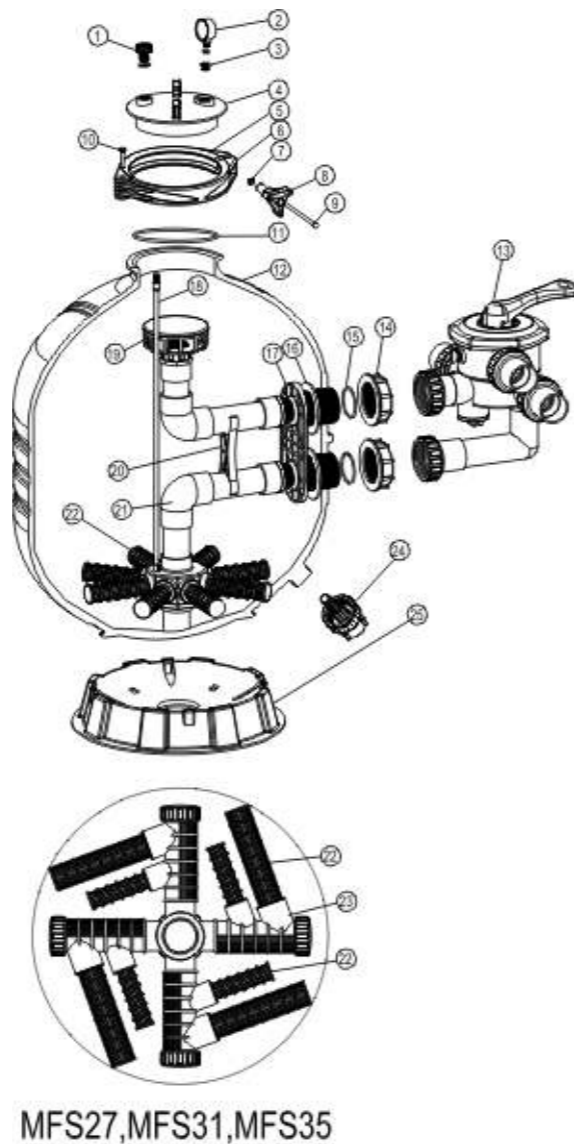

MFS27, MFS31, MFS35

## SPECIFICATIONS

MODEL NO.	MFS17	MFS20	MFS24	MFS27A	MFS27	MFS31A	MFS31	MFS35
CODE	88012626	88012627	88012628	88012629	88012630	88012631	88012632	88012633
Effective Filtration Area (Sq Ft)	0.14	0.20	0.28	0.36	0.39	0.47	0.47	0.61
Filter Max Rate (LPM)	125	175	238	325	325	373	373	515
Filter Max Rate (m <sup>3</sup> /h)	7.5	10.5	14.3	19.5	20.3	22.4	24.7	30.9
Turnover Capacity (In Gallons) - 8 Hour	15840	22176	30202	41184	42874	47309	52166	65261
Turnover Capacity (In Gallons) - 10 Hour	19800	27720	33752	51480	53592	59136	65208	81576
Turnover Capacity (In Gallons) - 12 Hour	23760	33264	45302	61776	64310	70963	78250	97871
All Sand Required (kg)	40	70	125	185	185	320	320	430
A(mm)	670	760	825	946	946	968	968	1086
B(mm)	425	500	600	675	675	775	775	875
C(mm)	125	125	125	125	220	125	220	220
D(mm)	195	225	280	300	300	370	370	440
E(mm)	354.5	396.3	429.5	480.0	527.5	505.5	553.0	609.0
F(mm)	417.5	549.3	492.5	543.0	590.5	568.5	609.0	695.0

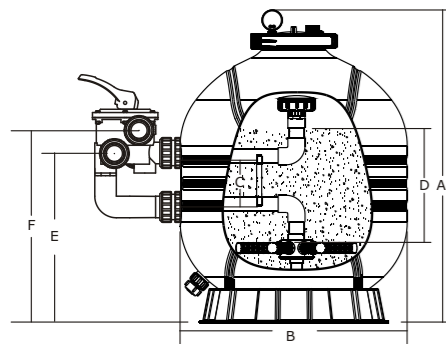

**Emaux Swimming Pool Equipment Co., Ltd**  
 LongZhuIndustrialPark, NanLangIndustrialArea, NanLangTown, ZhongShanCity,  
 Guang Dong, China



## FILTER MAX SERIES SIDE MOUNT FILTER

MODEL: MFS17(88012626), MFS20(88012627), MFS24(88012628),  
 MFS27A(88012629), MFS27(88012630), MFS31A(88012631),  
 MFS31(88012632), MFS35(88012633)

Your Emaux "Filter Max" Filter is a high performance corrosion-proof filter that has superior flow characteristics that is with the ease of operation. Everything is made simple from installation, operation to the maintenance of the filter. Your "Filter Max" filter will be your pool filtration partner that provides clear water with the least maintenance hassle and care.

**WARNING** BEFORE INSTALLATION BE SURE TO READ ALL INSTRUCTIONS AND WARNINGS CAREFULLY. KEEP THIS USER MANUAL FOR FUTURE REFERENCE.

### HOW IT WORKS

The Filter uses special sand to remove dirt particles from pool water. Filter sand is loaded into the filter tank to act as the filtration media. The pool water which contains dirt particles is pumped through your piping system to the filter via the filter control valve. As pool water passes through the filter, dirt particles will be caught by the sand bed and filtered out. The cleaned pool water is returned from the bottom of the Filter Tank, through the control valve and back to the pool through your piping system. The entire sequence is continuous and automatic. It is this sequence that provides the filtration process and circulation of water in your pool.

With the filtration process, dirt will accumulate and becomes saturated in the filter tank. Pressure in the tank will increase and the resistance of water flow will occur. This means it is time to clean (backwash) your filter. Another indication to know when to clean (backwash) the filter is by checking the pressure gauge reading. Backwash operation should be performed when the pressure increases by 10psi above the pressure when it was clean. Typically a clean filter will run at 10 to 15psi depending, so take note of the clean reading when the filter was installed. When the pressure reaches approximately 20 to 25psi or 50% increase from the clean reading proceed to the Backwash operation.

To perform the Backwash operation position the handle on the control valve to "Backwash", the water flow is automatically reversed through the filter so the water is directed from the bottom of the tank, up

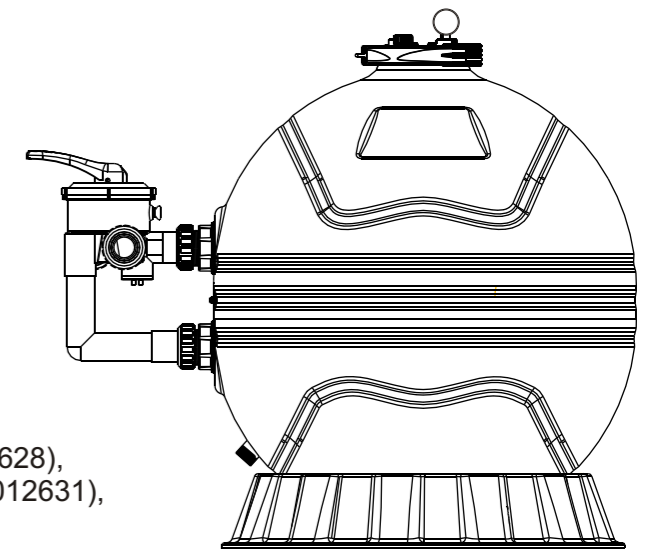

through the sand, flushing the trapped dirt and debris out of the waste line. The duration of the backwash operation will depends on how dirty your filter is. Check the sight glass to see when the water becomes clear. It is recommended that the backwash should be at least 2 minutes long.

Once the backwash operation had been completed, the filter should go through the process of "Rinse" and then back to "Filter". To do perform the different operations, position the handle on the control valve as indicated.

### INSTALLATION

Installation had been made simple, the only tools needed is a screwdriver and pipe sealant for plastic.

The filter should be installed as close to the pool as possible, but keep a distance of at least 5 feet (1.5m). Locate the Filter on hard, level surface, preferably in a dry, shaded, and well-ventilated area. Prior to installation give consideration to the following: Position of suction, return, and waste connections. Access for back-washing operation and servicing; protection from sun, rain, splashing, etc; Drainage of filter room; Ventilation and protection of the motor.

1/ Place the empty tank in position. 2/ Fill the tank with water to the level that covers the laterals about 1/3 of the tank is recommended. This will avoid damages to the laterals by the force of the sand when pouring into the filter.

MFS17 / MFS20 / MFS24 / MFS27A / MFS27 / MFS31A  
 MFS31 / MFS35

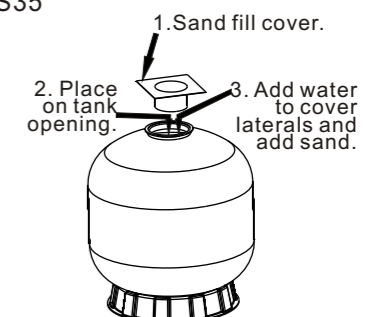

- 3/ Pour the recommended amount of sand into the tank, making sure that the centre-pipe remains centred and vertical.
- 4/ Level the surface of the sand upon completion.
- 5/ Remove the Sand Fill Cover.
- 6/ Carefully remove all sand particles from the valve mounting surface.
- 7/ Place the O-ring into the groove on the tank.
- 8/ Lower the Multiport Control Valve carefully into position so that its underside engages with the centre-pipe. Rotate the valve until the inlet is approximately in line with the pump.
- 9/ Place the clamp set around the tank. Secure using the screw provided.
- 10/ Firmly tap with a rubber mallet outside of the clamps as you tighten the screw.
- 11/ Install the Multiport Control Valve to the filter. Make sure the unions of inlet and outlet are tight.

**FIGURE3.-Clamp Installation**

tap with a rubber mallet and tighten the screws.

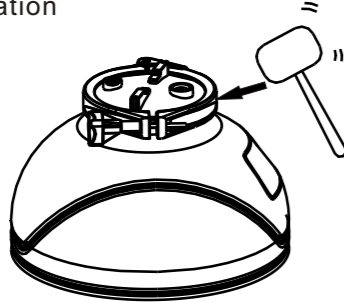

- 12/ Install the pressure gauge into the threaded opening on the Multiport Control Valve.
- 13/ Install the union sets and the backwash union set.
- 14/ Connect pump to the control valve opening marked "PUMP".
- 15/ Make return to pool pipe connection to control valve opening marked "RETURN".
- 16/ Connect the waste water pipe to the control valve opening marked "WASTE".

**TYPICAL INSTALLATION**

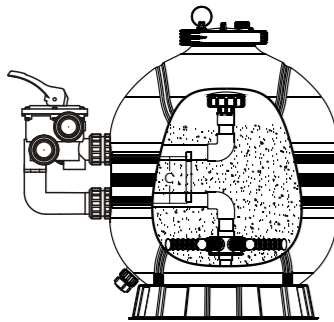

- 17/ To prevent water leakage, be sure all pipe connections are tight.
- 18/ Prior to starting the filtration process by turning on the pump, we highly recommend that you read through the pump instruction manual to ensure proper installation and to avoid the risk of electric shock.

**START-UP PROCEDURE**

- 1/ Be sure the correct amount of filter sand media is in the tank and all connections have been made and are secure.
- 2/ Turn the Control Valve handle to the "Backwash" position. Press the handle downward before turning.
- 3/ Start the pump according to pump instruction manual (be sure all suction and return lines are open).
- 4/ Once water flow is steady out the waste line, run the pump for at least 2 minutes. The initial backwashing of the filter is recommended to remove any impurities or fine sand particles in the sand media.
- 5/ Turn the pump off and set the control valve to RINSE position. Start pump and operate until water in sight glass is clear about 1/2 to 1 minute. Turn pump off, set valve to FILTER position and restart pump. Your filter is now operating in the normal filter mode, filtering particles and dirt from the pool water.
- 6/ Take note of the initial pressure gauge reading for future reference. Variation may occur from pool to pool.
- 7/ Adjust pool suction and return valves to achieve desired flow. Check system and filter for water leaks and tighten connections, bolts, nuts as required.

**NOTE: During the initial clean-up of the pool water, it may be necessary to backwash frequently due to the unusually heavy initial dirt load in the water.**

**IMPORTANT:** To prevent unnecessary strain on piping system and control valve, always turn off the pump before changing the operation of the control valve. To prevent damage to the pump and filter and for proper operation of the system, clean pump strainer (basket) and skimmer basket(s) regularly.

**MULTIPORT CONTROL VALVE FUNCTIONS:-**

- FILTER** gives downward flow through the filter bed. This position can also be used for vacuuming.
- BACKWASH** gives upward flow through the filter bed that removes the dirt from the sand and carries it to the waste.
- WASTE** is for pumping water from the pool. It allows the flow from the pump to bypass the filter and go directly to the waste. You can also use this position to vacuum heavy concentration of debris.
- RECIRCULATE** bypasses the filter to circulate water through the pool system.
- RINSE** gives a downward flow that settles the filter bed after backwashing and carries any remaining loose dirt to the waste.
- CLOSED** prevents only backflow of water from pool during pump maintenance.

To WINTERISE, set the control valve handle in the middle between RINSE and FILTER. This will allow air to leave or enter the tank to help priming and draining. Only to be used when the pump is off.

**VACUUMING THE POOL**

- Light Soil: set the control valve to FILTER position.
- Heavy Soil: set the control valve to WASTE position.

**WINTERRISING**

Backwash the filter for at least thirty minutes before closing down the pool for winterising. This will clean the filter bed thoroughly.

- 1/ Drain the filter tank by removing the drain cap at the base of the filter tank. Leave the cap off during the winter.
- 2/ Set the control valve handle between the RINSE and FILTER. This will lift the handle and help with the draining process by allowing air to enter into the tank.
- 3/ Unscrew the pressure gauge from the control valve and store the gauge indoor.
- 4/ Drain and winterise pump according to pump instructions.
- 5/ Repairs should be made during the off-season when the best service is available do not leave them until the next season.

**TROUBLE SHOOTING**

**SAND BACK TO POOL**

Sand too small; Flow too high; Sand bed calcified; Broken Laterals; Loose centre-pipe; Too much sand; Control Valve not engaged; Air accumulation in filter.

**SAND OUT OF BACKWASH HOSE**

Flow too high; Too much sand in tank.

**INADEQUATE FILTERING**

Dirty make-up water; improper sand; Sand is too low; Algae in filter; Excessive dirt in pool; Calcified sand bed; Heavy swimmer load; Flow rate too high or too low; Backwashing cycle too short; Backwash line too small.

**SHORT FILTER CYCLE**

Dirty filter; Improper sand; Sand is low; Algae in filter; Excessive dirt in pool; Calcified sand bed; heavy swimmer load; Flow rate too high or too low; Backwashing cycle too short; Channels low; Backwash adapter in wrong location; Channels in sand.

**FILTER LEAKS**

Tank cracked; Drain plug not tight; Valve/Tank O'ring damaged.

**CONTROL VALVE LEAKS**

Handle not properly engaged; Valve/Tank O'ring damaged; Valve cover O'ring damaged. Pressure gauge O'ring damaged.

**ABNORMAL LOSS OF POOL WATER**

Leak inside Control Valve; Leakage from pool or piping.

**HIGH PRESSURE FILTER**

Dirty filter; Calcified sand bed; Return lines too small.

**LOW PRESSURE IN FILTER**

Control Valve incorrectly set; Pump running too slow (plugged or clogged); Air leakage into pump suction.

**NOTE:** If the recommendation in this manual do not solve your particular problem(s), please contact your local dealer for service.

**POOL CHEMISTRY GUIDELINES**

SUGGESTED POOL CHEMISTRY LEVELS	ACTION REQUIRED TO CORRECT POOL CHEMISTRY	
	TO RAISE	TO LOWER
pH 7.2 to 7.6	Add Soda Ash	Add Muriatic Acid or Sodium Bisulphate
TOTAL ALKALINITY 100 to 130 ppm	Add Sodium Bicarbonate	Add Muriatic Acid
CHLORINE (UNSTABILIZED) 0.3 to 1.0 ppm	Add Chlorine Chemical	No action-chlorine will naturally dissipate
CHLORINE (STABILIZED) 1.0 to 3.0 ppm	Add Chlorine Chemical	No action-chlorine will naturally dissipate
CHLOR! NE STAB! LIZER 40 to 70 ppm (Cyanuric Acid)	Add Stabilizer	Dilution-partially drain&refill pool with water that has not been treated with Cyanuric Acid.