

1.5" VALVE REPLACEMENT PARTS

Key No.	Part No.	Product Description	Qty
1	01013002	Handle (Small)	1
2	03018008	Pin for Handle	1
3	01181001	Washer for Handle	1
4	89281203	M6×25 Screw with Nut for Camber Lid	6
	89280107	M6×30 Screw with Nut for Standard Lid	6
5	01051010	1.5" Side Mount Valve Standard Lid (White)	1
6	02011022	O-Ring for 1.5" Valve Rotor	2
7	01181002	Washer for Spring	1
8	02011002	O-Ring for 1.5" Valve Lid	1
9	03014001	Spring for 1.5" Side Mount Valve	1
10	01021001	1.5" Valve Rotor	1
11	02311002	Spider Gasket	1
12	01051021	1.5" Side Mount Valve Bottom Body (White)	1
13	01111048	Connector for Pressure Gauge/Stopper	1
	02011139	O-ring	1
14	89021303	Drain Plug with O-ring	1
15	06011032	Oil Pressure Gauge with O-ring (40Psi)	1
16	02020013	O-Ring	5
17	01051022	1.5" Union Tale (White)	1
18	01013017	1.5" Union Nut (Black)	5
19	89280104	Sight Glass with O-Ring	1
20	01051023	1.5" Side Mount Valve Plug (White)	1
21	01051193	1.5" Elbow Tube (White) 120mm	1
22	01171002	1.5" Union Adaptor (Metric)	1
23	01051013	1.5" Connector with External Thread(White)	3
24	02011003	O-Ring $\phi 59 \times \phi 53 \times \phi 3$	5
25	01171153	1.5" Union Adaptor	3

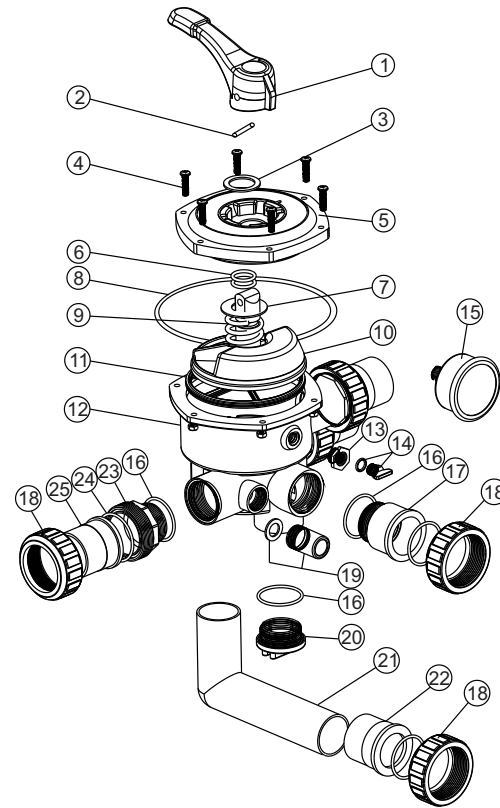

Valve Position	Function
FILTER	Normal Filtration and Vacuuming
BACKWASH	Cleaning Filter by reversing the flow
RINSE	Used after backwash to flush dirt from valve
WASTE	By-passes filter, used for vacuuming to waste or lowering water level
RECIRCULATE	By-passes filter for circulating water to pool
CLOSED	Shuts off all flow to filter or pool

WARNING

- ⚠ THIS FILTER OPERATES UNDER HIGH PRESSURE. WHEN ANY PART OF THE CIRCULATING SYSTEM (e.g., CLAMP, PUMP, FILTER, VALVES, ETC.) IS SERVICED, AIR CAN ENTER THE SYSTEM AND BECOME PRESSURIZED. PRESSURIZED AIR CAN CAUSE THE LID OR VALVE TO BE BLOWN OFF WHICH CAN RESULT IN SEVERE INJURY, DEATH, OR PROPERTY DAMAGE
- ⚠ TURN PUMP OFF BEFORE CHANGING VALVE POSITION.
- ⚠ TO PREVENT DAMAGE TO THE PUMP AND FOR PROPER OPERATION OF THE SYSTEM, CLEAN PUMP STRAINER AND SKIMMER BASKETS REGULARLY.
- ⚠ DO NOT UNSCREW SCREWS OF FLANGE CLAMP WHILE PUMP IS RUNNING.

FSB500-6W, FSB650-6W

FILTER & PUMP COMBO

Installation & Operating Instruction



INSTALLATION

- * Install filtration system including pump, filter tank and multiport valve.
- * The filter system should be installed as close as possible to the swimming pool and preferably at a level of 0.50 metres below the surface of the water in the swimming pool. Make sure there is drainage available at the place where the filter is to be installed.
- * PUMP
 1. Only qualified, licensed personnel should install pump and wiring.
 2. Electrical Contractors Please Note: All 220 volt 50Hz pump must be wired to the main power supply through an approved and correctly rated contractor.
 3. Allow for gate valve in suction piping.
 4. Pump suction and discharge connections have moulded in thread stops, do not try to screw pipe in beyond these stops.
- * FILTER TANK and MULTIPORT VALVE
 1. Loading the sand media. Filter sand media is loaded through the top opening of the filter.
 - a. Loosen the plastic clamps from tank neck.
 - b. Cap internal pipe with plastic cap to prevent sand from entering it.
 - c. We recommend filling tank approximately 1/2 way with water to provide a cushion effect when the filter sand is poured in. This helps protect the under-drain laterals from excessive shock.
 - d. Carefully pour in correct amount and grade of filter sand. Be sure center pipe remains centered in opening. Sand surface should be leveled and should come to about the middle of the filter tank. Remove plastic cap from internal pipe.
 2. Assemble filter control valve to filter tank.
 - a. Insert filter control valve (with O-ring in place) into the tank neck, taking care that the center pipe slips into the hole in the bottom of the valve.
 - b. Place two plastic clamps around valve flange and tank neck and tighten just enough so that the valve may be rotated on tank for final positioning.
 - c. Carefully screw pressure gauge (with O-ring in place) into tapped hole in valve body. Do not over-tighten.
 - d. Connect pump to control valve opening marked PUMP with hose. After connections are made, tighten clamps with screwdriver, tapping around clamp with screwdriver handle to help seat valve flange clamp.
 3. Make return to pool pipe connection to control valve opening marked RETURN and complete other necessary plumbing connections, suction lines to pump, waste, etc.
 4. To prevent water leakage, be sure all pipe connections are tight.

INSTALL/START-UP OF FILTRATION

1. Be sure correct amount of filter media sand is in tank and that all connections have been made and are secure.
2. Depress control valve handle and rotate to BACKWASH position. (To prevent damage to control valve seal, always depress handle before turning.)
3. Prime and start pump. Never run pump dry! Running pump dry may damage seals, causing leakage and flooding! Fill pump with water before starting motor. (be sure all suction and return lines are open), allowing the filter tank to fill with water. Once water is flowing out of the waste line, run the pump for at least 1 minute. The initial back-washing of the filter is recommended to remove any impurities or fine sand particles in the sand media.
4. Turn pump off and set valve to RINSE position. Start pump and operate until water in sight glass is clear, about 1/2 to 1 minute. Turn pump off and set valve to FILTER position and restart pump. The filter is now operating in the normal filter mode, filtering dirt particles from the pool water.
5. Adjust pool suction and return valves to achieve desired flow. Check system and filter for water leaks and tighten connections, bolts, nuts, as required.
6. Note the initial pressure gauge reading when the filter is clean. (It will vary from pool to pool depending upon the pump and general piping system.) As the filter removes dirt and impurities from the pool water, the accumulation in the filter will cause the pressure to rise and flow to diminish. When the pressure gauge reading is 1.5 bar, higher than the initial "clean" pressure you noted, it is time to backwash the filter (see BACKWASH under filter and control valve functions).

NOTE: During initial clean-up of the pool water it may be necessary to backwash frequently due to the unusually heavy initial dirt load in the water.

REPLACEMENT PARTS OF FILTER

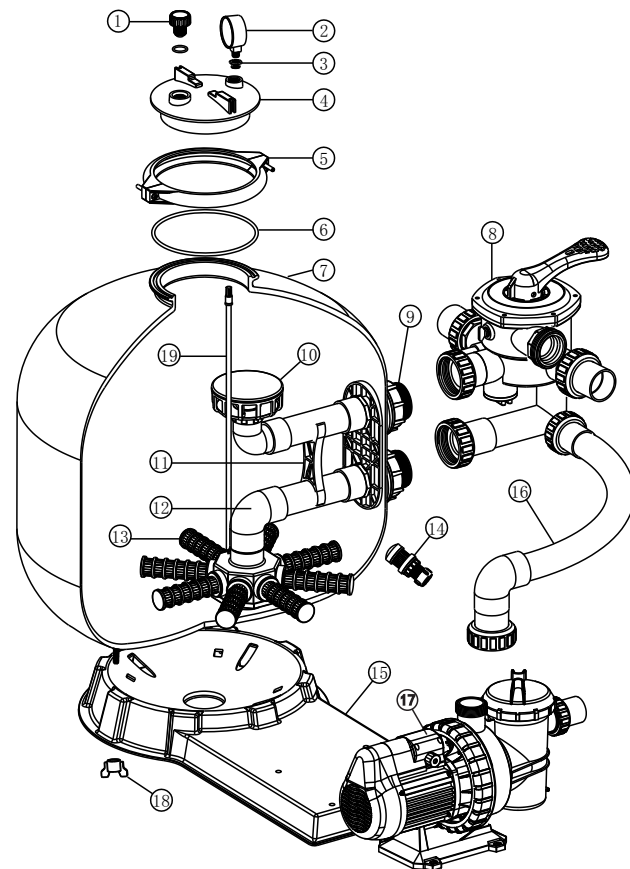

Key NO.	Part NO.	Product Description	QTY
1	89010701	Air Release Valve	1
2	06011032	Oil Pressure Gauge With O-Ring (40psi)	1
3	01111048	Connector for Pressure Gauge/Stopper	1
4	01201022	Lid (Transparent)	1
5	89010119	M6*50 Screws With Nut	2
	01271010	Clamp Lock	2
6	02011134	O-Ring for Filter Neck	1
	89010706	S450 Filter tank	1
7	89010705	S500 Filter tank	1
	89010704	S650 Filter tank	1
8	88280805	1.5" Side Mount Valve	1
9	89010707	Connector Plate Side Mount	1
	89010708	S450 Top part of the inner tank system	1
10	89010709	S500 Top part of the inner tank system	1
	89010710	S650 Top part of the inner tank system	1
11	01111046	Tank System Support	1
	89010712	S450 bottom part of the inner tank system	1
12	89010713	S500 bottom part of the inner tank system	1
	89010714	S650 bottom part of the inner tank system	1
13	01172007	S450 Laterals (115mm)	8
	01172008	S500-S650 Laterals (126mm)	8
14	89010107	Water Drain Set	1
15	01111053	Combo Base	1
	89032901	FSB450-6W Plastic Hose with Nut	1
16	89033001	FSB500-6W Plastic Hose with Nut	1
	89033101	FSB650-6W Plastic Hose with Nut	1
	08030009	FSB450-6W Pump(SS075)	1
17	08030003	FSB500-6W Pump(SC100)	1
	08030004	FSB650-6W Pump(SC150)	1
18	01181052	Fastener for Filter Base	4
	89010716	S450 Air Vent Pipe	1
19	89010717	S500 Air Vent Pipe	1
	89010718	S650 Air Vent Pipe	1

SC PUMP REPLACEMENT PARTS

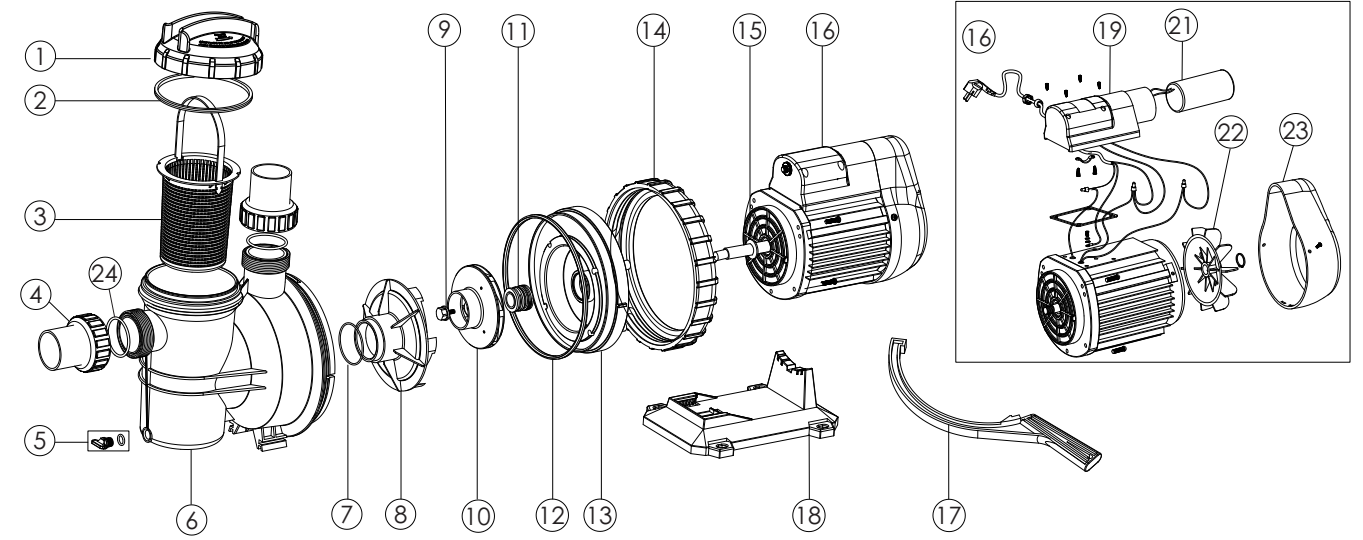

Key NO.	Part Number	Product Description	QTY	Key NO.	Part Number	Product Description	QTY
1	01041043	Transparent Lid	1	15	02011096	Motor Slinger	1
2	02011077	O-Ring for lid	1		89021705	Motor SC050(220V/50HZ)	1
3	01111076	Basket	1		89021706	Motor SC075(220V/50HZ)	1
4	89280105	1.5" union	2	16	89021707	Motor SC100(220V/50HZ)	1
5	89021307	Drain Plug With O-ring	1		89021708	Motor SC150(220V/50HZ)	1
6	01111006	SC Pump Body	1		89021709	Motor SC200(220V/50HZ)	1
7	02011105	O-ring for Diffuser	1	17	01021022	Opening Key	1
8	01111009	Diffuser	1	18	01111007	SC Pumps Base	1
9	89021309	Impeller Screw with O-ring	1	19	89021311	Cable Box for SC Pump	1
	01311009	Impeller SC050(220V/50HZ)	1	20	89021505	Cable Box for SC Pump	1
	01311010	Impeller SC075(220V/50HZ)	1		04016010	Capacitor for SC050 Pump	1
10	01311011	Impeller SC100(220V/50HZ)	1	21	04016012	Capacitor for SC075 Pump	1
	01311012	Impeller SC150(220V/50HZ)	1		04016014	Capacitor for SC100-SC150 Pump	1
	01311013	Impeller SC200(220V/50HZ)	1		04016015	Capacitor for SC200 Pump	1
11	04015032	3/4" Mechanical seal	1	22	01031007	Cooling fan for SC Pump	1
12	02011089	O-ring for Flange	1	23	01031009	Fan Cover	1
13	01111008	SC Pump Flange	1	24	02011104	O-Ring	2
14	01021014	Ring Lock Nut	1				

PRIMING PUMP

- ❖ Release all air from filter and piping system.
- ❖ In a flooded suction system (water source higher than pump), pump will prime itself when suction and discharge valves are opened.
- ❖ If pump is not in a flooded suction system, unscrew and remove trap cover; fill trap and pump with water.
- ❖ Clean and inspect Ring; re-install on trap cover.
- ❖ Replace trap cover on trap; turn clockwise to tighten cover.

NOTICE: Tighten trap cover by hand only .Pump should prime now. Priming time will depend on vertical length of suction lift and horizontal length of suction piping.