

### Parts Diagram and Parts Listing

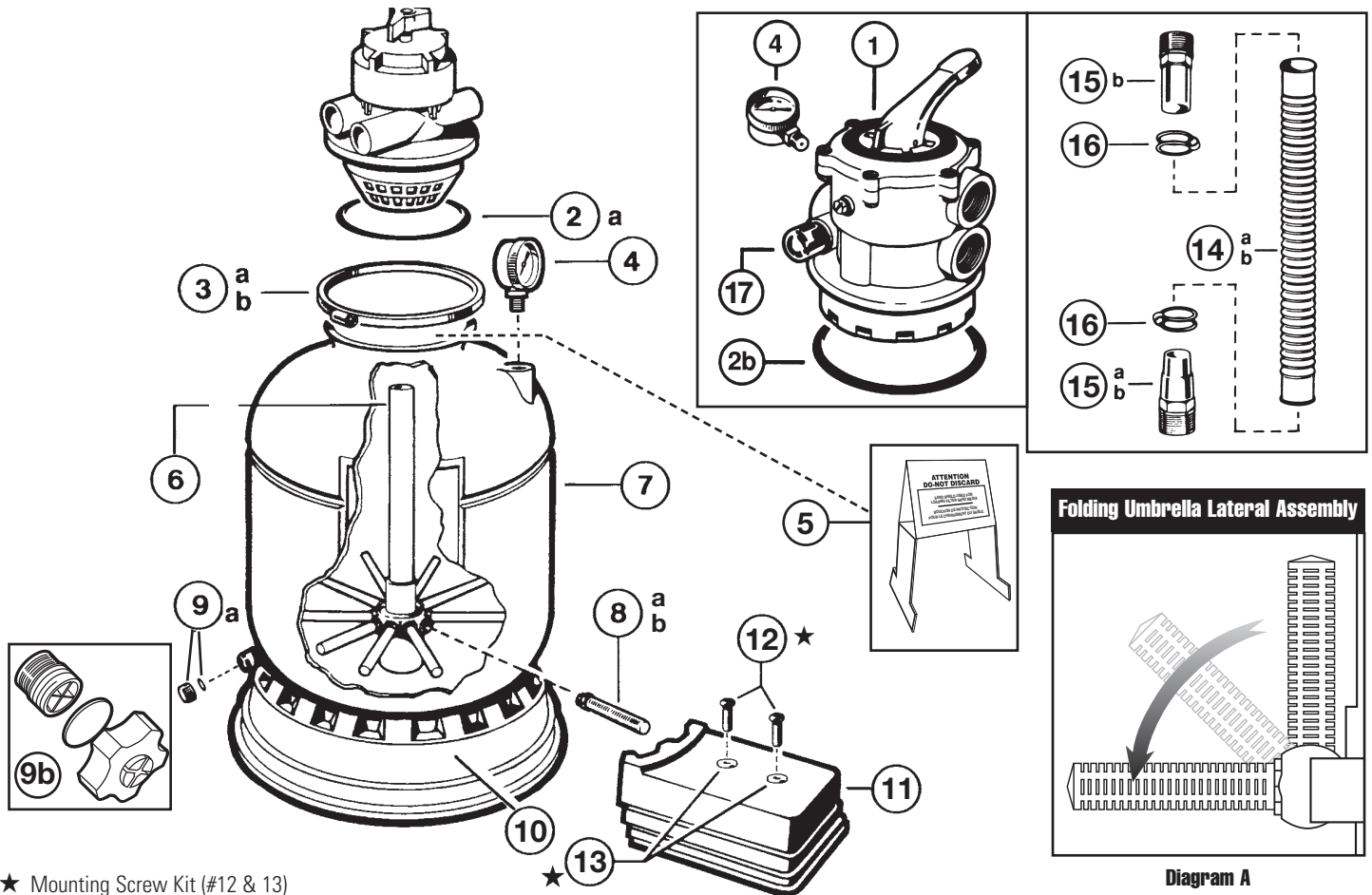

★ Mounting Screw Kit (#12 & 13)

| Ref. No. | Part No.  | Description   | Ctn. Qty. | No. Req'd |
|----------|-----------|---|-----------|-----------|
| 1        | SP0714T*  | Vari-Flo Control Valve 7-position (S144T)                                     | 1         | 1         |
| 2a       | GMX400F   | Valve/Tank O-Ring (S140T)   | 10        | 1         |
| 2b       | GMX600F   | Valve/Tank O-Ring (S144T)   | 10        | 1         |
| 3a       | GMX400K   | Flange Clamp – Valve – Tank (S140T)   | 5         | 1         |
| 3b       | GMX600NM  | Flange Clamp – Valve – Tank (S144T) – Noryl®                                  | 5         | 1         |
| 4        | ECX270861 | Pressure Gauge  | 10        | 1         |
| 5        | SX202S    | Sand Shield – 2004 Corrugated Design  | 25        | 1         |
| 6        | SX144DA   | Folding Umbrella Lateral Assembly with Center Pipe (S144T) (1997- )           | 1         | 1         |
| 7        | SX144AA1  | Filter Tank with Skirt, Lateral Assembly, Drain (S144T)                       | 1         | 1         |
| 8a       | SX200S    | Lateral (2004 and Prior)  | 25        | 10        |
| 8b       | SX200SN   | Lateral (One Piece) with Hub – See Diagram A                                  | 25        | 10        |
| 9a       | SX180HG   | Drain Cap Kit (2005 and Prior)  | 25        | 1         |
| 9b       | SX180LA   | Drain Cap Assembly, Gasket, Screen  | 25        | 1         |
| —        | SX200H    | Bottom Drain Screen (2005 and prior)  | 10        | 1         |
| 10       | SX164B    | Filter Support Stand (Skirt)  | 2         | 1         |
| 11       | SX164C    | Pump Base   | 2         | 1         |
| 12       | ECX1108A  | 5/16" x 3/4" Mounting Screw and 5/16" Washer (2) Kit                          | 10        | 1         |
| 13       | ECX1109   | 5/16" Washer  | 10        | 2         |
| ★        | ECX1108A  | 5/16" x 3/4" Mounting Screws (2) and 5/16" Washers (2) Kit (includes 12 & 13) | 25        | 1         |
| 14a      | GMX142Z15 | 1 1/4" Hose – Ribbed (S140T)  | 5         | 1         |
| 14b      | SX144Z1   | 1 1/2" Hose – Ribbed (S144T)  | 5         | 1         |
| 15a      | SPX1091Z7 | 1 1/2"/1 1/4" Combo Hose Adapter (S140T)                                      | 50        | 1         |
| 15b      | SPX1091Z4 | 1 1/2" Straight Hose Adapter (S144T)  | 25        | 2         |
| 16       | SPX1091Z6 | Hose Clamp  | 10        | 2         |
| 17       | SPX0710MA | Sight Glass for SP0714T Valve   | 10        | 1         |

\*SP0714T Vari-Flo Control Valve used as replacement for GM600 Valve.

**Pro Series sand filters are high performance, totally corrosion-proof filters that blend superior flow characteristics and features with ease of operation. For multiple applications, the Pro Series represents the very latest in sand filter technology and will provide clear, sparkling water for years to come.**

### Applications

- Above-ground/on-ground pools
- Small in-ground pools
- Aquariums (salt or fresh water)
- Ponds

### Features

- Durable, corrosion-proof filter tank molded of color-fast material for long-lasting, all-weather performance
- 7-position Vari-Flo™ valve provides maximum flow at lower pressure drop
- Large pressure sand/water drain for rapid winterizing or servicing
- Flange clamp design allows 360° rotation for easy installation
- Integral top diffuser ensures even distribution of water over the entire sand bed for maximum use of the filtration area
- Precision engineered umbrella-fold self cleaning laterals for balanced flow and backwashing, plus easy serviceability

### Performance Data – Filter

| Model Number | Effective Filtration Area | Design Flow Rate | Turnover (In Gallons) |          |
|--------------|---------------------------|------------------|-----------------------|----------|
|              |                           |                  | 8 Hours               | 10 Hours |
| S144T        | 1.07 ft. <sup>2</sup>     | 25 GPM           | 12,000                | 15,000   |
| S166T        | 1.40 ft. <sup>2</sup>     | 30 GPM           | 14,400                | 18,000   |
| S180T        | 1.75 ft. <sup>2</sup>     | 35 GPM           | 16,800                | 21,000   |
| S210T        | 2.20 ft. <sup>2</sup>     | 44 GPM           | 21,120                | 26,400   |

### Performance Data – Valve Positions

| Model Number | Filter | Back-wash | Waste | Recirc-ulate | Rinse | Closed | Winter |
|--------------|--------|-----------|-------|--------------|-------|--------|--------|
| SP0714T      | •      | •         | •     | •            | •     | •      | •      |



**S166T Pro Series 16" Filter with Vari-Flo Control Valve**



**S180T Pro Series 18" Filter with Vari-Flo Control Valve**

### Pro Series Filter Buying Guide

| Model Number | Filter Control Valve | Filter Base | Hose Pkg.* | Sand Required | Dimensions Width | Dimensions Height | Ctn. Qty. | Ctn. Weight |
|--------------|----------------------|-------------|------------|---------------|------------------|-------------------|-----------|-------------|
| S144T        | SP0714T              | •           | —          | 50 lbs.       | 14 ½"            | 32"               | 1         | 23 lbs.     |
| S144TPAKS    | SP0714T              | •           | 1 ½"       | 50 lbs.       | 14 ½"            | 32"               | 1         | 24 lbs.     |
| S166T        | SP0714T              | •           | —          | 100 lbs.      | 16 ½"            | 33"               | 1         | 25 lbs.     |
| S166TPAKS    | SP0714T              | •           | 1 ½"       | 100 lbs.      | 16 ½"            | 33"               | 1         | 27 lbs.     |
| S180T        | SP0714T              | •           | —          | 150 lbs.      | 18 ½"            | 35"               | 1         | 32 lbs.     |
| S180TPAKS    | SP0714T              | •           | 1 ½"       | 150 lbs.      | 18 ½"            | 35"               | 1         | 32 lbs.     |
| S210T        | SP0714T              | •           | —          | 200 lbs.      | 20 ½"            | 38"               | 1         | 37 lbs.     |

**NOTE:** All above filters except S180T and S210T include snap-on molded pump base.  
\*Hose packages include two six foot hoses and all adapters and clamps necessary for simple installation.

### Buying Tip – The Value of “Paks”

Take advantage of Hayward Filter Paks (each “PAK” includes fully assembled filter, pump base, pump-to-filter hardware and a hose package). The variety of Hayward above ground pumps (see pages 19-20) provides the flexibility to stock one filter and two or three pumps, thus, minimizing your inventory exposure yet still maintaining versatility for merchandising on the retail floor.

Clip Art

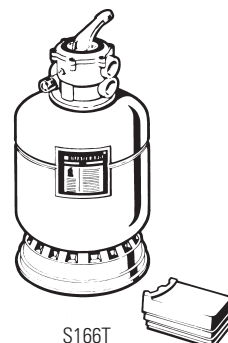

S166T



S180T



# Pro™ & VL™ Series

TOP-MOUNT SAND FILTERS SYSTEMS

Filters



VL Series System



S210T93S Pro Series System

## Pro and VL Series Filter System Buying Guide

| Model Number      | Filter Control Valve | Pump              | H.P.       | System Components | Ctn. Qty. | Ctn. Weight |
|-------------------|----------------------|-------------------|------------|-------------------|-----------|-------------|
| <b>VL Series</b>  |                      |                   |            |                   |           |             |
| VL40T32           | 4 Position           | VL Series Pump    | 30 GPM     | 5                 | 1         | 29 lbs.     |
| <b>Pro Series</b> |                      |                   |            |                   |           |             |
| S144T1540S        | SP0714T              | Power-Flo         | 40 GPM     | 3                 | 1         | 44 lbs.     |
| S144T1540S        | SP0704T              | Power-Flo         | 40 GPM     | 3                 | 1         | 44 lbs.     |
| S166T1580S        | SP0714T              | Power-Flo LX™     | 1          | 3,4               | 1         | 52 lbs.     |
| S166T92S          | SP0714T              | Power-Flo Matrix® | 1          | 2,3,4             | 1         | 52 lbs.     |
| S166T92STL        | SP0714T              | Power-Flo Matrix  | 1          | 1,2,3,4           | 1         | 52 lbs.     |
| S180T1580S        | SP0714T              | Power-Flo LX      | 1          | 3,4               | 1         | 62 lbs.     |
| S180T1580X15S     | SP0714T              | Power-Flo LX      | 1 ½        | 3,4               | 1         | 66 lbs.     |
| S180T92STL        | SP0714T              | Power-Flo Matrix  | 1          | 1,2,3,4           | 1         | 65 lbs.     |
| S180T93S          | SP0714T              | Power-Flo Matrix  | 1 ½        | 2,3,4             | 1         | 66 lbs.     |
| S180T93STL        | SP0714T              | Power-Flo Matrix  | 1 ½        | 1,2,3,4           | 1         | 66 lbs.     |
| S180T932S         | SP0714T              | Power-Flo Matrix  | 1 ½ /2 SPD | 2,3,4             | 1         | 66 lbs.     |
| S210T93S          | SP0714T              | Power-Flo Matrix  | 1 ½        | 2,3,4             | 1         | 67 lbs.     |
| S210T932S         | SP0714T              | Power-Flo Matrix  | 1 ½ /2 SPD | 2,3,4             | 1         | 67 lbs.     |
| S210T93STL        | SP0714T              | Power-Flo Matrix  | 1 ½        | 1,2,3,4           | 1         | 67 lbs.     |
| S230T93S          | SP0714T              | Power-Flo Matrix  | 1 ½        | 2,3,4             | 1         | 67 lbs.     |
| S230T932S         | SP0714T              | Power-Flo Matrix  | 1 ½ /2 SPD | 2,3,4             | 1         | 80 lbs.     |

### System Components

- 3' twist lock cord
- Power-Flo Matrix pump
- 1 ½" hose packages include: two (2) 1 ½" x 6' lengths of hose, hose adapters and hose clamps
- Deluxe one piece base accepts automatic chlorine feeders (CL110ABG/CL220ABG)
- Includes hose adapters

### Optional Accessories

| Model Number | Description  | Ctn. Qty. | Ctn. Weight |
|--------------|--|-----------|-------------|
| SP1500UNPAK2 | Set of two (2) quick connect unions  | 50        | 32 lbs.     |
| EC1155       | 1 ½" Suction and Discharge Hose Package. Includes: two (2) each 1 ½" x 6' hoses; 1 ½" hose adapters and 1 ½" hose clamps | 1         | 3 ½ lbs.    |
| EC1079SPK24  | 24-piece 1 ½" x 6' Spiral Hose Pack  | 1         | 25 lbs.     |

**Pro Series sand systems are designed and equipped to offer the ideal combination of energy efficiency and outstanding water clarity. A broad selection of filter sizes, pumps, and accessories allows you to choose and merchandise the system(s) that best suit your above-ground pool program.**

**VL Series above-ground systems offer the performance and reliability expected from the world's leading provider of above ground equipment. Easy to assemble with an integrated pump base, the incredibly quiet pump and proven sand filter technology provide trouble-free operation.**

### System Features

- Systems are designed for quick assembly and precise alignment of components
- Pumps and filters are performance-matched to provide maximum flow and energy efficiency
- Multi-position valve provides maximum flow at low pressure drop
- Filter bases are molded of rugged thermoplastic for long-lasting, all-weather performance

### Optional Microprocessor Timer Features (Pro Series Only)

- Audible beep
- Preset filtration settings
- Manual override
- Retrofits to any Flex48 frame motor
- Order system with 'FT' suffix



Microprocessor Timer



### S180T92S includes:

- 18" Polymeric Tank
- 7-Position Filter Control Valve
- SP1592, 1 H.P. Power-Flo Matrix Pump
- One Piece Deluxe Base
- 1 ½" Hose Package



### S210T93S includes:

- 20" Polymeric Tank
- 7-Position Filter Control Valve
- SP1593, 1 1/2 H.P. Power-Flo Matrix Pump
- One Piece Deluxe Base
- 1 ½" Hose Package

### S230T93S includes:

- 23" Polymeric Tank
- Same as S210T93S (see above)



**HAYWARD**