

VALVE REPLACEMENT PARTS

Key No.	Part No.	Description	Qty
1	01013130	Handle	1
2	03018160	Pin for Handle	1
3	01013131	Fixation for 1.5" 4-Way Valve Handle	1
4	03011003	¢ 4 x 12 Self-Drilling Screw	3
5	01013132	Pressing Ring	1
6	01181060	Washer for 1.5" 4-Way Valve Handle	1
7	02011095	O-Ring for Rotor	2
8	06021014	Plastic Pressure Gauge with O-Ring (28Psi)	1
9	01013134	Body	1
10	89280104	Sight Glass with O-Ring	1
11	89281601	1.5" 4-way Valve Rotor Assembly	1 </td
12	02311010	Spider Gasket	1
13	02011184	O-Ring for Diffuser	1

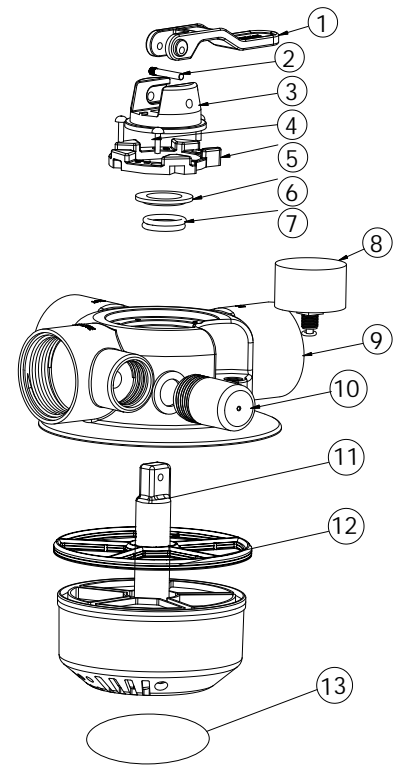

Valve Position	Function
FILTER	Normal Filtration and Vacuuming
BACKWASH	Cleaning Filter by reversing the flow
RINSE	Used after backwash to flush dirt from valve
CLOSED	Shuts off all flow to filter or pool

WARNING

- ⚠ THIS FILTER OPERATES UNDER HIGH PRESSURE. WHEN ANY PART OF THE CIRCULATING SYSTEM (e.g., CLAMP, PUMP, FILTER, VALVES, ETC.) IS SERVICED, AIR CAN ENTER THE SYSTEM AND BECOME PRESSURIZED. PRESSURIZED AIR CAN CAUSE THE LID OR VALVE TO BE BLOWN OFF WHICH CAN RESULT IN SEVERE INJURY, DEATH, OR PROPERTY DAMAGE
- ⚠ TURN PUMP OFF BEFORE CHANGING VALVE POSITION.
- ⚠ TO PREVENT DAMAGE TO THE PUMP AND FOR PROPER OPERATION OF THE SYSTEM, CLEAN PUMP STRAINER AND SKIMMER BASKETS REGULARLY.
- ⚠ DO NOT UNSCREW SCREWS OF FLANGE CLAMP WHILE PUMP IS RUNNING.