

# FILTER & PUMP COMBO

FSP300-4W

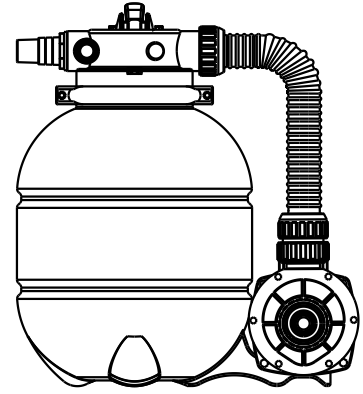

## INSTALLATION

\* Install filtration system including pump, filter tank and multiport valve.

\* The filter system should be installed as close as possible to the swimming pool and preferably at a level of 0.50 metres below the surface of the water in the swimming pool. Make sure there is drainage available at the place where the filter is to be installed.

\* PUMP

1. Only qualified, licensed personnel should install pump and wiring.
2. Electrical Contractors Please Note: All 220V/60Hz pump must be wired to the main power supply through an approved and correctly rated contractor.
3. Allow for gate valve in suction piping.
4. Pump suction and discharge connections have moulded in thread stops, do not try to screw pipe in beyond these stops.

\* FILTER TANK and MULTI-PORT VALVE

1. Loading the sand media. Filter sand media is loaded through the top opening of the filter.
  - A. Loosen the plastic clamps from tank neck.
  - b. Cap internal pipe with plastic cap to prevent sand from entering it.
  - c. We recommend filling tank approximately 1/2 way with water to provide a cushion effect when the filter sand is poured in. This helps protect the under-drain laterals from

excessive shock.

d. Carefully pour in correct amount and grade of filter sand. Be sure center pipe remains centered in opening. Sand surface should be leveled and should come to about the middle of the filter tank. Remove plastic cap from internal pipe.

2. Assemble filter control valve to filter tank.

a. Insert filter control valve (with O-ring in place) into the tank neck, taking care that the center pipe slips into the hole in the bottom of the valve.

b. Place two plastic clamps around valve flange and tank neck and tighten just enough so that the valve may be rotated on tank for final positioning.

c. Carefully screw pressure gauge (with O-ring in place) into tapped hole in valve body. Do not over-tighten.

d. Connect pump to control valve opening marked IN with hose. After connections are made, tighten clamps with screwdriver, tapping around clamp with screwdriver handle to help seat valve flange clamp.

3. Make return to pool pipe connection to control valve opening marked OUT and complete other necessary plumbing connections, suction lines to pump, waste, etc.

4. To prevent water leakage, be sure all pipe connections are tight.

## INSTALL/START-UP OF FILTRATION

1. Be sure correct amount of filter media sand is in tank and that all connections have been made and are secure.
2. Depress control valve handle and rotate to BACKWASH position. (To prevent damage to control valve seal, always depress handle before turning.)
3. Prime and start pump. Never run pump dry! Running pump dry may damage seals, causing leakage and flooding! Fill pump with water before starting motor. (be sure all suction and return lines are open), allowing the filter tank to fill with water. Once water is flowing out of the waste line, run the pump for at least 1 minute. The initial back-washing of the filter is recommended to remove any impurities or fine sand particles in the sand media.
4. Turn pump off and set valve to RINSE position. Start pump and operate until water in sight glass is clear, about 1/2 to 1 minute. Turn pump off and set valve to

FILTER position and restart pump. The filter is now operating in the normal filter mode, filtering dirt particles from the pool water.

5. Adjust pool suction and return valves to achieve desired flow. Check system and filter for water leaks and tighten connections, bolts, nuts, as required.

6. Note the initial pressure gauge reading when the filter is clean. (It will vary from pool to pool depending upon the pump and general piping system.) As the filter removes dirt and impurities from the pool water, the accumulation in the filter will cause the pressure to rise and flow to diminish. When the pressure gauge reading is 1.5 bar, higher than the initial "clean" pressure you noted, it is time to backwash the filter (see BACKWASH under filter and control valve functions).

NOTE: During initial clean-up of the pool water it may be necessary to backwash frequently due to the unusually heavy initial dirt load in the water.

## PRIMING PUMP

- ❖ Release all air from filter and piping system.
- ❖ In a flooded suction system (water source higher than pump), pump will prime itself when suction and discharge valves are opened.
- ❖ If pump is not in a flooded suction system, unscrew and remove trap cover; fill trap and pump with water.
- ❖ Clean and inspect Ring; re-install on trap cover.
- ❖ Replace trap cover on trap; turn clockwise to tighten cover.



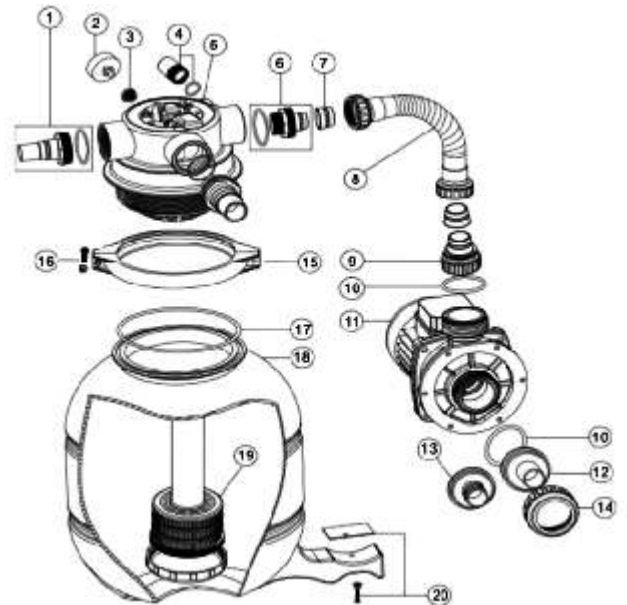

NOTICE: Tighten trap cover by hand only .Pump should prime now. Priming time will depend on vertical length of suction lift and horizontal length of suction piping.

## REPLACEMENT PARTS OF FILTER

Item	Part No.	Description	Qty
1	89030201	32mm & 38mm Adaptor With O-ring	2
2	06021013	Maximum 40PSI Indication, Plastic Casing	1
3	01111048	Connector for Pressure Gauge/Stopper	1
4	89280104	Sight Glass with O-Ring	1
5	88281205B	4 Way 1.5" Top Mount Valve (Valve Only) (Black)	1
6	89030204	Hose Adaptor with O-Ring	1
7	02011026	Sleeve for Hose	2
8	89030202	FSP300-4W Plastic Hose with Nut	1
9	01013049	Hose adaptor with Nut	1
10	02011104	O-Ring for 1.5" Union	2
11	88023017	ST013 Pump	1
11	88023101	Pump 0.20hp, 220V/60Hz, Single Phase	1
11	88023102	Pump 0.33hp, 220V/60Hz, Single Phase	1
12	01013053	32mm Union	1
13	01013045	38mm Union	1
14	01013017	1.5"Union Nut (black)	3
15	01271010	Clamp Lock	2
16	89010119	M6*50 Screws With Nut	2
17	02011134	O-Ring for Filter Neck	1
18	01331001	FSP300 Filter tank	1
19	89030205	FSP300 Lateral Assembly with Center Pipe	1
20	89030203	Pump Assembly Screw	1



## WARNING

-  THIS FILTER OPERATES UNDER HIGH PRESSURE. WHEN ANY PART OF THE CIRCULATING SYSTEM (e.g., CLAMP, PUMP, FILTER, VALVES, ETC.) IS SERVICED, AIR CAN ENTER THE SYSTEM AND BECOME PRESSURIZED . PRESSURIZED AIR CAN CAUSE THE LID OR VALVE TO BE BLOWN OFF WHICH CAN RESULT IN SEVERE INJURY, DEATH, OR PROPERTY DAMAGE
-  TURN PUMP OFF BEFORE CHANGING VALVE POSITION.
-  TO PREVENT DAMAGE TO THE PUMP AND FOR PROPER OPERATION OF THE SYSTEM, CLEAN PUMP STRAINER AND SKIMMER BASKETS REGULARLY.
-  DO NOT UNSCREW SCREWS OF FLANGE CLAMP WHILE PUMP IS RUNNING.