

V - JET

Counteflow System



**V-JET Counterflow System Installation and Operation
Manual**

1. System Installation

By purchasing the V - JET counterflow system you have obtained high-quality product, which will make the moments spent in a swimming pool more pleasant. V-JET is supplied with NEW BCC motors of input power 2.2kW ; 3.0kW and 4.1kW in 230V as well as 400V versions. It implies that you may chose the motor acc. to voltage used at your swimming pool.

The electric pump should be installed as close to the swimming pool as possible to achieve maximum power and prevent losses due to friction. Original diameters of PVC accessories delivered with the system should be followed in any case. Positioning of the pump at a distance exceeding 15 m from the swimming pool is not recommended.

The NEW BCC series pumps forming part of the system are not self-priming, thus they shall be installed under the water level. The system technological space shall be properly vented, even with fan as needed, to prevent water precipitation (condensation). It this way proper operation of the V-JET system is achieved.

2. Fixing of Counterflow Body

On installation of the counterflow body please note that it must be installed in position shown on Fig. 1. Both discharge pipe of diameter 75mm and suction pipe of diameter 90mm shall be positioned in vertical position, as the discharge side (diameter 75mm) must be above the suction side (diameter 90mm), see Fig. 1.

Position the counterflow system in such manner that the nozzle hole centre is ca 30cm below the water level (see Fig. 1).

The instruction are of critical importance and they must be adhered to during the system installation, otherwise proper operation of the counterflow cannot be guaranteed.

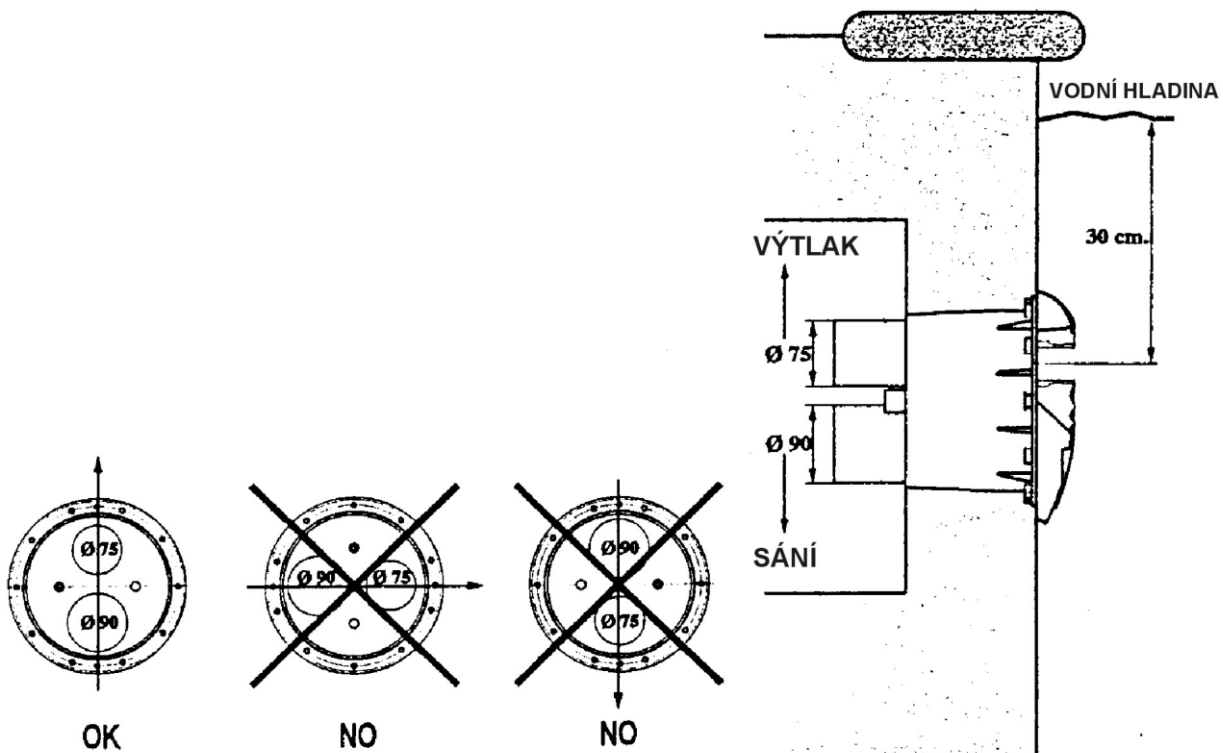

Legend: water level; discharge; suction

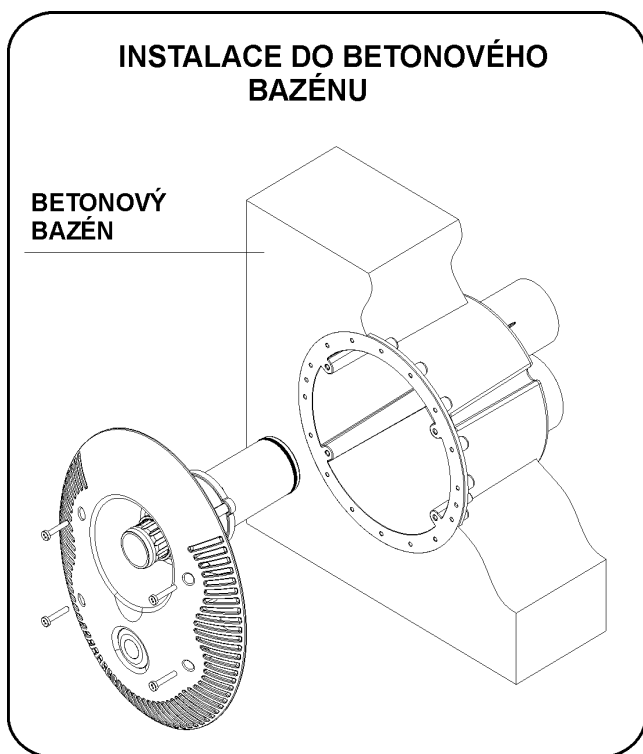

Installation to concrete pool; concrete pool

Fig. 2a

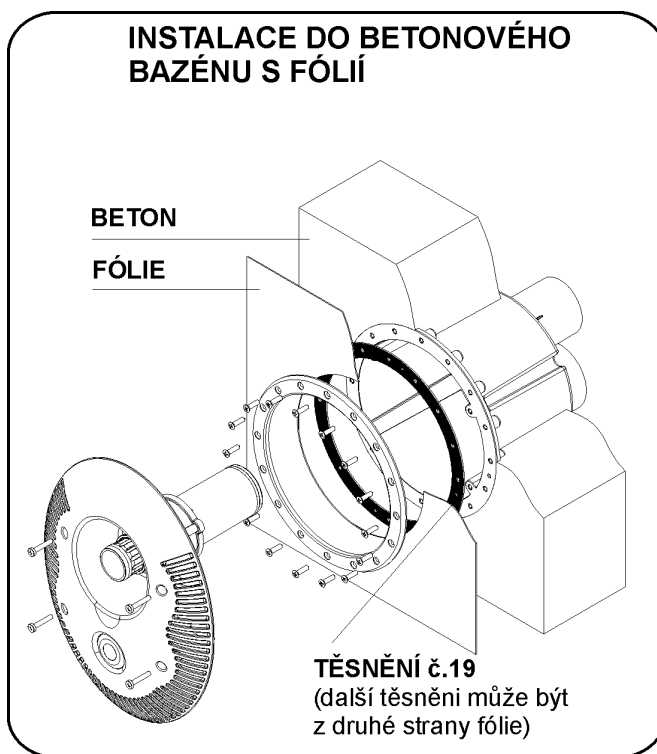

Installation to concrete pool with foil; concrete; foil; seal no. 19 (another seal may be fitted from the foil other side)

Fig. 2b

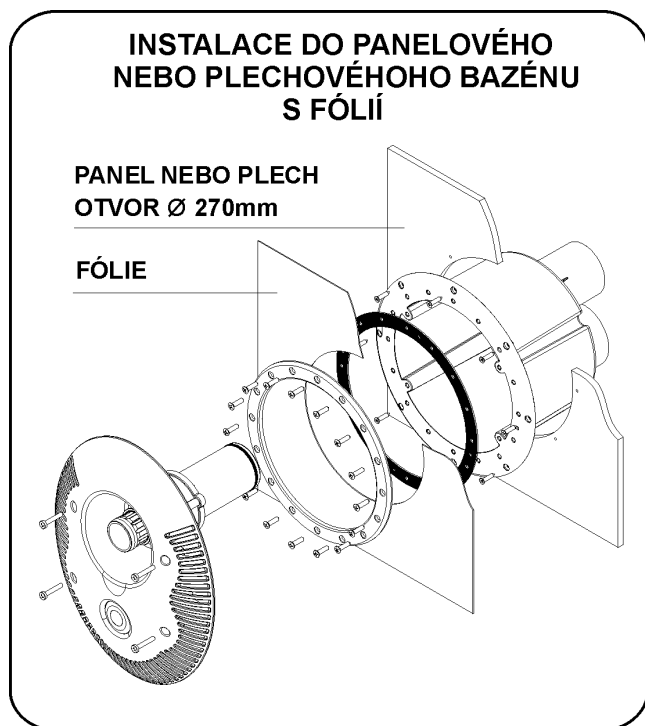

Installation to panel or sheet pool with foil or sheet with hole diam. 270 mm; foil

Fig. 2c

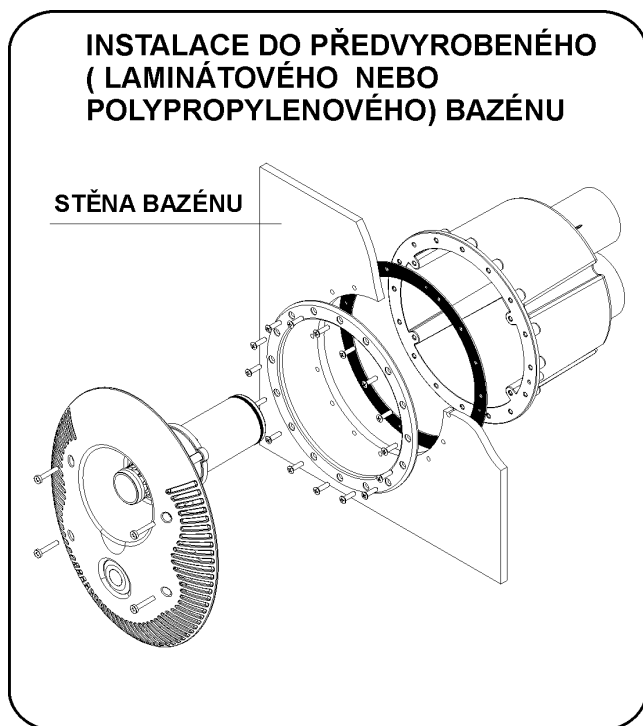

Installation to prefabricated (laminated or polypropylene) pool; pool wall

Fig. 2d

3. Installation of Counterflow Body into Concrete

Stick the hoses (pos. 21 Fig. 3) to the counterflow body (pos. 20 Fig. 3) and pass them into the technological space (well). Protect the hose ends against concrete. Install the counterflow body pos. 20 Fig. 3 acc. to Fig. 2a into the hole in concrete wall or cladding for concreting without flange and seals. As soon as the body is fixed into the wall, follow the instructions specified in section 4 and install pneumatic and air lines.

3.1 Installation of Counterflow Body into Concrete Pools with Foil

Installation of the counterflow body into the concrete pool wall with foil shall comply with instruction specified in section no. 2 and 3 . After fixing of the counterflow body to the pool wall you may install the counterflow seals and flange, Fig. 2b.

Tighten the seals (pos. 18, Fig 3) to the counterflow body (pos. 20, Fig. 3) by means of 2 screws (pos. 19, Fig. 3); please note that the pool foil may be positioned between the two seals (Fig. 2b). Finally install the flange (pos. 17, Fig. 3) and tighten the screws (pos. 16, Fig. 3), only then cut the foil from the flange inner side.

Install the air and pneumatic lines acc. to instructions given in section 4.

3.2 Installation of Counterflow Body to Panel or Sheet Pool with Foil

Prepare a hole of diameter 270mm in the pool wall in such manner that the nozzle centre is ca 30cm below the water level, s describe in section 2 and Fig. 1. Fit the counterflow body pos. 20 Fig. 3 from the pool inner side into the prepared hole. Fix the body into the pool wall as shown on Fig. 2c by means of self-cutting screws pos. 19 Fig. 3.

Tighten seals (pos. 18, Fig. 3) to the counterflow body (pos. 20, Fig. 3) by means of 2 screws (pos. 19, Fig. 3), install foil, then fix the flange (pos. 17, Fig. 3) and tighten the screws (pos. 16, Fig. 3), only then cut the foil from the flange inner side.

Install the air and pneumatic lines acc. to instructions given in section 4.

3.3 Installation of Counterflow Body to Prefabricated (Laminated or Polypropylene) Pool

Cut a hole of diameter 230mm in the pool wall in such manner that the nozzle centre is ca 30cm below the water level, s describe in section 2 and Fig. 1.

Stick the seals (pos. 18, Fig. 3) from the pool wall outer side and prepare holes for 16 screws of the flange (pos. 16, Fig. 3) acc. to this template.

Prepare the counterflow body (pos. 20. Fig. 3) from the pool outer side and fix the flange (pos. 17, Fig. 3) with screws (pos. 16, Fig. 3) from the inner part as shown on Fig. 2d.

Install the air and pneumatic lines acc. to instructions given in section 4.

4. Installation of Air and Pneumatic Lines

Installation of Air Lines:

Stick the reduction piece (pos. 22, Fig. 3) to the hose serving as the air line and install the check valve (pos. 23, Fig. 3). It is important to locate the check valve to the technological space wall to prevent suctioning of dirt (see Fig. 6). Finally fix the flexible tube (pos. 13, Fig. 3) by pressing it into the nozzle inside the counterflow body (see Fig. 4).

Installation of Pneumatic Lines:

This line consists from hose (pos. 21, Fig. 3) serving as protecting sleeve for pneumatic switching hose. Position the pneumatic switching hose into the pneumatic line (hose pos. 21, Fig. 3) and lead its end through the hole in the counterflow body (pos. 20, Fig. 3), tighten it by the penetration sleeve (pos. 14).

The hose end (pos. 2, Fig. 3) shall be connected to the pneumatic switch (pos. 1, Fig. 3) located at the face of the V-JET counterflow system.

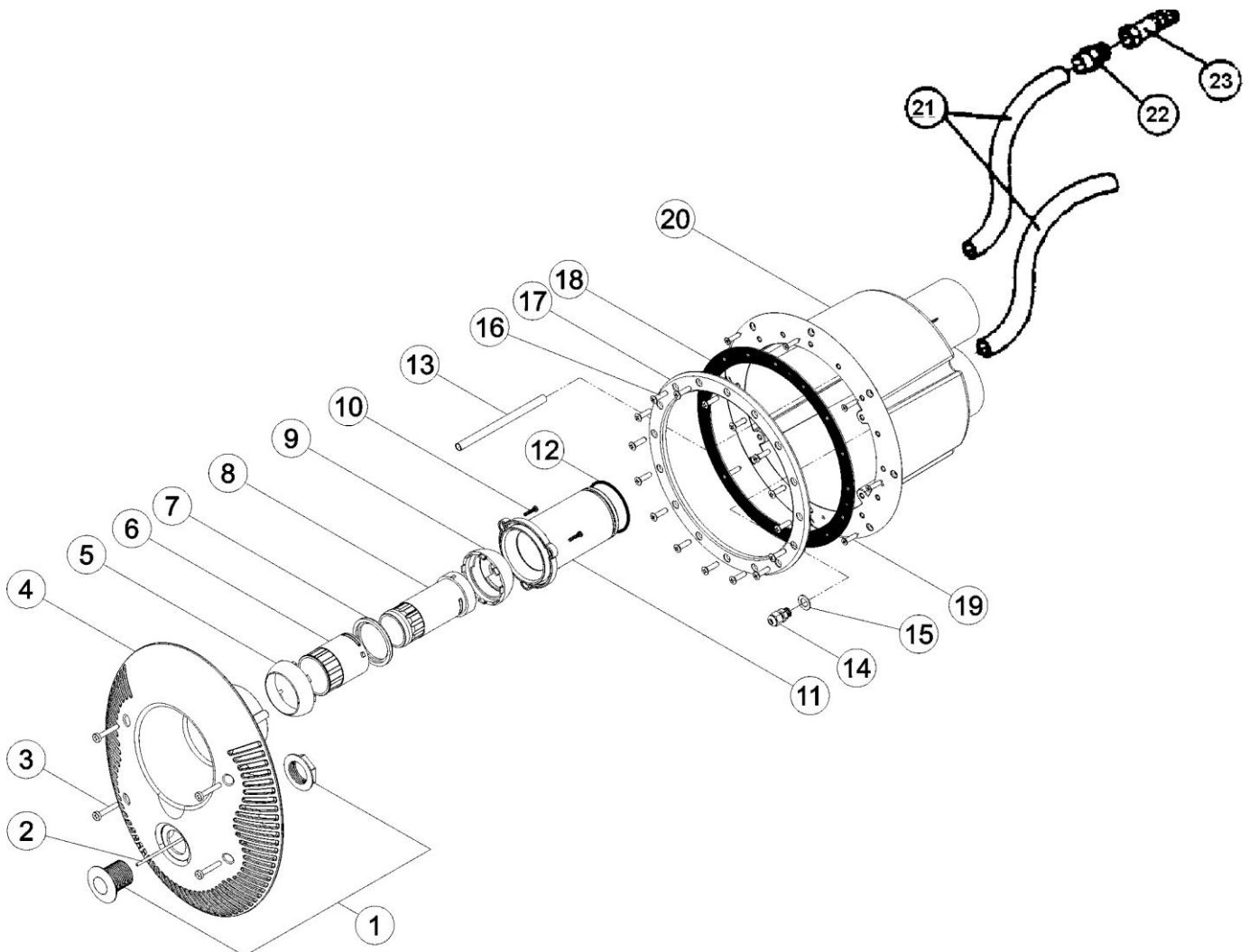

Fig. 3

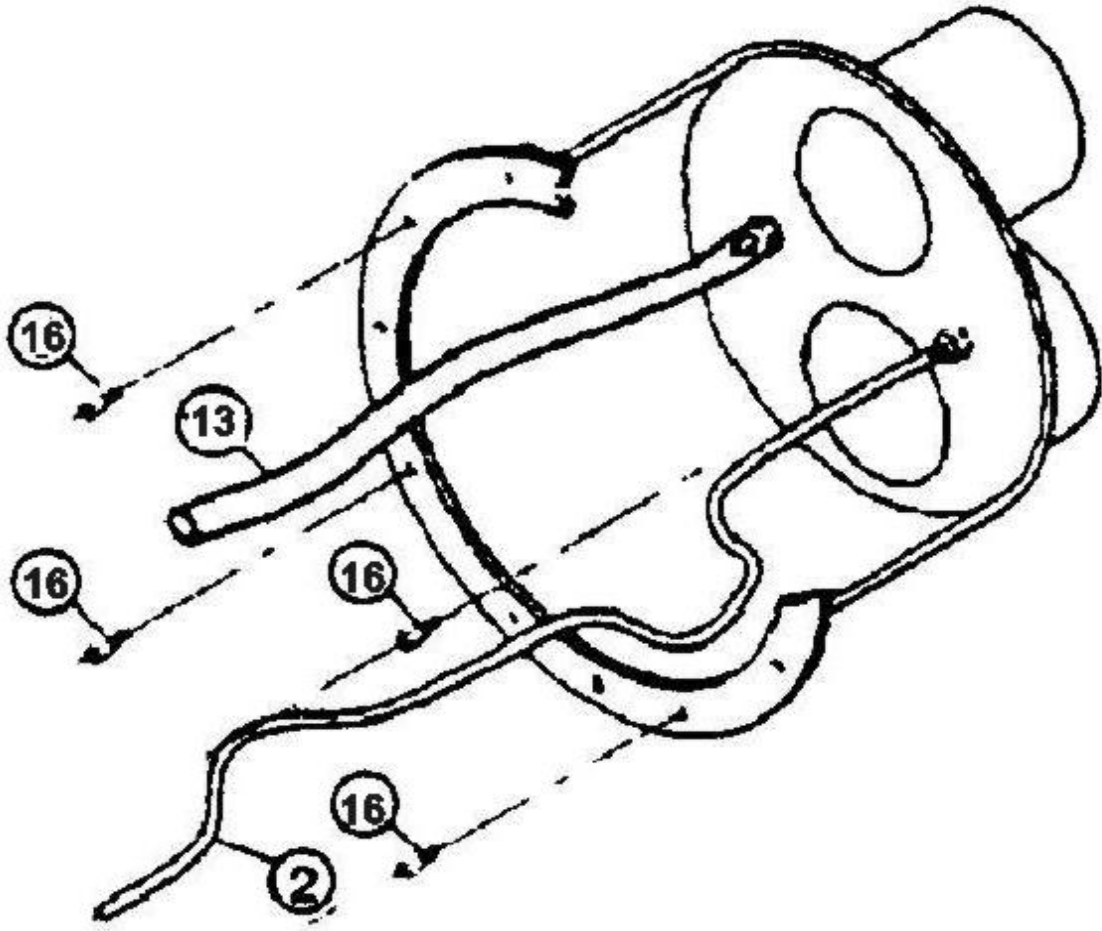

Fig. 4

5. Fixing of Counterflow Face Cover

Complete face cover is supplied in assembled state and includes parts pos. 1 to 12 (see Fig. 3). An exception is transparent pneumatic hose (pos. 2), which yet forms part of the counterflow body (see Fig. 4).

Installation procedure of face cover is as follows:

- Connect hose pos. 2, insert it to the mandrel of pneumatic switch (pos. 1, Fig. 3).
- Connect hose pos. 13, insert it to the nozzle at the face cover.
- Connect the complete face cover with the counterflow body, note that the ring (pos. 12) shall be inserted into neck of the outlet hole (diameter 75mm).
- Tighten four screws (pos. 3, Fig. 3). As soon as they are securely tightened, the face cover is ready to use.

6. PVC Set for Installation of Suction and Discharge Pipes

V-JET includes a PVC set for installation of suction pipe (diameter 75mm) and discharge pipe (diameter 75mm), see table below.

PVC Set		
Pos.	DESCRIPTION	Quantity
1	Reduction piece 90x75mm	1
2	Ball valve - diam. 75mm	2
3	90 grade bend - diam. 75mm	3

Installation of Discharge and Suction Pipe:

Prepare tubes of diameter 75mm acc. to disposition in technological space (well) for counterflow and stick the suction and discharge pipes acc. to Fig. 5

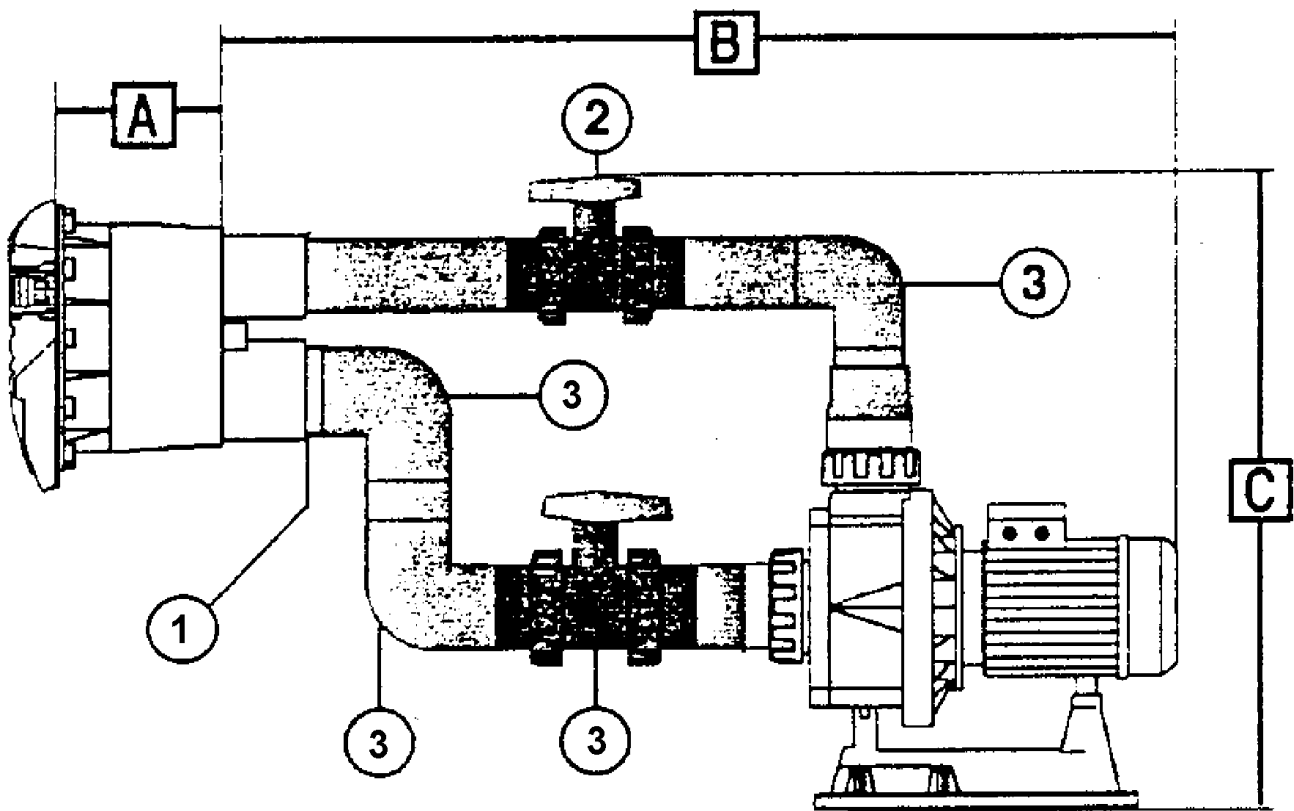

Fig. 5

A	B	C
165mm	1005mm	600mm

7. Minimum Requirement to System Installation Space

Before the V-JET system is installed, please consider dimensions of technological space (well), where the counterflow is to be located. Make use in advance that there will be no spatial problems during the pump installation. Minimum recommended sizes of the technological space needed for installation of the system - see Fig. 6 + table.

Width	Length A	Height B
750	1420	900

Legend: water level; air suction; venting; to electric panel

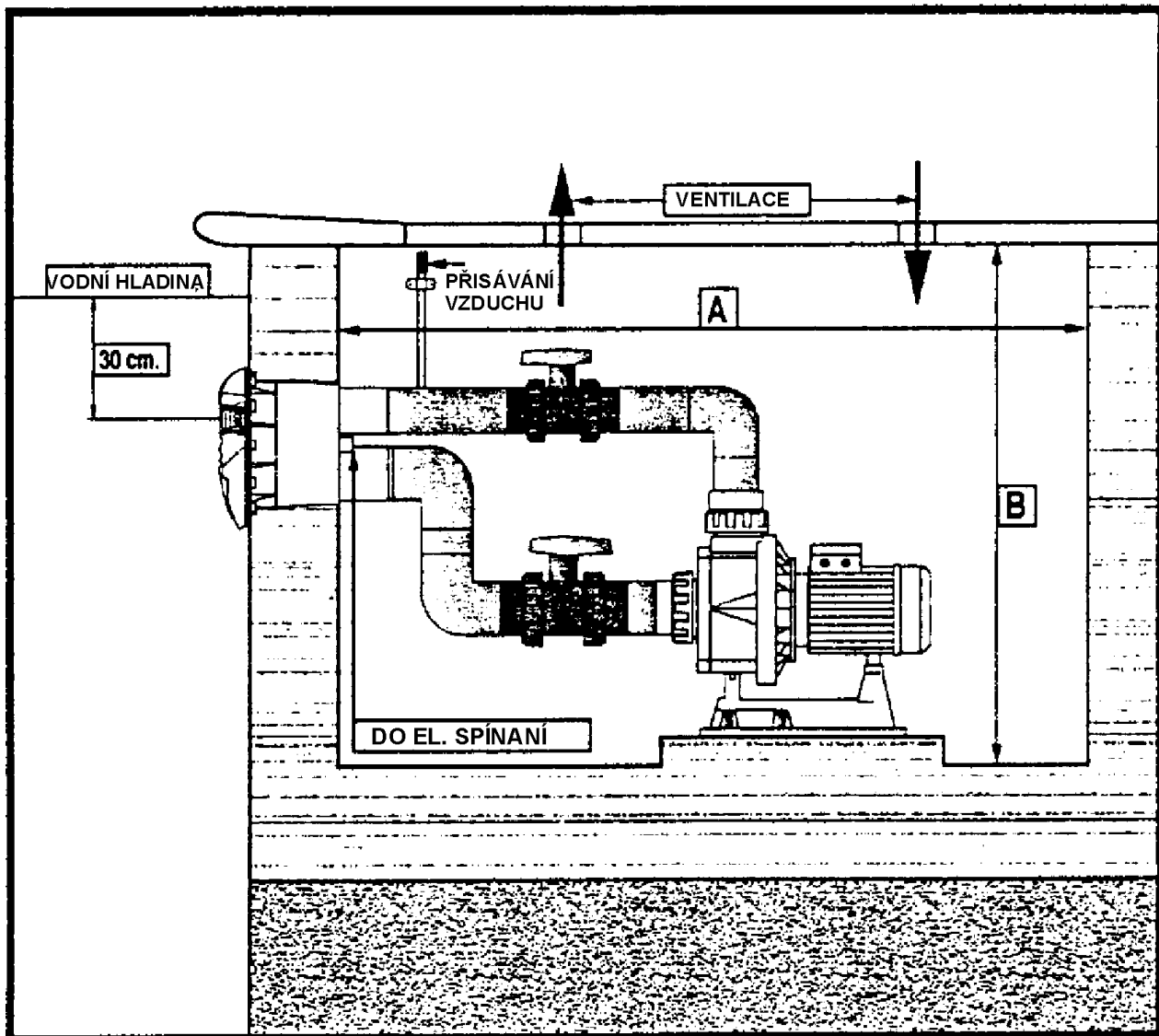

Fig. 6

8. V-JET System Operation and Adjustment

As soon as the V-JET is installed, the swimming pool is place of your rest and fun due to pleasant excitement from the flow of water or aired water generated by the unit.

The counterflow is started from the pool by pressing of pneumatic switch (pos. 1, Fig. 7).

The started counterflow supplies: only water flow, or flow of water with air. It depends on adjustment of front nozzles (see Fig. 7). Only water flow: Maximum water flow is achieved by turning of inner nozzle (pos. 2, Fig. 7) CCW. The water flow is limited by turning the nozzle CW. Flow of water with air: Turn the outer nozzle to adjust/limit the air flow (pos. 3, Fig. 7).

Legend: conterflow nozzle detail; maximum flow; minimum flow

DETAIL PROTIPROUDÉ TRYSKY

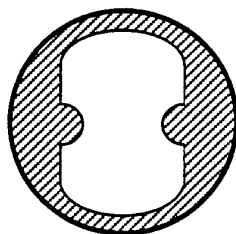

MAXIMÁLNÍ PRŮTOK

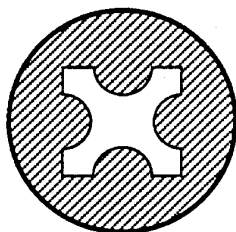

MINIMÁLNÍ PRŮTOK

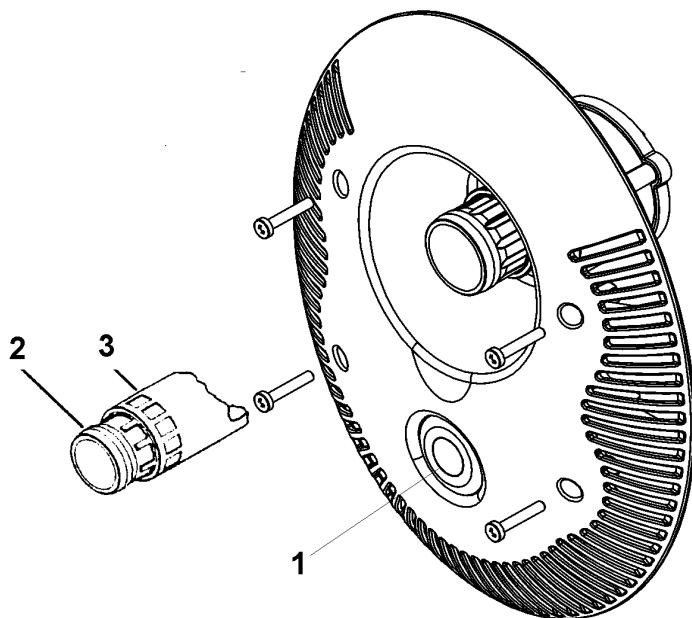

Fig. 7

9. V-JET Counterflow Part List

Pos.	Description	Quantity	Pos.	Description	Quantity
1	Pneumatic switch	1 pc	13	Flexible hose (air)	1 pc
2	Pneumatic hose	7m	14	Pneum. hose penetration sleeve	1 pc
3	Front screw	4 pcs	15	Penetration O-ring	1 pc
4	Counterflow face cover	1 pc	16	Flange screw	16 pcs
5	External ball	1 pc	18	Seals	2 pcs
6	Air flow control nozzle	1 pc	17	Flange	1 pc
7	Support ring	1 pc	19	Counterflow self-cutting screw	4 pcs
8	Water flow control nozzle	1 pc	20	Counterflow body	1 pc
9	Inner ball	1 pc	21	Air and pneumatic line hoses	2x1m
10	Nozzle self-cutting screw	3 pcs	22	Reduction piece 20x 1/2" ex	1 pc
11	Nozzle fitting	1 pc	23	Air suction check valve	1 pc
12	O-ring	1 pc			

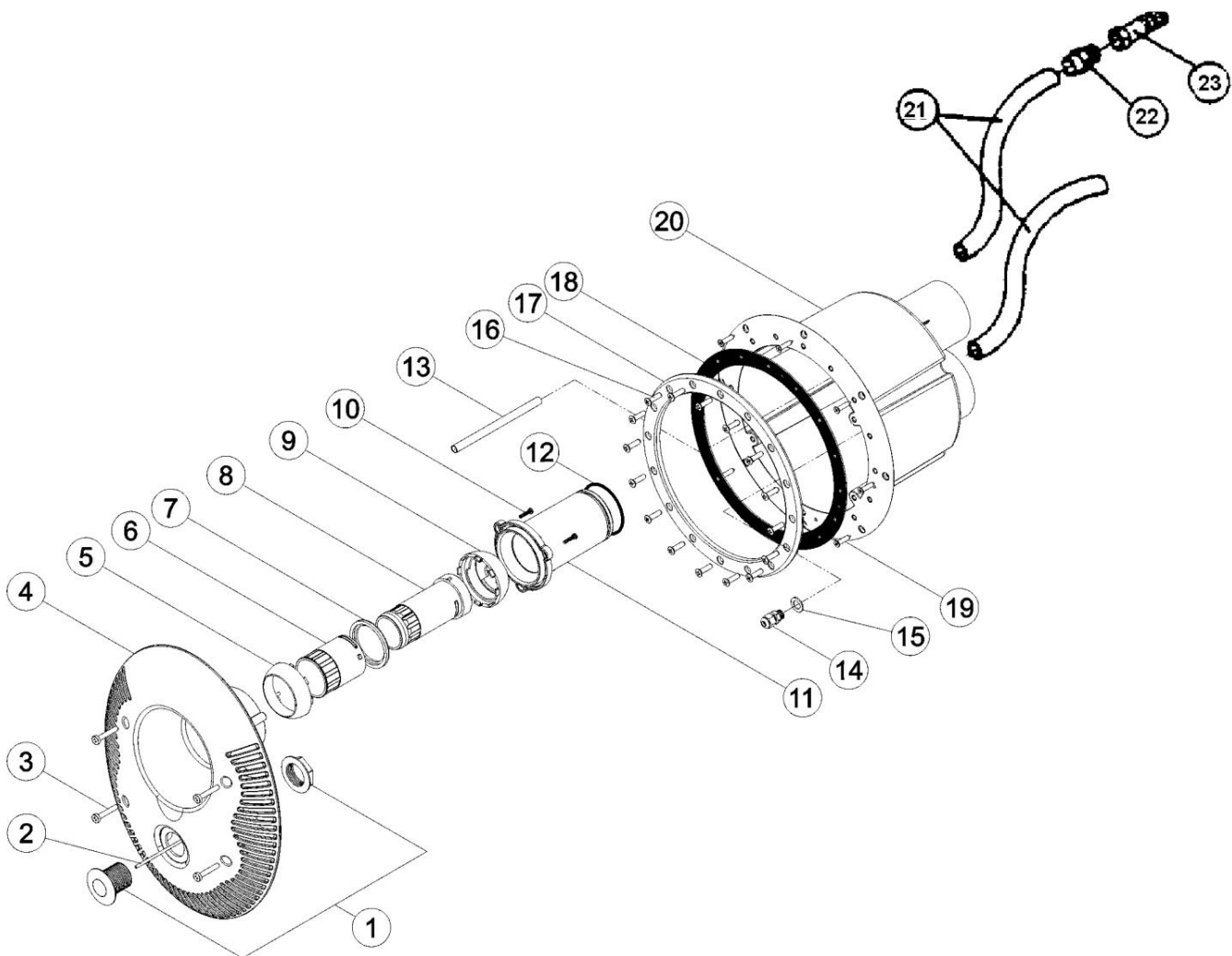

Fig. 8

10. Electrical Installation - WARNING

The electrical installation works should be performed by authorised technician acc. to generally binding regulations and standards.

Main power supply voltage shall correspond to the value specified on label fixed to each equipment. All system metal components must be bonded (grounded). Electric characteristics / regulations of circuit breaking elements shall comply with characteristics / regulations applicable for motor, which is to be secured with expected operating conditions. All instructions specified by the manufacturer shall be adhered to (see data on label). At devices with three-phase motor, the clamps in the termination board between the motor windings must be properly positioned (star connection). Input and output wires from the distribution box must be lead through the penetration elements preventing entry of humidity and dirt into the distribution box.

The wires shall be fitted with proper connecting terminals / clamps.

The electric-pneumatic panel shall be installed in dry location above the water level and at distance to 7m from the pneumatic switch at the counterflow face.

The pneumatic hose (pos. 2, Fig. 3) is intended for connection to the electric-pneumatic switch at the electric-pneumatic panel (switchboard). It must be checked, whether the hose is not bent at any point.

The electric-pneumatic panel consists from following parts: 1 Motor protection

- 1 Electric-pneumatic switch
- 1 Control fuse.

All these parts should be installed in water-proof plastic box with insulation protection IP55.

Note: Detailed information on installation, protection and maintenance see Electric-Pneumatic Panel Instruction Manual.

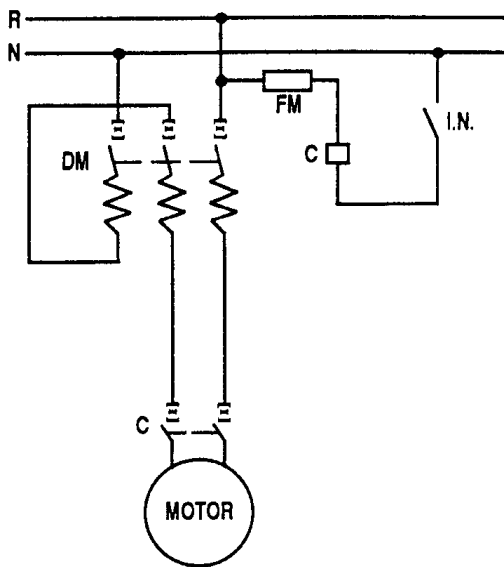

Fig. 9

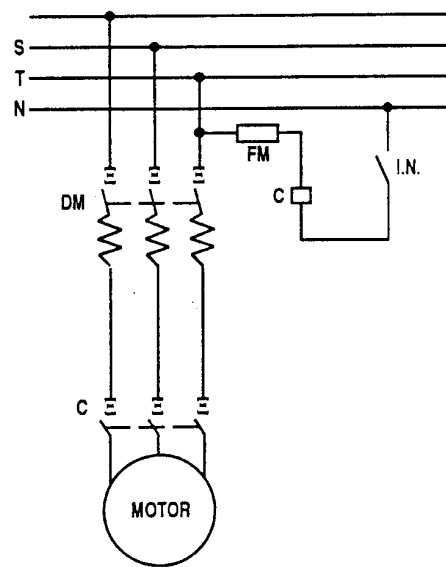

Fig. 10

FM - Control Fuse,
Contactor

DM - Motor Thermal Protection,

I.N. - Electric-Pneumatic Switching Unit,

C -

11. V-JET Counterflow Pump

The V-JET counterflow is fitted with NEW BCC pump in single-phase variant for 230V and in three-phase variant for 400V, electric input power 2.2kW ; 3.0kW and 4.1kW.

Dimensions see Fig. 11, performance characteristics see Fig. 12

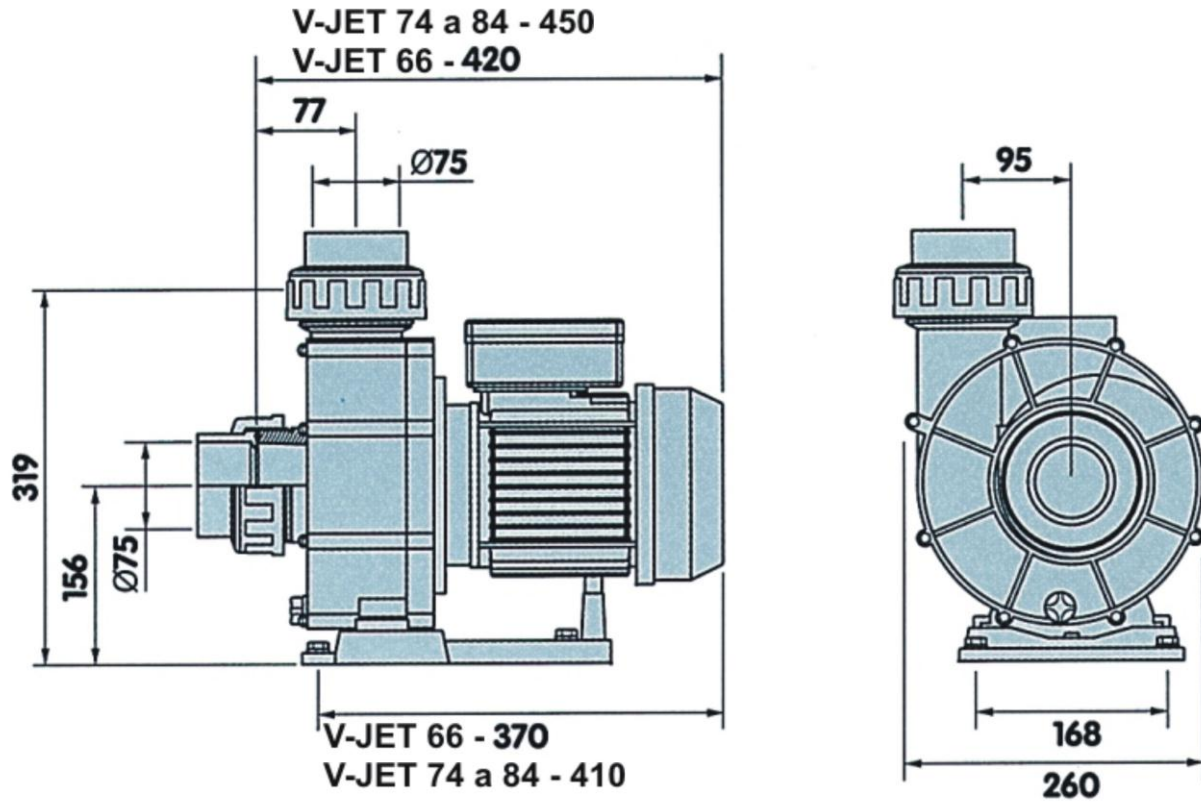

Fig. 11

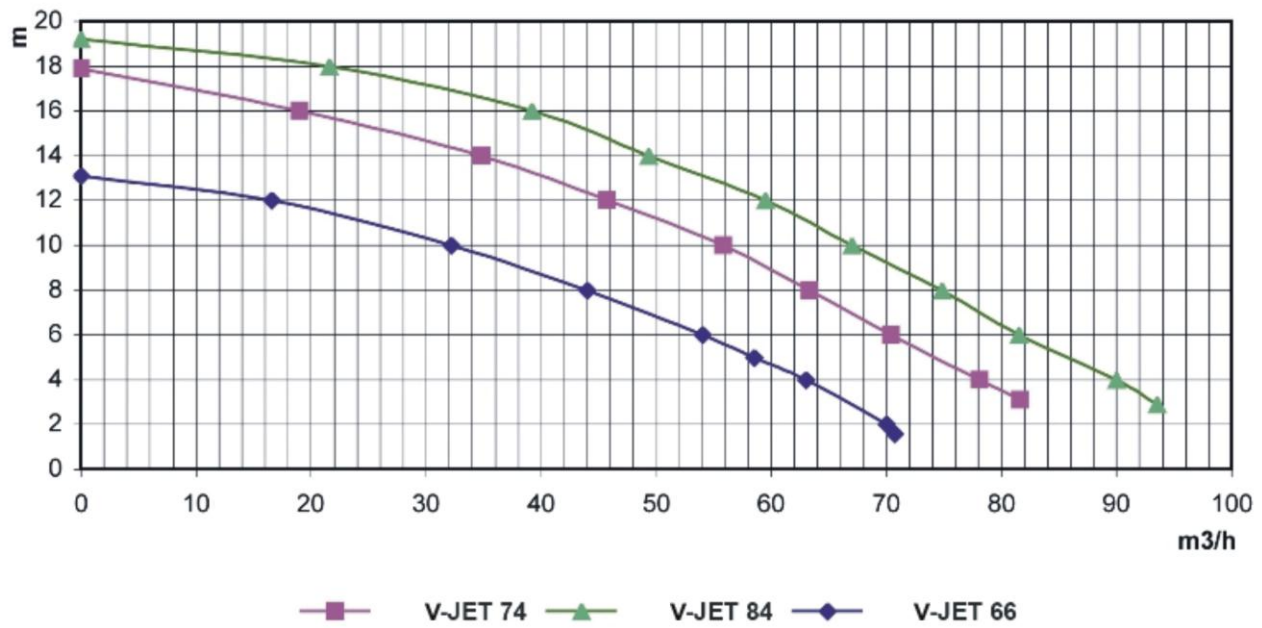

Fig. 12