

UltraSieve® III

Patent nr: NL 1026138 / EP 1593305 / US 2005/0258188-A1



Instruction Manual

Introduction

The UltraSieve is a pre-filter to filter waste solids from the water. This technique is based upon the sieve-bend. A sieve-bend consists of hundreds of sharp stainless steel profile wires with very small slot openings where the water can go through but the solids stay on the sieve bend (see picture below).

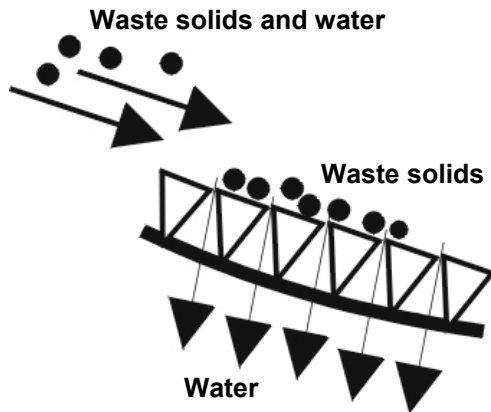

In practice it works as follows:

The water enters at **A** and will go upwards and fall over the “auto-adjustable” dam (**B**). The water goes through the sieve bend (**C**) and the waste solids will slowly go down to the waste area (**D**). At the waste outlet of the filter (**E**) is a 90mm sliding valve to easily wash away the waste with water. When the water in the tank underneath the sieve-bend will not be pumped away fast enough the water will raise which makes the floating system (**F & B**) go up to reduce the incoming water flow. The pump will be connected to the fitting 2” x 63mm(**G**). You can use a self-priming pump like a Whisperflo or Speck or a submersible pump that can be used out of the pond like the Oase and Messner series.

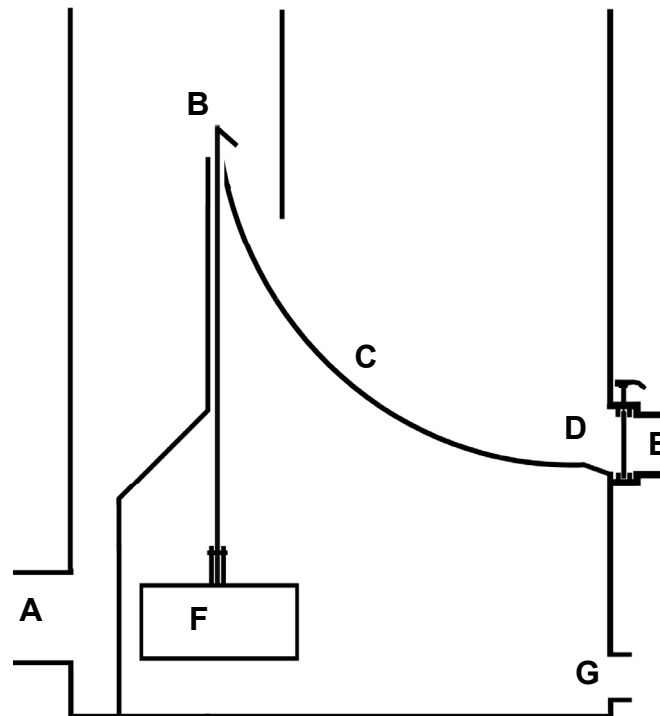

An extra advantage of this pre-filter is that the water will be provided with extra oxygen, when it goes through the slots.

UltraSieve Installation instructions

Please read these instructions before you start installing.

If you have some questions after reading this manual, please contact your UltraSieve dealer before you start installing to prevent mistakes.

The UltraSieve can be installed in 2 ways:

1. Gravity (pond fed), equal to the water level in a direct connection with the bottom drain (and/or skimmer)
2. Pump fed, above the ground with a free flow back to the pond.

Below you see a schematic drawing of a possible gravity installation

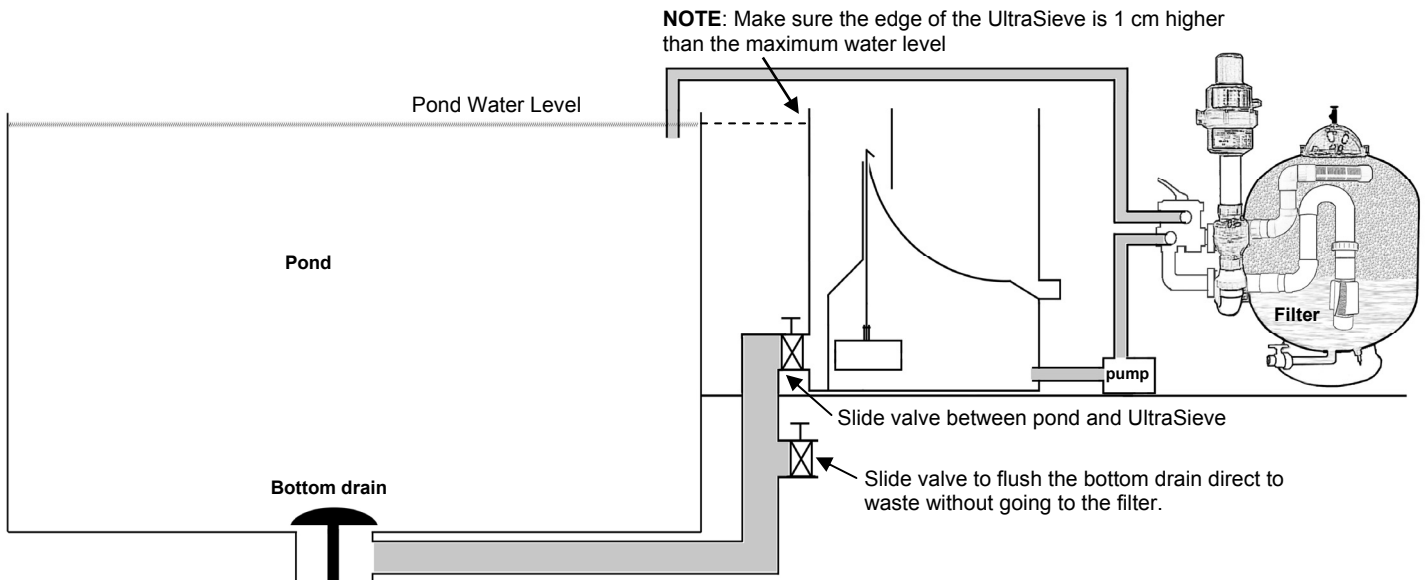

Make sure the UltraSieve is on an equal, level, underground. **The upper edge of the UltraSieve must be 1 cm above the maximum water level.** Between the bottom drain and the UltraSieve we strongly advise you to use a slide valve to separate the UltraSieve from the pond when necessary. The inlet of the UltraSieve is made of 110mm Polypropylene pipe so you can use a PVC push fit fitting. Since the UltraSieve is made of Polypropylene you cannot make glue connections. The UltraSieve has 2 inlets of 110 mm of which one is closed. If you want to use both inlets you have to cut off the end of the closed one. **Note: Do not install the UltraSieve directly in the soil! Make sure there is always enough room around the unit. When there is pressure on the unit it will not work properly.**

Pump connection

The pump outlet is made of a 2" PP male threaded connection. The UltraSieve is supplied with a PVC fitting 2" fem. thread x 63mm solvent. Please use Teflon tape or Loctite 5331 for the threaded connection. The maximum flow of the UltraSieve is about 30m³ per hour.

In case the pump sucks in air, because of the falling water near the pump exit, you can put the supplied piece (±45 cm) of pipe Ø50mm in the pump exit with some Teflon tape. Then, the pump will no longer take in the water from the "turbulent" part (A), but from the very "quiet" part underneath the float system (B).

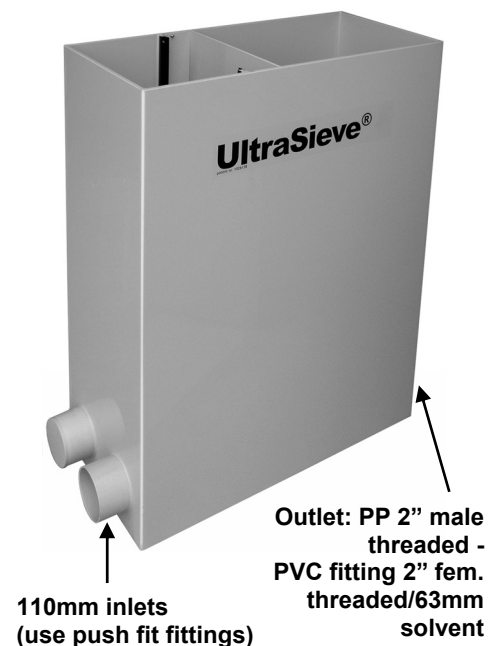
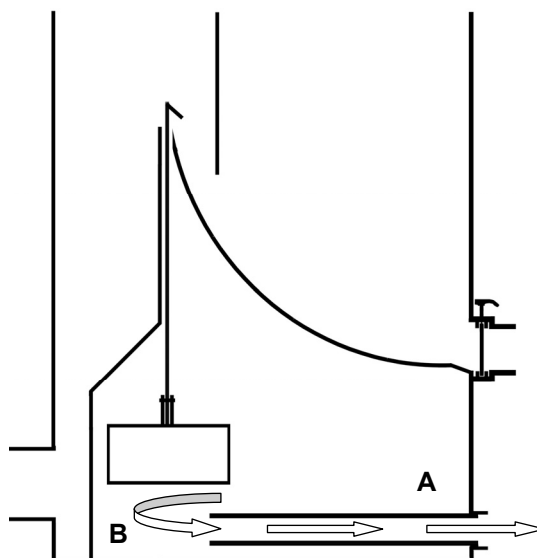

The auto-adjustable dam with floating device

The UltraSieve has a floating system to prevent the water in the area under the sieve from rising above the level of the sieve for low speed pumps and also to prevent the water from going too low to be primed for high speed pumps. The floating device can be installed at 3 different levels. You only have to do this once when installing the UltraSieve or when you change pumps.

Stainless bolts (10 millimeter) to adjust the height of the floating device

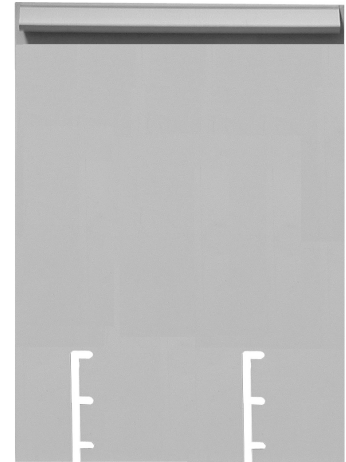
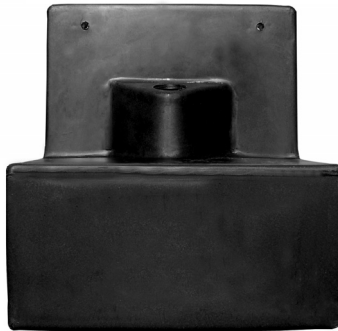
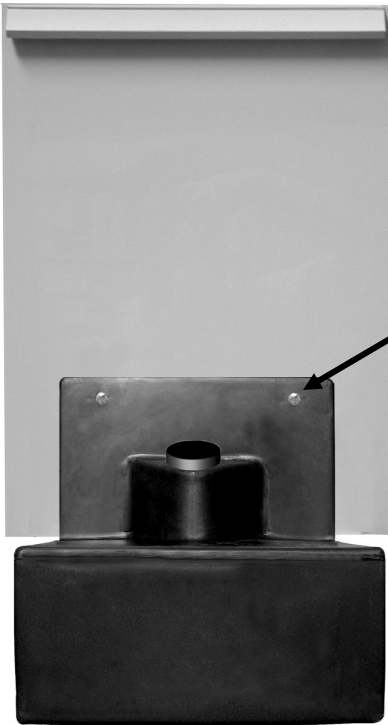

Procedure: loosen the 10mm bolts a little bit in order to move the floating device. **Note:** do not remove the bolts completely, a few millimetres is enough!
Push the floating device to the left in order to move it in the vertical opening. Choose one of the 3 levels and push the device to the right position. Fasten the bolts again. You're done.

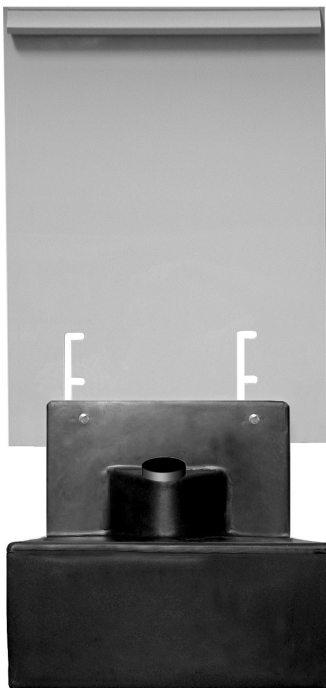

Level 1

This level gives the dam its maximum length, suitable for **pump speeds to $\pm 6-10\text{m}^3/\text{hour}$** .

The maximum length of the dam prevents the water level underneath the sieve from going too high for low speed pumps.

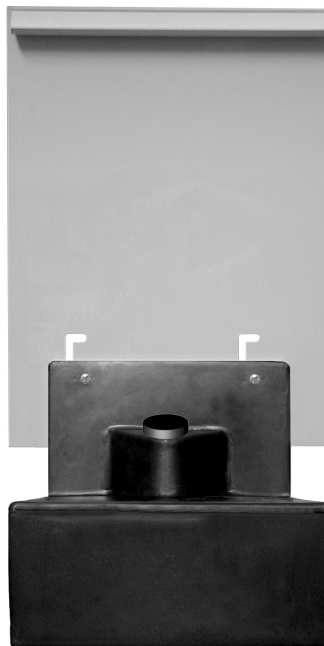

Level 2

This level gives the dam its middle length, suitable for **pump speeds to $\pm 12-16\text{m}^3/\text{hour}$** .

This length prevents the water from flooding the screen but also from going too low which causes priming problems.



Level 3

This level gives the dam its minimum length, suitable for **pump speeds $> 18\text{m}^3/\text{hour}$** .

The minimum length of the dam is to have a high water level under the screen to prevent a high speed pump from priming air.

Filling the floating device

Fill the unit with 3 litres of water for counter weight and put the plug in the hole.

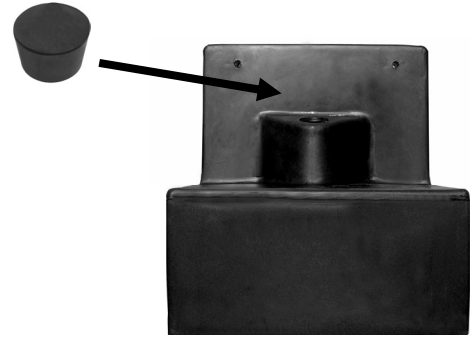

Pump fed application

When you want to use the UltraSieve above the water level with a submersible pump from the pond you must connect the pump hose to the 110mm inlet. The tank connector will then be used as the return flow to the pond. When this tank connector is too small in case of the pump speed you need to enlarge this connector.

In case the floating device is reducing the incoming water too much because the adjustable dam is floating too high you can remove the floating device completely. In this case you will always have the maximum capacity.

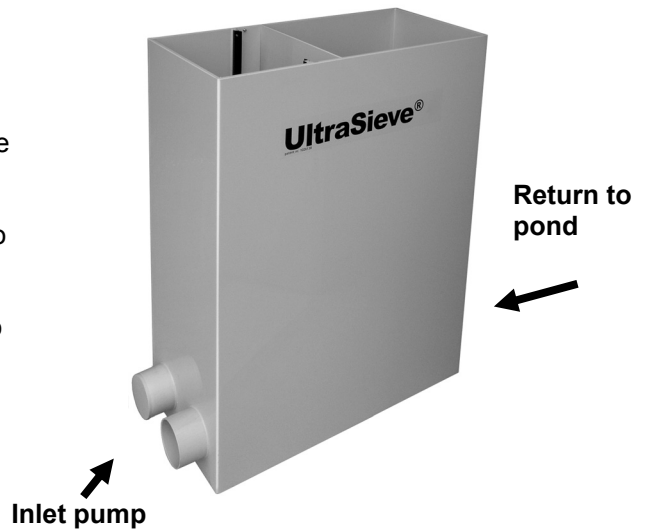

Waste outlet

The waste outlet is provided with a 90mm Valterra slidevalve for easy clearance of the waste. Supplied with the filter is a small PVC pipe that fits around the slide valve. You can glue this piece of pipe around the slide valve the obtain a 110mm external pipe diameter for standard waste pipe connection.



Maintenance

It is advisable to monitor the UltraSieve every day. Maintenance is very easy because of the waste outlet. In fact maintenance is about two operations:

1. To remove the waste that is on the surface of the sieve (every day).
 2. To remove the waste that has gone into the profile wires of the sieve (only when necessary).
1. Removing the waste that is on the surface of the sieve is very easy by opening the waste outlet and to rinse the waste away with a normal hose pipe. Another method to have water run over the screen is pushing down the adjustable dam which will flood the screen with water. When the adjustable dam is in a low position already because of the pump speed you can pull up the dam for a short while and push it back downwards again.
 2. To remove the waste that has gone into the profile wires of the sieve you will need a hose pipe with a powerful spray nozzle or a high-pressure machine. For this way of cleaning you have to place the sieve in an upright position or take the sieve out of the unit.

After a certain period of time the sieve can get “fat” and this will make it more difficult for the water to go through. You can clean the sieve with i.e. alcohol.

Note: when you use the sieve for the very first time the surface of the sieve can also be covered with a very thin film. Make sure you will clean the sieve very thorough with alcohol before using it.

Removing the sieve

First remove the water “guide” (A) from the unit.
Now you can take out the sieve for maintenance.

Removing the floating device and the adjustable dam

First remove the floating device completely from the dam by loosening the stainless (10mm) bolt (as explained at page 3). To remove the dam you need to remove the stainless screw (B) from the unit in order to slide the dam completely out of the unit. This screw normally prevents the dam from moving up too high.

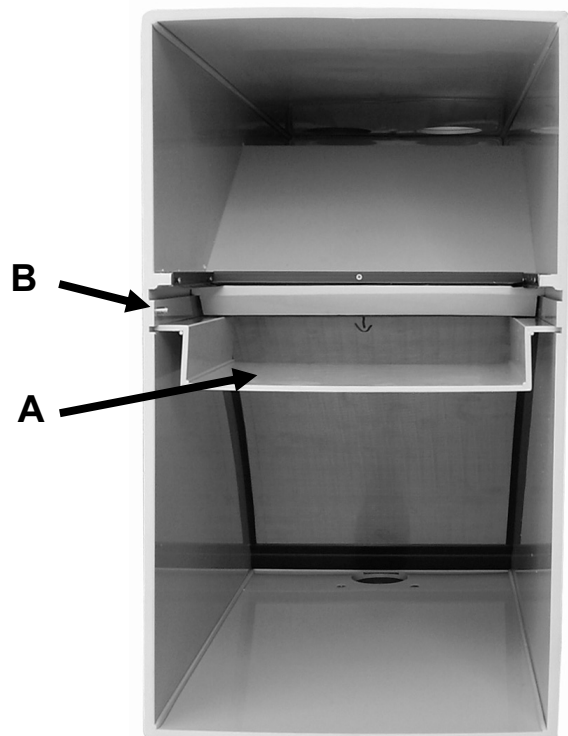

Technical Specifications

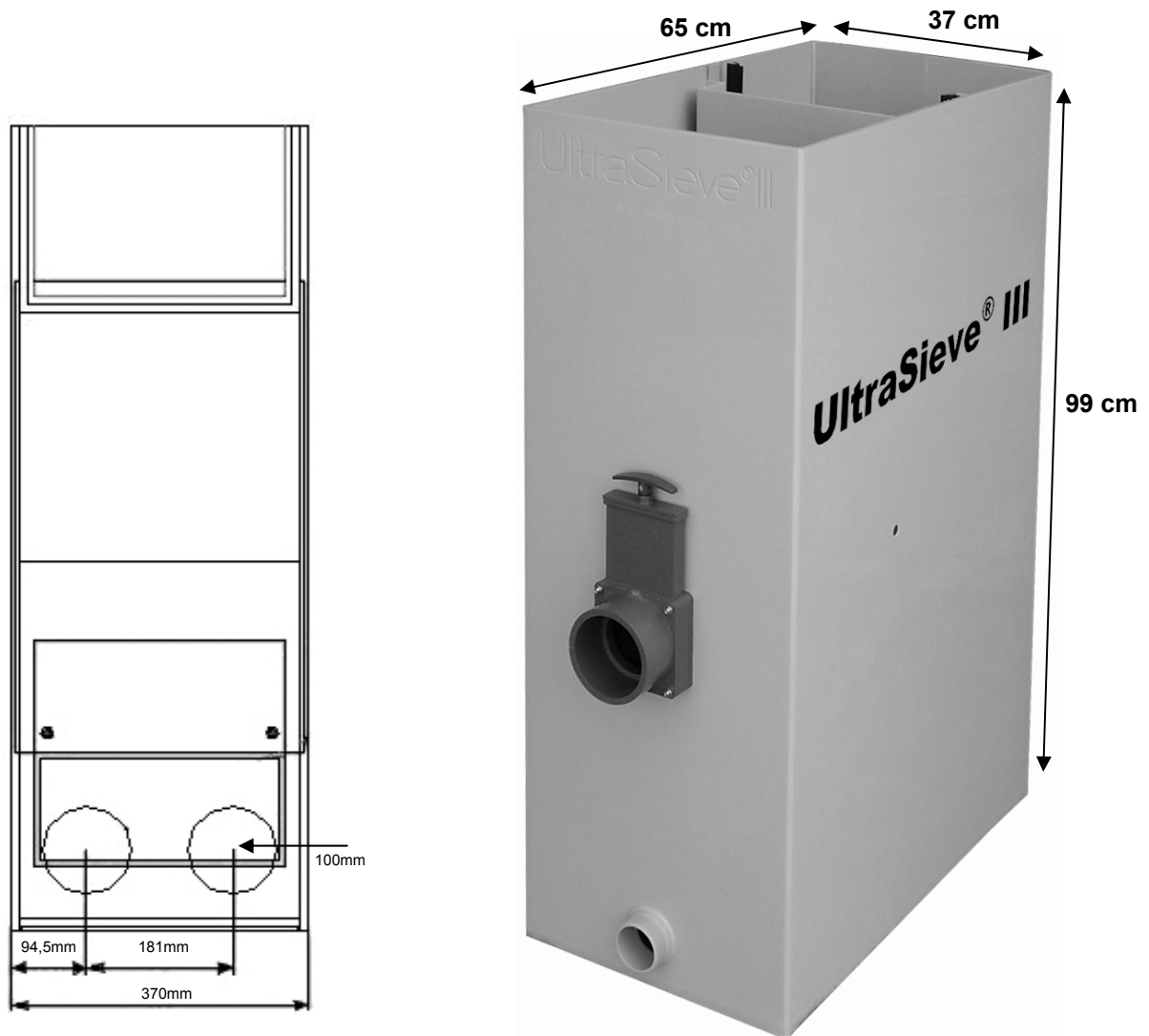

	SIZE	MATERIAL	EXTRA INFO
HOUSING	65 x 37 x 99 cm	1 cm polypropylene plate	
INLET	110 mm spigot	Polypropylene	2 x 110 mm inlet
OUTLET	2" male threaded 2" female threaded x 63mm ID	2" male threaded = PP 2" female threaded x 63mm ID = PVC solvent	
WASTE	90/110mm valve	PVC	Valterra 90mm
SIEVE BEND	345 x 450 mm	Stainless Steel 316	Available in 200 - or 300 micron
CAPACITY			Max. about 30m ³ /hour
WEIGHT			±28 Kg Including sieve bend