

DECORATIVE RING LUMIPLUS FLEXINICHE

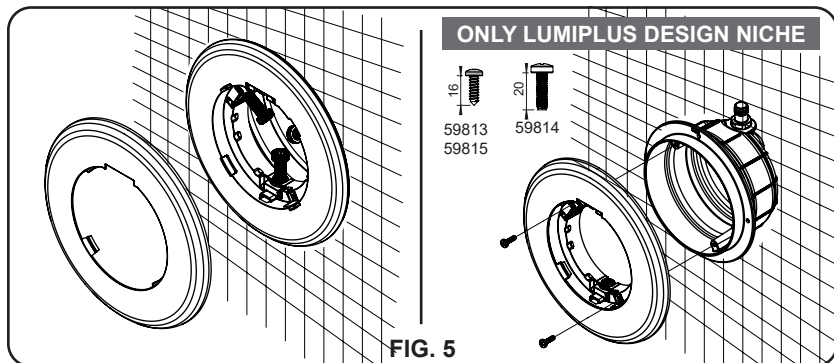

INSTALLATION MANUAL

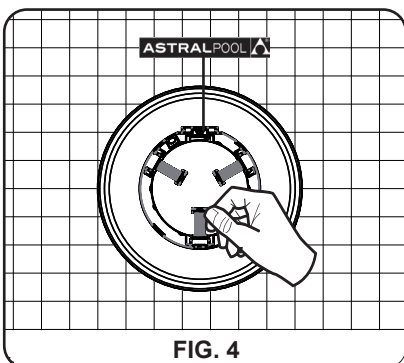

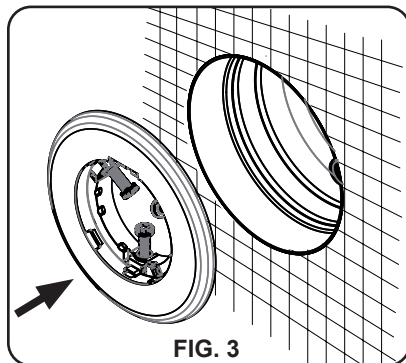
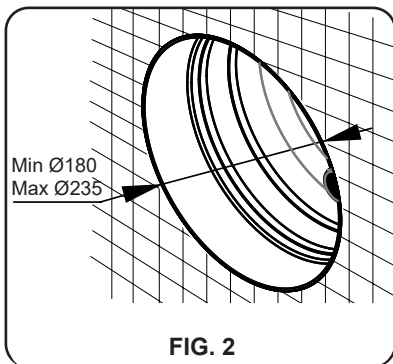
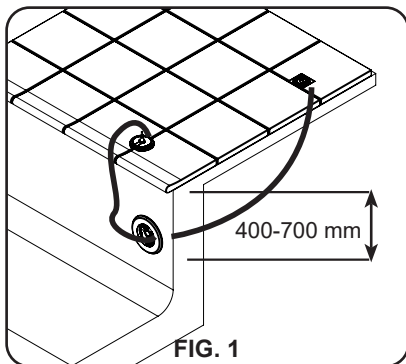
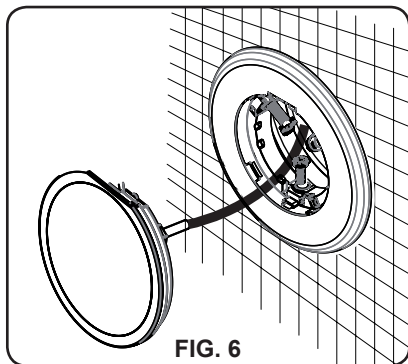

FIG. 6

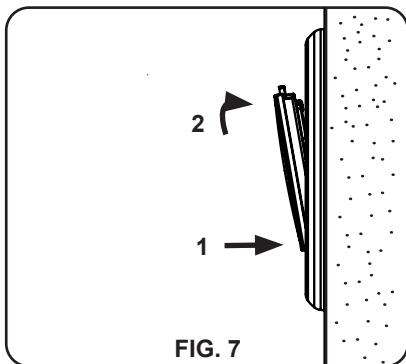

FIG. 7

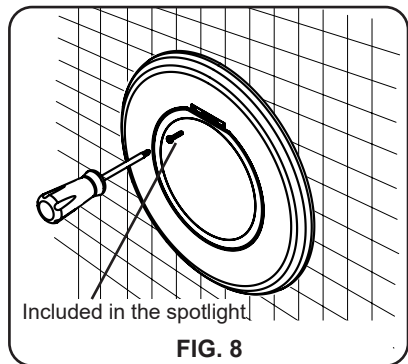

FIG. 8

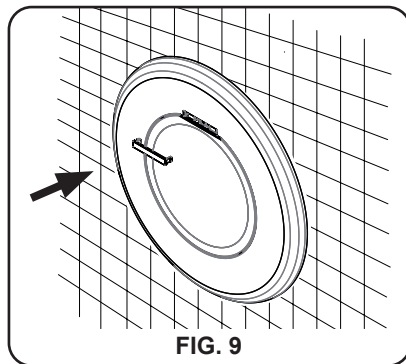
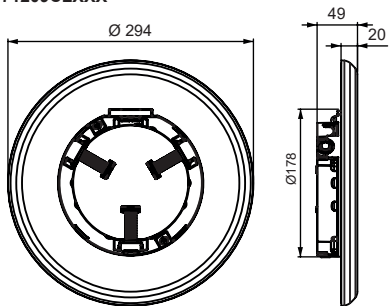

FIG. 9

- If the spotlight is to be replaced, disassemble in reverse order.

TECHNICAL CHARACTERISTICS

71209CLXXX



71209IP41CLXXX

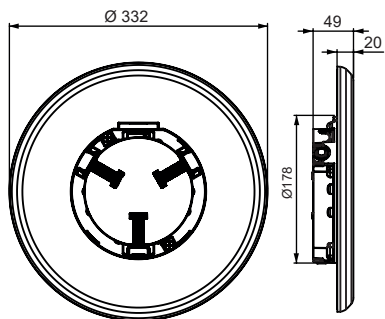

Made in Spain

Sacopa, S.A.U.

Pol. Ind. Poliger Sud - Sector I

17854 Sant Jaume de Llierca (Spain)

ASTRALPOOL

Avda. Francesc Macià, 60, planta 20
08208 Sabadell (Barcelona) Spain

- We reserve to change all or part of the articles or contents of this document, without prior notice.