

*User Manual*  
**ProfiDrum**



Manufacturer information:

ProfiDrum  
Lopik  
Tel: +31 (0) 348-551801  
E-mail: [info@profidrum.com](mailto:info@profidrum.com)  
[www.profidrum.com](http://www.profidrum.com)

## Index

Introduction	3
Adjustments	3
Factory information	4
Contents of the package	4
Profile drumfilter	5
Connection to supply and drain pipes	6
Pump-fed arrangement	8
Connecting the waste disposal container on the sewer	10
Connecting the high pressure pump and spraybar	11
Controlbox	13
Connecting engines	10
Standard controlbox with opened case	14
Adjusting level probes and low water protection	16
Managing the controlbox	16
Test run after connecting the components	17
Intervals between rinses	17
Maintenance	17
Statement of marked points	17
Disclaimer	18
Important safety warnings	18
Final accountability	19

## **Introductie**

### ***Congratulations with the purchase of your ProfiDrum filter!***

With the purchase of this drum filter you now own a high quality product which was built with the utmost care and precision.

Please read carefully and follow all instructions and tips before you install the drum filter.

If you have any questions, please do not hesitate to contact your dealer.

This manual is a simple guide to installing your drum filter.

We recommend making a copy of the manual to keep in the immediate vicinity of your drum filter.

Our drum filters are suitable for gravity-or pump-fed lines.

## **Adjustments**

Drum filters are in collaboration and marked with independent consultancy Euronorm BV, CE.

Adjustments to Profi Drum drum filters that are made without the prior permission of the manufacturer are not covered by the guarantee. When adjustments are done without permission the CE marking, and guarantee expire.

*Use only original spare parts supplied by us for repairs.  
Spare parts can be ordered from the manufacturer or your dealer.*

## **Factory information**

You can find the type / model designation on the rating plate of your drum filter.

EC declaration

### **Manufacturer**

ProfiDrum Holland  
Sluisweg 5  
3412 LA Lopik

Model Type: ProfiDrum 45/55/65/65E/75<sup>E</sup> and CombiBio 15/30/50

ProfiDrum model designation on the label on the drum filter

### **Applied CE Directives:**

- New Machinery Directive (2006/42/EC)
- Low Voltage Directive (2006/95/EC)
- EMC Directive (2004/108/EC)

### **Applied standards:**

- NEN-EN-ISO 12100-1
- NEN-EN-IEC 60204-1

The manufacturer declares to have complied with the safety requirements which are determined from the safety requirements of the Machinery Directive. This product also overlaps with the safety requirements from the LVD and EMC directives.

## **Contents of the package**

Your drumfilter is supplied with automatic control.

On all models a standard high pressure pump is supplied.

## Profile drumfilter

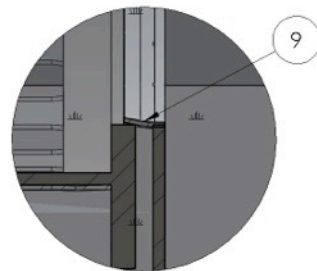
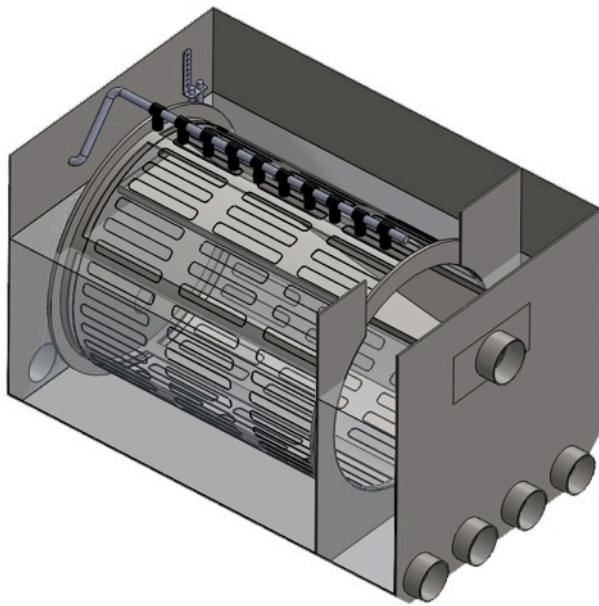

DETAIL D  
SCALE 1 : 2

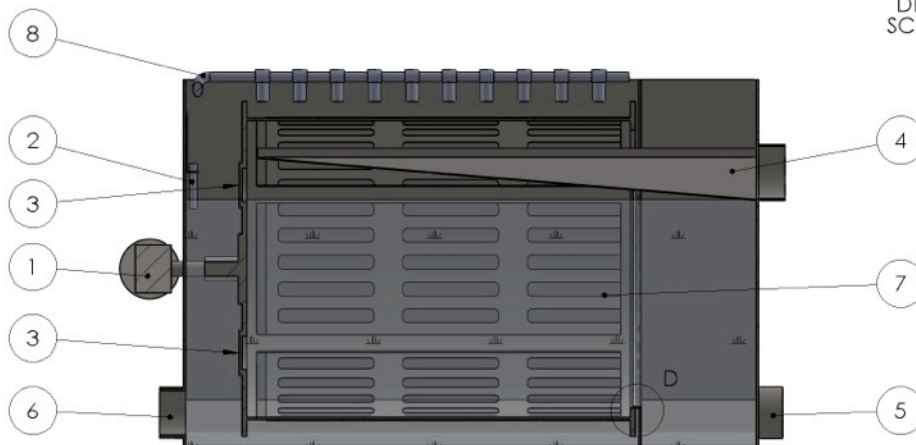

- 1 Drummotor
- 2 Sensor
- 3 By-Pass
- 4 Waste disposal
- 5 Water imports, from pond
- 6 Water exports, to pump(s)
- 7 Drum with panels
- 8 Nozzles
- 9 Seal

## Connecting your drumfilter in GRAVITY arrangement

Place the drum filter on a solid surface that is completely level. You can then connect the supply and return pipes \* 1 of the drum to the pond or your filter. They easily connect with sleeves and / or bends with a collar, or a rubber sock. The size of the required PVC materials is 110 mm. It is advisable to place the landing on the front side of the drum filter to provide a slide valve. **Note: Always switch off the control!**

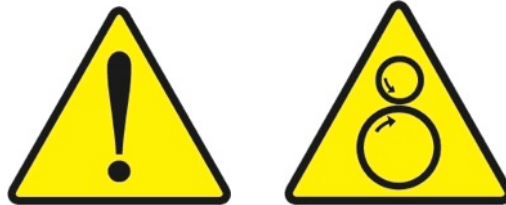

Set the drum so that the water level is even with the top of the silicone sealing strip. By setting the water level at this height you use the most surface area of the screen of the drum filter.



*Water level adjustment*

If you do not have enough supply piping, or the bends in the piping cause too much resistance, there is the option to place the drum in such a way that the water level is slightly above the top of the silicon strip (gravity situation) state. Please note that all pumps are off.

**GRAVITY arrangement, not flush situation, probe touches water**

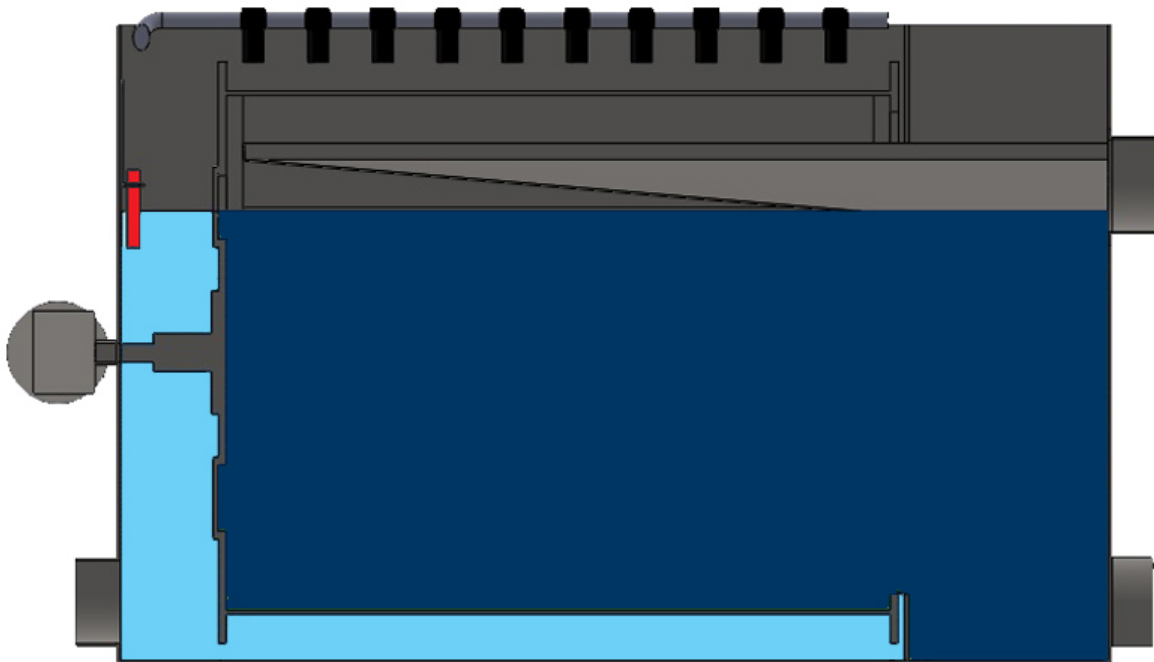

**GRAVITY arrangement, flush situation, probe is dry**

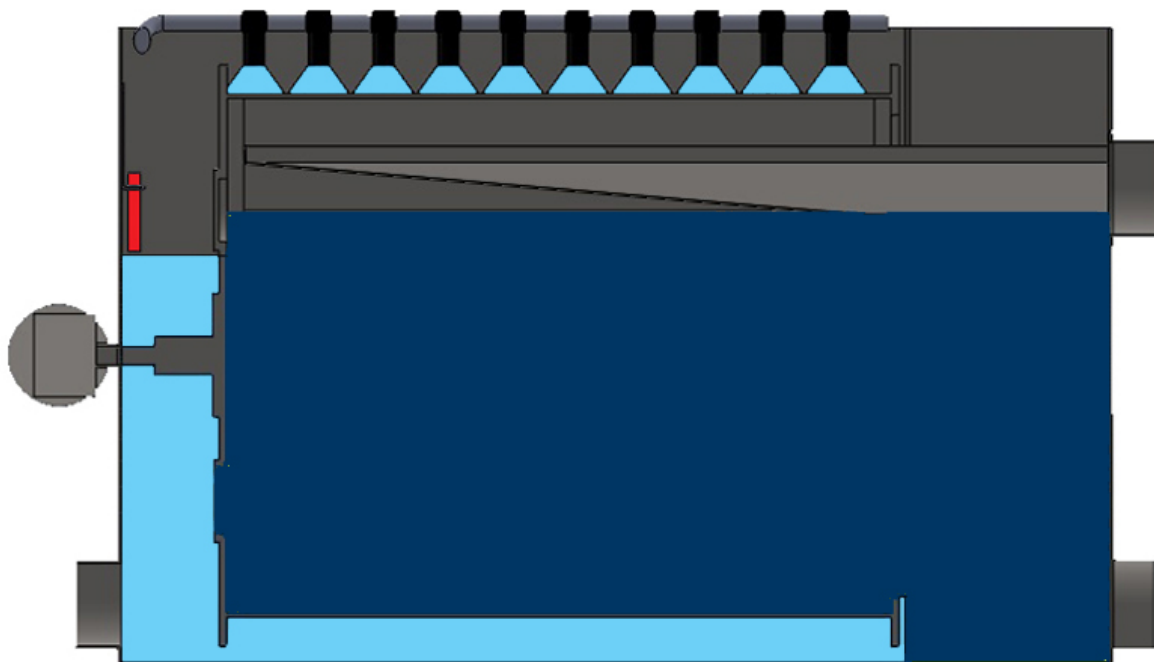

Darkblue is not filtered water.  
Blue is filtered water.

## **Pump-fed arrangement**

1. Place the drum mesh tray on a solid surface that is completely level.
2. Connect a number of inputs to the front of the drum filter.
3. Then connect the pump(s) to one of the remaining input(s). If necessary, you have to get an adapter to the connector of the pump you are using.
4. Then, extend the outputs on the back of the drumfilter in such a way that the top of the outflow bend is at the same height of the top of the horizontal beam at the front. Move the probe level of the back of the drum to the front side of the drum in the collecting compartment.



**Pump-fed arrangement, not flush situation, probe is dry**

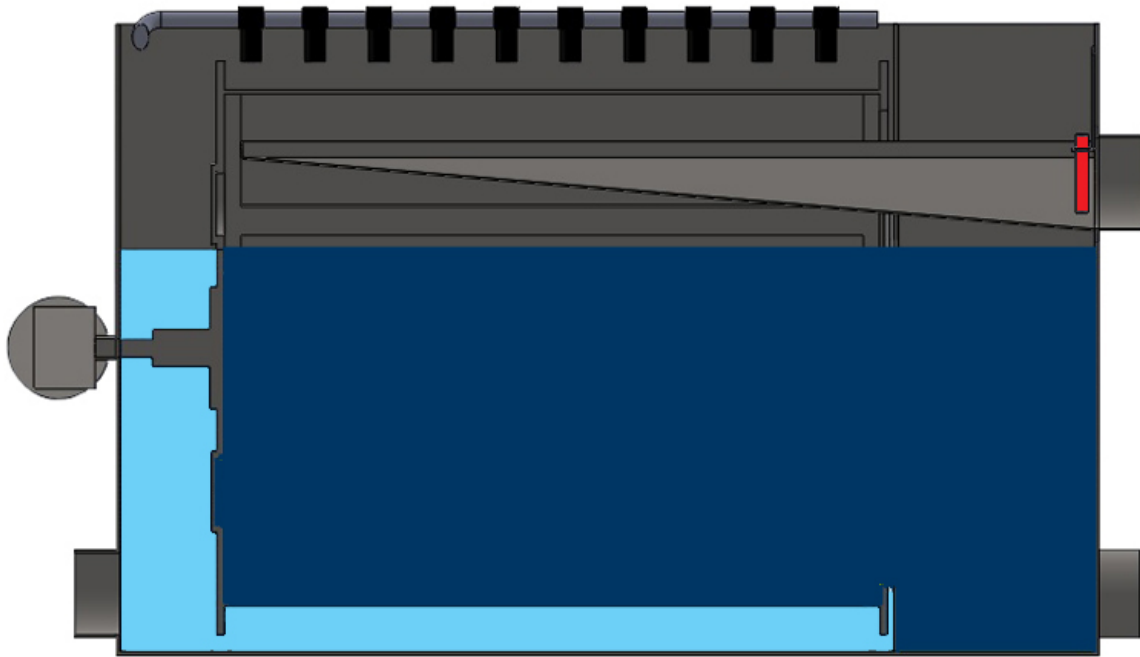

**Pump-fed arrangement, not flush situation, probe touches water**

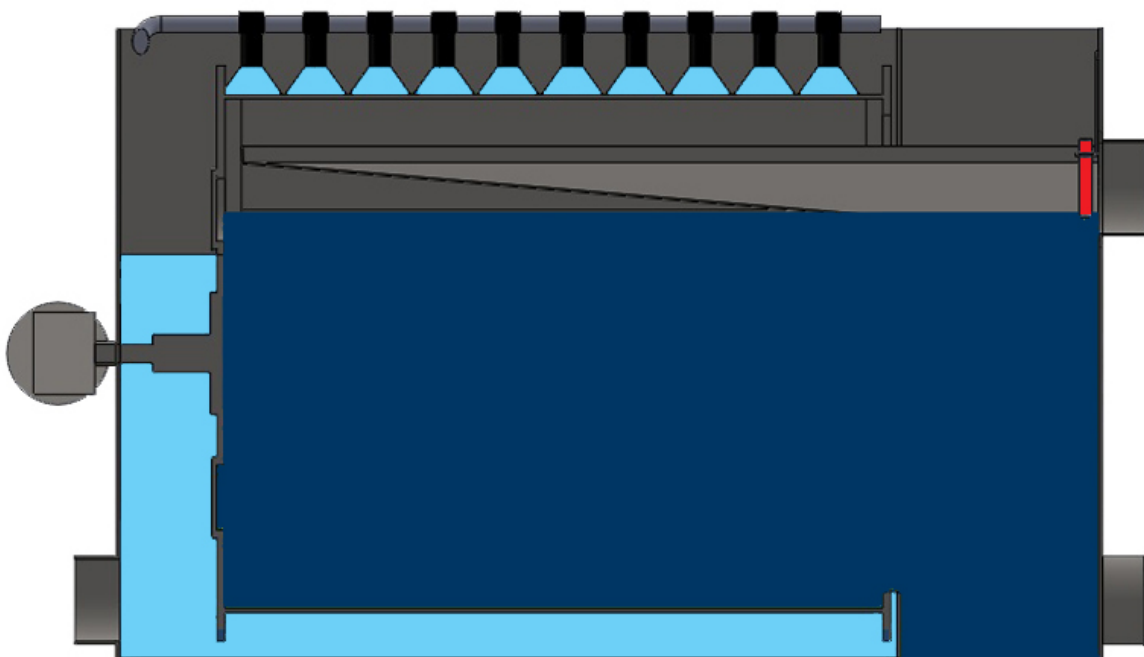

## Connecting the waste disposal container on the sewer

After connecting the supply tubes connect the tube \* 2 (waste) to a drain pipe to the sewer.



*Front ProfiDrum Eco range.  
Front of the drum connection with waste disposal,  
top tube.*

## **Connecting the high pressure pump and spraybar**

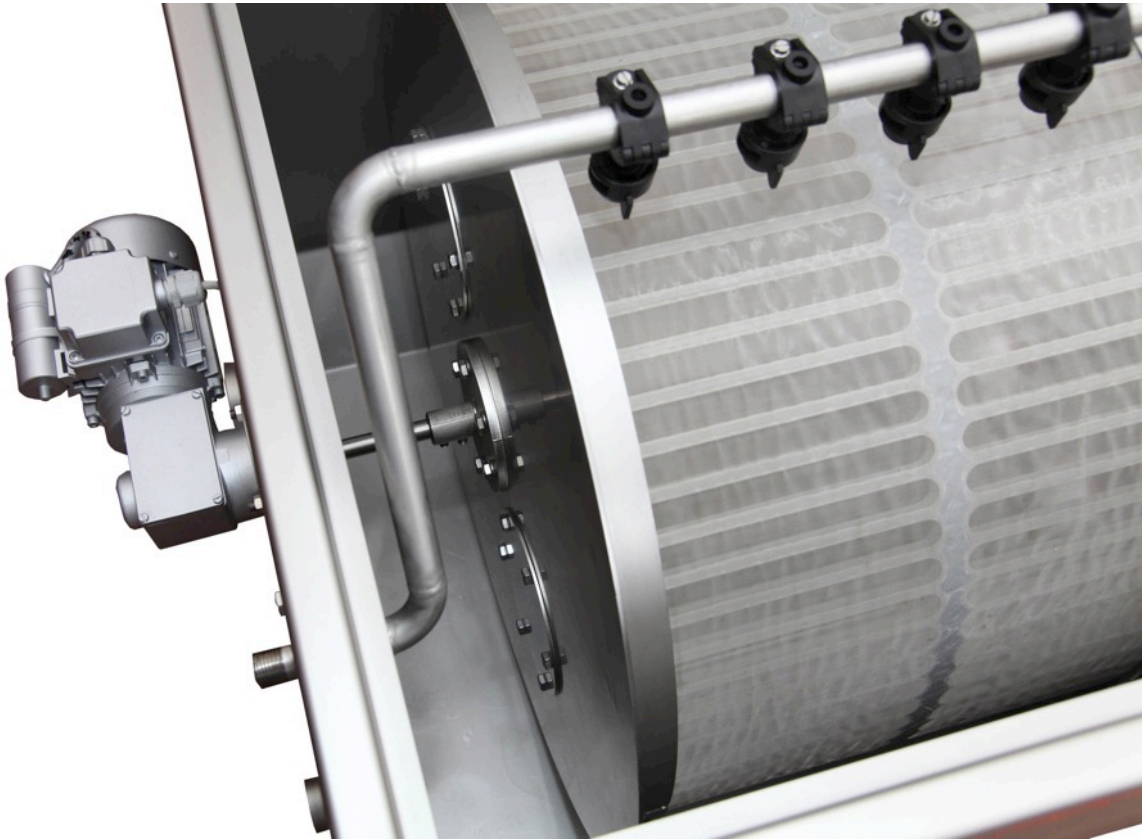

*Spraybar with ½ inch connection.*

## **Connecting the high pressure pump to the inlet of the drum.**

If you only work with a high pressure pump, connect the vertical inlet (suction side) of the high pressure pump (see picture pump) to the bottom of the drum 1 inch suction inlet<sup>3</sup> of the drum.

*Suction and spray-bar connection to the drum filter.*



## Connecting the spraybar on the high pressure pump

Then connect the discharge side of the high pressure pump to the spraybar. You work with a high pressure pump and therefore it is advisable to work with flexible hose. This prevents resonances in the pipes.



*High pressure pump*

*Suction side is located on the front of the pump.  
The compression side is located on the top side of the pump.*



## Controlbox

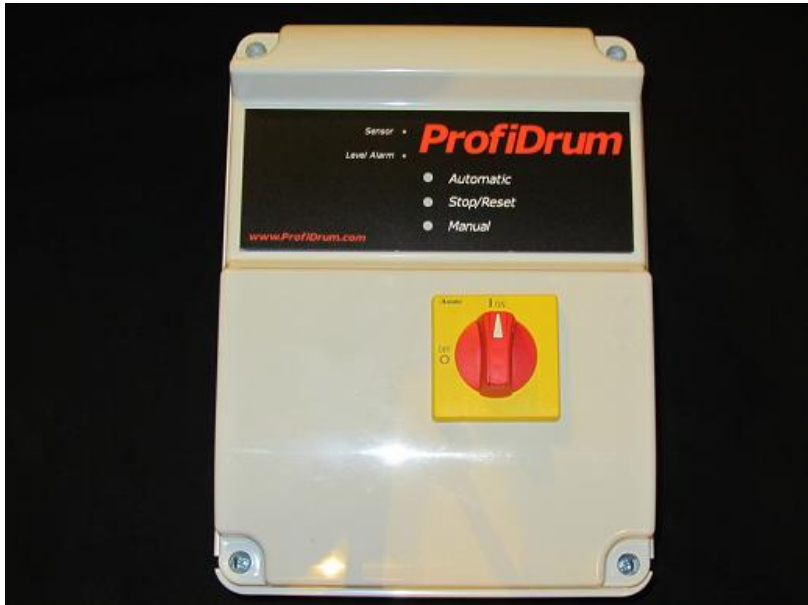

### *Control box*

At the front of the control box are the:

- Main
- Automatic
- Stop/reset Switch
- Manual/test Switch

### Connecting drum motor and high pressure pump on the controlbox

The box of your drum filter may differ. The drum filter is available with a standard box or with a Siemens Logo PLC controlled system. This depends on the choice of the box that you selected during the purchase.



## Standard control with opened case

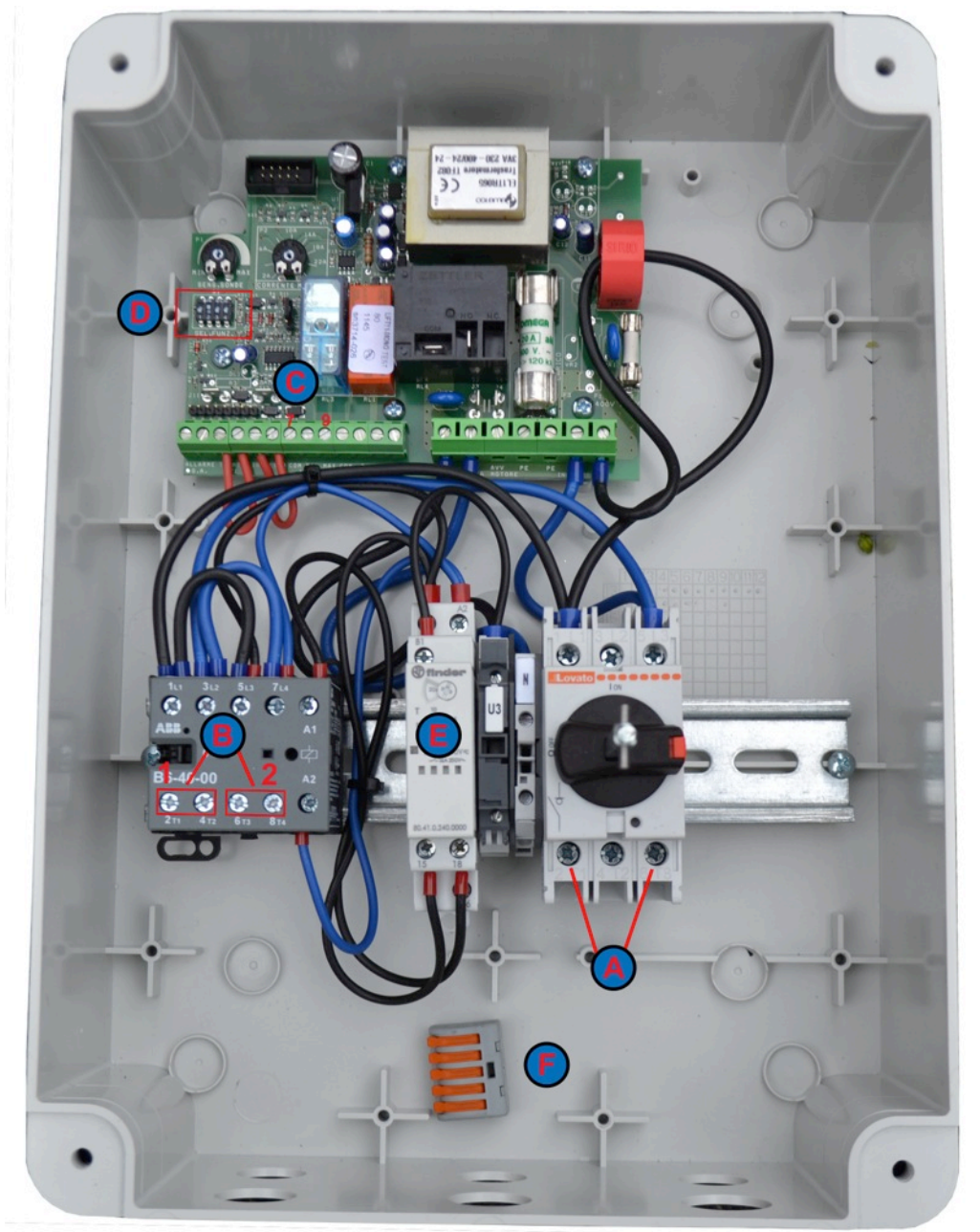

*Standard controlbox*

### **Terminal hookup:**

A	Power	
B.1	High pressure pump	
B.2	Gearbox	
C	7 and 9	Probes
D	1 = down. 2 = up. 3 en 4 = down	Gravity
	1 = up. 2, 3 en 4 = down	Pumped
E	Timer	
F	Mass block	

## **Connecting the motor and high pressure pump to the control box**

1. Turn the main switch to the OFF position, and loosen the 4 screws of the cover, and remove the cover.
2. Now connect the motor, high pressure pump, sensors and power supply to the numbered items in the control box. The screws 3 and 5 on the PCB (A) are used on the connecting cable from the probe to hold in place. This is a connection with low voltage.
3. The wire of the high pressure pump relay block B 1.
4. The wire of the motor connects to relay block B 2.
5. The power supply connects to the relay block v.d. switch, Figure 1 and C 2.
6. Then connect all ground wires (green / yellow) to the ground block D.



## Adjusting level probes and low water protection

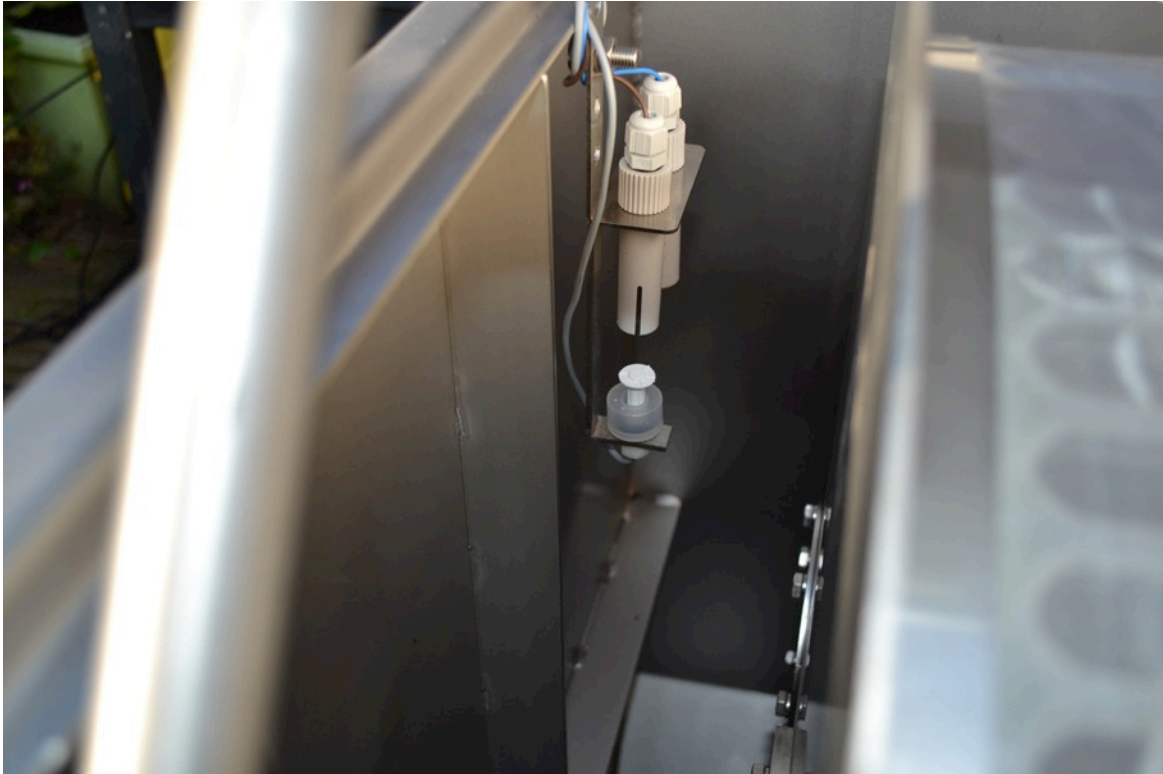

*Probes*

Your filter drum is equipped with two probes.

Once one of the 2 probes no longer in contact with water, the control box will turn on your drum filter. It also turns on the high-pressure pump and cleans your cloth. This cleaning process takes 10 seconds and during this process the contaminated water is discharged through the waste piping. If you want the intervals between the flush times to lengthen or shorten, you can raise or lower the probe by hanging the bracket in the predrilled holes.

You have a level height adjustment range of approximately 50 mm.

### Dry run protection

For a small extra charge you can purchase an additional bracket and switch. You connect the additional switch to the screws 1 and 2 on the green circuit board. This switch must be attached 30 mm below the probe. See Figure 1 Figure 1 and 2 a 1

You should also remove the red wire.

## **Test run after connecting the components.**

After connecting everything you should check the drum filter for correct operation. It is wise to all check components and connections for leaks.

By turning the red safety button on the front control box to the ON position to set the drum filter in operation.



## **Intervals between the rinses**

It is normal that the drum filter in the early stage of filtering frequently rinses. Unfortunately, there is no indication of why because this is highly dependent on the situation. The intervals between the rinse cycles are therefore largely determined by factors such as, pollution of the lake and its floating debris. Also, the surface of the drum in combination with the fineness of the mesh, have direct influence on the intervals between the flushing times. The intervals between the rinsing times may also vary due to the seasons.

## **Maintenance**

It is advisable to periodically clean the screen with a hydrochloric acid solution <10. This maintenance should be done two to three times per year, but is strongly dependent on the situation. In general, if the intervals between the rinsing times become shorter, the cloth has to be cleaned. **Caution with hydrochloric acid. / It is corrosive, therefore always take the appropriate measures.**



## **Declaration of marked points**

- \* <sup>1</sup> Exact size is 109 mm. It is preferred to work with a rubber cuff.
- \* <sup>2</sup> Diameter waste duct model ECO 45 is 90 mm.  
All other models is 108 mm.
- \* <sup>3</sup> If your pond water is used for rinsing, it is recommended that a refill system turns on to bring up your water level automatically.

## Disclaimer

1. This disclaimer applies to:
  - the owner: the owner of the website;
  - user(s): all possible actions;
  - you: the user of this information and our products;
  - the content: all that the website contains;
2. The following applies to the page you are currently viewing. Our guide and this page, you agree to this disclaimer.
3. The content has been put together by the owner with the utmost care, however, the owner accepts no liability for any inaccuracies in the displayed.
4. The owner is not responsible for content on this website linked files and / or websites referenced.
5. Unauthorized or improper use of the content or parts thereof infringe intellectual property rights
6. Permission to use the displayed content or parts thereof in public places must be requested in writing to us.
7. See our terms and conditions.

### Important safety warnings



Corrosive substances



Rotating / moving parts



Electrical hazard



Danger

*ProfiDrum is not liable for damages or injuries that occur as a result of not correctly following and / or neglect of the directions that are prepared in the Professional Drum manual.*

All rights are expressly reserved to Profi Drum.  
All our deliveries are general conditions apply.