

The Xclear gravity fed Sieve is a pre-filter to filter waste solids from the water. This technique is based upon the sieve-bend screen. A sieve bend screen consists of hundreds of sharp stainless steel profile wires with very small slot openings where the water can go through but the solids stay on the sieve bend (see picture).

### In practice it works as follows:

The water enters at **A** and will go upwards and fall over at **B**. The water goes through the sieve bend (**C**) and the waste solids will slowly go down to the waste area (**D**). At the waste outlet of the filter (**E**) is a sliding valve to easily wash away the waste with water. When the water in the tank underneath the sieve-bend will not be pumped away fast enough the water will rise which makes the floater (**F**) go up. The float is connected to a pipe that will push down the bended plate (**G**) to reduce the incoming water flow. The pump will be connected to the pipe (**H**). This pipe and the water guide (**I**) will prevent the pump from sucking in air bubbles. An extra advantage of this pre-filter is that the water will be provided with extra oxygen, when it goes through the slots.

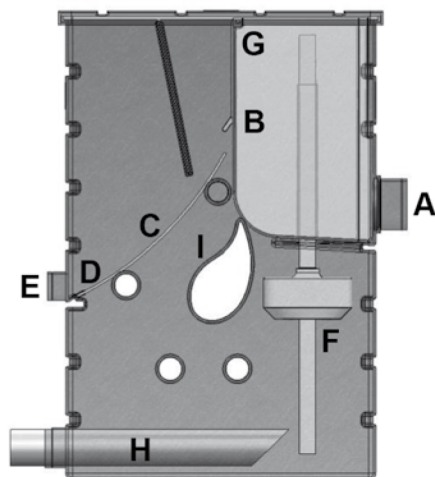

Please read these instructions before you start installing. If you have some questions after reading this manual, please contact your Xclear Sieve dealer before you start installing to prevent mistakes. Gravity (pond fed), equal to the water level in a direct connection with the bottom drain (and/or skimmer). Below you see a schematic drawing of a possible gravity installation

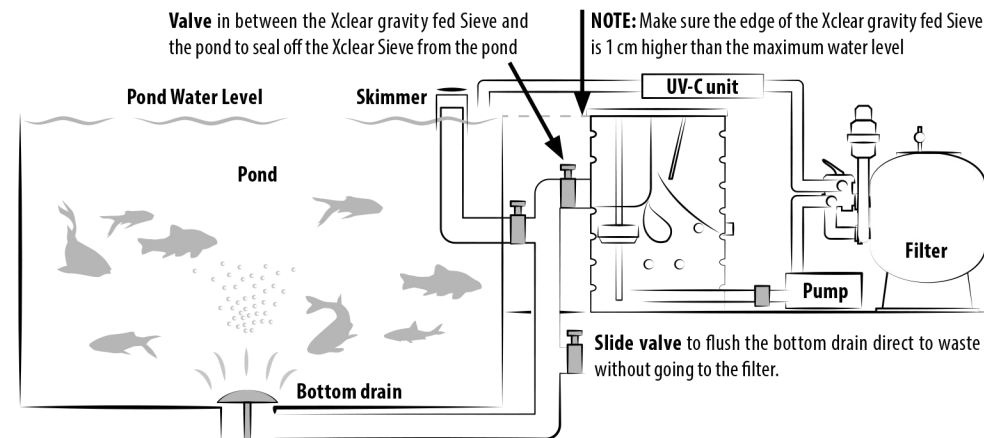

Make sure the Xclear Sieve is on an equal, level, underground. The upper edge of the Xclear Sieve must be 1 cm above the maximum water level. Between the bottom drain and the Xclear Sieve we strongly advise you to use a slide valve to separate the Xclear Sieve from the pond when necessary.

### INLETS

The inlets of the Xclear gravity fed Sieve are made of 110mm (4") PE pipe on which you can use the supplied flexible boot fittings. Since the Xclear Sieve is made of PE you cannot make glue connections. The Xclear Sieve has 2 inlets of 110 mm (4") of which one can be closed with the supplied flexible end cap.





### FLOATER

The Xclear Sieve floater must be filled with  $\pm 500\text{ml}$  ( $\pm 1$  pint) of water to give it some counterweight. Fill the gap after filling by pushing the supplied rubber cap firmly into the hole.

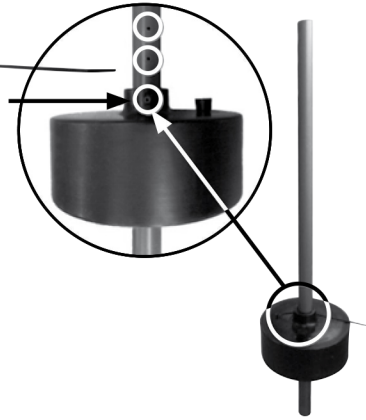

### MOUNTING THE FLOATER

The floater height on the supplied PVC pipe will determine the water level underneath the sieve screen when the pump is running. You can fasten the float with the supplied cable tie wrap. Before you secure the tie wrap, first test the correct height by just sticking the tie wrap through the holes of the float and PVC pipe! The highest position is for high flow rates ( $20\text{--}25\text{m}^3/\text{h}$ ), lowest position is for low flow rates ( $\pm 5\text{m}^3/\text{h}$ ). The PVC pipe has 4 holes.

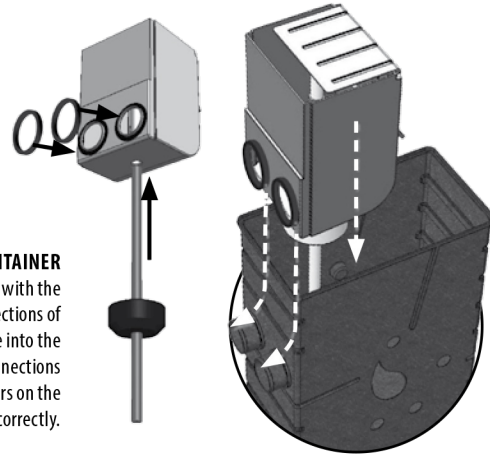

### MOUNTING THE INNER CONTAINER

The inner container must be sealed at the pipe connections with the supplied rubber foam rings. Fix them around the pipe connections of the inner container and lower the container with the float pipe into the Xclear Sieve. Firmly push the inner container into the pipe connections for maximum sealing results. You can check with your fingers on the inside of the container if the rubber rings are positioned correctly.

### WASTE OUTLET

The Xclear gravity fed Sieve comes with a 63mm (2") waste outlet that can be connected to the supplied 50mm slide valve with the supplied flexible socket.

### PUMP CONNECTION

The Xclear Sieve comes with a flexible reducer fitting of 90 x 63mm (3" to 2"). The 90mm/3" part fits on the pump outlet of the Xclear Sieve and the 63mm/2" part can be used to push a 63mm/2" pipe through towards the end of the Xclear gravity fed Sieve to prevent the pump from sucking in air bubbles.

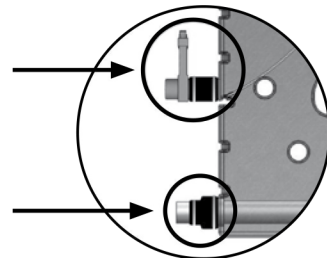

## MAINTENANCE

It is recommended to monitor the Xclear Sieve every day. Maintenance is very easy because of the waste outlet. In fact maintenance is about two operations:

1. To remove the waste that is on the surface of the sieve (every day).
2. To remove the waste that has gone into the profile wires of the sieve (only when necessary).

1. Removing the waste that is on the surface of the sieve is very easy by opening the waste outlet and to rinse the waste away with a normal hose pipe. Another method to have water run over the screen is to open the adjustable weir (G) which will flood the screen with water. When the adjustable weir is in a fully open position already because of the pump speed you can push it closed for a short while and open it again.

2. To remove the waste that has gone into the profile wires of the sieve you will need a hose pipe with a powerful spray nozzle or a high-pressure machine. For this way of cleaning you have to place the sieve in an upright position or take the sieve out of the unit.

**Note: when you use the sieve for the very first time the surface of the sieve can also be covered with a very thin film. Make sure you will clean the sieve very thorough with alcohol before using it.**

**xclear**  
UV-C & FILTERS  
**SIEVE**  
GRAVITY FED

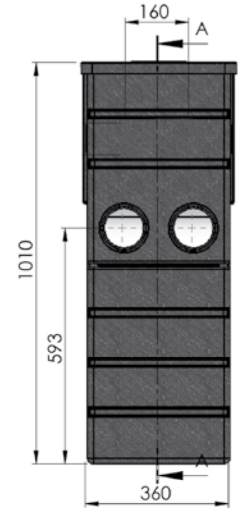

TECHNICAL SPECIFICATIONS			
	SIZE	MATERIAL	EXTRA INFO
HOUSING	67 x 36 x 101 cm	PE	Lid included
INLET	110 mm outer $\emptyset$	PE	2 x 110 mm (4") inlet
PUMP OUTLET	90 mm outer $\emptyset$	PE	Comes with 90/63mm (3 x 2") flex. fitting
WASTE	63 mm	PVC Slidevalve	Comes with 63/50mm (2 x 1½") flex. fitting
SIEVE BEND	450 x 345 mm	SS 304	300 micron
CAPACITY			Max. 25 m <sup>3</sup> /h
WEIGHT			$\pm 15$ Kg. Incl. screen

Xclear is a trademark of VGE BV Son & Breugel [www.vgebv.nl](http://www.vgebv.nl) copyright VGE BV version 1.01 2013