

Operation & Service Manual

BADU[®]JET super-sport //

Counter Swimming Unit



Technical Support:

Address: Speck Pumps
8125 Bayberry Road
Jacksonville, FL. 32256
USA

Hours: (Monday - Friday) 8:00 am to 5:00 pm EST

Toll Free: 800-223-8538

Phone: 904-739-2626

Fax: 904-737-5261

Website: www.usa.speck-pumps.com

Manufactured by Speck Pumps, Jacksonville Florida USA, © 2016 All Rights Reserved.
This document is subject to change without notice.

Safety

Safety is emphasized throughout the user manual. These are safety alert symbols (**CAUTION, WARNING, and DANGER**). They alert the user of potential personal injury hazards. Obey all safety messages to avoid possible injury or death or damage to equipment.

Date of Installation:	
Installed by:	
Serial Number:	
For Service Call:	

Table of Contents

1	<i>Important Safety Instructions</i>	4
	SwimJet Combination Fitting Manufacturers Warnings. . .	4
	General Safety Instructions.	5
2	<i>General Description</i>	6
3	<i>Operation</i>	7
	Controls Overview.	7
	Basic Operations	7
	Getting Started	7
4	<i>Service and Maintenance</i>	8
	Priming the Pump	8
	Testing GFCI	8
	Nozzle Adjustment	9
	Winterizing	10
5	<i>Frequently Asked Questions</i>	10
	Trouble Shooting	11
6	<i>Product Specification</i>	14
	Replacement Parts and Exploded View	14
7	<i>Limited Warranty</i>	16

BaduJet super-sport // Certifications



VGB 2008

1 Important Safety Instructions

WARNING: Before Installing this product, read and follow all warning notices and instructions which are included. Failure to follow safety warnings and instructions can result in severe injury, death, or property damage. Call (800) 223-8538 or visit www.usa.speck-pumps.com for additional copies of these instructions.

Swim Jet Combination Fitting - Manufacturers Warnings

MUST BE INSTALLED by an experienced and qualified pool industry professional **ONLY**.

Attention Installer: This manual contains important information about installation, operation, and safe use of this product. This information should be given to the owner and/or operator of this equipment. Most Federal, State and Local codes regulate the construction, installation and operation of pools and spas. It is important to comply with these codes, many of which regulate the installation and use of this product.

1. **DO NOT** locate this fitting in seating areas or on the back rests for such seating areas.
2. This fitting should be mounted in the vertical pool wall only per manufacturer's instructions.
3. All fittings and fasteners should be examined for damage or tampering before each use.
4. Any missing, broken, or cracked fittings must be replaced before using this product. Only genuine Speck replacement parts may be used.
5. Acceptable fittings/pipe sizes are listed on page 9 of the installation manual. No other sizes are permitted.
6. Never exceed the maximum flow rate stated on this product.
7. The anti-entrapment cover must be in place when using this product. **DO NOT** use this product if the cover is missing, broke or loose.
8. The anti-entrapment cover (part# 93.1) should be replaced within 10 years from installation date.
9. Installation requires a Phillips screw driver. All screws should be hand tight only. **DO NOT** use electrical or air drills.
10. Consult your physician before exercising with the BaduJet super-sport or using the massage hose.
11. **DO NOT** permit children to use this product unless they are closely supervised at all times.
12. **DO NOT** remove any safety alert labels such as **DANGER, WARNING, or CAUTION**. Keep safety alert labels in good condition and replace missing or damaged labels.
13. Stay alert, watch what you are doing and use common sense. **DO NOT** use unit if you are tired and/or exhausted. **DO NOT** use unit while under the influence of drugs, alcohol, or any medications.
14. **CAUTION: DO NOT** increase pump size; this will increase the flow rate through the system and exceed the maximum flow rate stated on this product.

IMPROPER INSTALLATION OR USE OF THIS PRODUCT MAY PRESENT A RISK OF HAIR OR BODY ENTRAPMENT AND DROWNING. Install this equipment in accordance with the instructions provided.

Swim Jet Combination Fitting - Manufacturers Warnings - continued

As the manufacturer, Speck Pumps - Pool Products, Inc., hereby certifies that their Swim Jet Combination Fitting meets or exceeds the requirements of the Virginia Graeme Baker Pool & Spa Safety Act, VGB 2008 and ANSI/APSP 16 standards and safety regulations as set forth by the Consumer Products Safety Commission.

“Read, and then keep these instructions for future reference”

General Safety Instructions

The following guidelines provide information to minimize the risk of injury to users of pools, spas, and hot tubs.

WARNING: TO REDUCE THE RISK OF ENTRAPMENT HAZARD



Pool and spa pumps produce high levels of suction, which can pose extreme danger if a person comes in close proximity to an open pool or spa drain or if a drain cover is loose, cracked, broken or missing. Pool and spa pumps move large volumes of water, which can pose extreme danger if a person's hair comes in close proximity to a drain that is not the proper size for the pump or pumps.

If not an approved single, unblockable outlet, a minimum of two functioning suction outlets per pump must be installed. Suction outlets in the same plane (i.e. floor or wall) must be installed a minimum of three (3) feet (1 meter) apart, as measured from center point to center point. Dual suction fittings shall not be located on seating areas or on the backrest for such seating areas. If any suction outlets are located closer they shall be located on two different planes (i.e. one on the bottom and one on the vertical wall, or one each on two separate vertical walls).

WARNING: Failure to keep suction outlet components clear of debris, such as leaves, dirt, hair, paper and other material can result in an increased potential for suction entrapment.

If not a single, unblockable outlet, in the event of one suction outlet being completely blocked, the remaining suction outlets serving the system shall have a flow rating capable of the full flow of the pump(s) or the specific suction system. If in doubt about the rating and/or head loss curve of your system, consult a qualified pool or spa professional and/or your respective equipment manufacturer(s). Also, double check with your local building/health authorities regarding single vs. multiple drain installations, etc.

Regularly inspect all drain covers for cracks, damage and advanced weathering. If a drain cover becomes loose, cracked, damaged, broken or is missing, close the pool or spa immediately, post a notice and keep the pool or spa closed until an appropriate VGB 2008 certified drain cover is properly installed.

WATER VELOCITY AND FLOW RATES

The maximum water velocity through drain covers is limited by some local regulations, for example some state health departments limit the velocity through public pool drain covers to 1.5 feet per second. This velocity limit is lower than the flow rating provided by the ANSI/APSP 16 certification; therefore local limit applies and must be followed. Never exceed the flow rating listed on the cover even if local code does not provide a velocity limit.

For additional information on proper installation refer to The Association of Pool & Spa Professionals ANSI/APSP-7 Standard and the US Consumer Product Safety Commission Guidelines for Entrapment Hazard.

General Safety Instructions - continued

VGB Compliance - VIRGINIA GRAEME BAKER POOL AND SPA SAFETY ACT

The Virginia Graeme Baker Pool and Spa Safety Act raises certain new requirements on owners and operators of swimming pools and spas.

Pools or spas constructed on or after December 19, 2008, shall utilize:

- (A) No submerged suction outlets, a gravity drainage system with ANSI/APSP compliant cover(s), one or more unblockable outlets; or
- (B) A multiple main drain system without isolation capability with suction outlet covers that meet ANSI/APSP 16-2011 Suction Fittings for Use in Swimming Pools, Wading Pools, Spas, and Hot Tubs and either:
 - (i) A safety vacuum release system (SVRS) meeting ASME/ANSI A112.19.17 Manufactured Safety Vacuum Release Systems (SVRS) for Residential and Commercial Swimming Pool, Spa, Hot Tub, and Wading Pool Suction Systems and/or ASTM F2387 Standard Specification for Manufactured Safety Vacuum Release Systems (SVRS) for Swimming Pools, Spas and Hot Tubs or
 - (ii) A properly designed and tested suction-limiting vent system or
 - (iii) An automatic pump shut-off system.

Pools and spas constructed prior to December 19, 2008, with a single submerged suction outlet shall use a suction outlet cover that meets ANSI/APSP 16-2011 and either:

- (A) A multiple main drain system without isolation capability, or a single (VGB 2008 compliant) unblockable suction outlet, or
- (B) A safety vacuum release system (SVRS) meeting ASME/ANSI A112.19.17 and/or ASTM F2387, or
- (C) A properly designed and tested suction-limiting vent system, or
- (D) An automatic pump shut-off system, or
- (E) Disabled submerged outlets, or
- (F) Suction outlets shall be reconfigured into return inlets.

For more information about the Virginia Graeme Baker Pool and Spa Safety Act, contact the Consumer Product Safety Commission at (301) 504-7908 or visit www.cpsc.gov.

WARNING: Risk of Electrical Shock or Electrocution

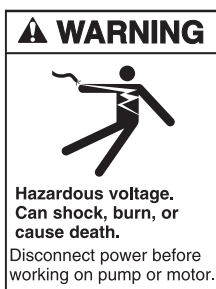

Pool pump must be installed by a licensed or certified electrician or a qualified pool serviceman in accordance with the National Electrical Code and all applicable local codes and ordinances. Improper installation will create an electric hazard which could result in death or serious injury to pool users, installers, or others due to electrical shock, and may also cause damage to property.

Always disconnect power to the pool pump at the circuit breaker before servicing the pump. Failure to do so could result in death or serious injury to serviceman, pool users, or others due to electric shock.

2 General Description

The BaduJet super-sport II from Speck Pumps has been designed to be installed during the construction of your pool to create a water treadmill for anyone wanting a therapeutic and effective exercise. The BaduJet super-sport II can be installed in any type of pool, large or small, from gunite to vinyl liner. The self-contained, flush-mounted unit is a jet-propulsion system that pumps water into the pool creating a current in excess of 5,700 gallons per minute from a recessed jet housing. Topping off the experience is the pulsating massage hose which can be attached to the jet nozzles for easy and convenient massage treatments for joints and muscles.

3 Operation

Controls Overview

- A. **Plastic Rectangular Cover**
- B. **Water Volume Control Knob:** This knob adjusts the amount of water flow through the jet nozzles.
- C. **Air Regulator Knob:** This adjusts the amount of air bubbles in the water flow.
- D. **System (ON/OFF) Button:** Turns the system ON/OFF.
- E. **Light (ON/OFF) Button:** Turns the low voltage LED light ON/OFF.
- F. **Adjustable Jet Nozzles:** Allows the user to angle the nozzles in any direction.

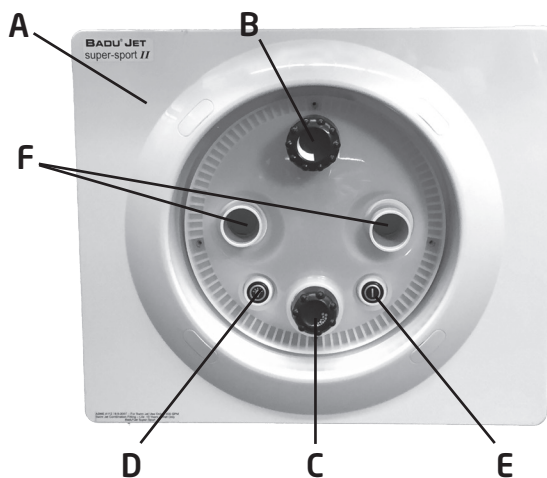

Figure 1 - BaduJet super-sport (Front View)

Basic Operation

WARNING: DO NOT use or operate the BaduJet super-sport if the anti-entrapment cover is missing, broken, or loose.

WARNING: To reduce the risk of injury, **DO NOT** permit children to use this product unless they are closely supervised at all times.

CAUTION: Consult your physician before attempting any strenuous exercise. This product may not be challenging or satisfying for all levels of exercise.

- **Turning the System ON & OFF:**
Position yourself to the side of the swimjet system. Use your free hand to press the System ON/OFF button.
- **Turning the Light ON & OFF:**
Position yourself to the side of the swimjet system. Use your free hand to press the Light ON/OFF button.
- **Adjusting the Water Flow:**
Holding onto the side of the pool, you can easily adjust the water flow coming from the jets. To do this simple turn the water volume control knob clockwise to reduce the flow. To increase the flow turn the knob counter clock wise.
- **Adjusting the air flow (or bubbles):**
The air regulator knob permits a controlled mixture of air into the water flow and creates a unique, invigorating, bubble effect. It will also add additional resistance to swim against. To do this simply turn the knob clockwise to reduce the air.

Getting Started

To start swimming, jogging or running it is suggested that the two nozzles are pointed slightly inward and slightly upward so that the water "breaks" approximately 4 ft. in front of the BaduJet super-sport (*See for Nozzle Adjustment*).

Start swimming with only minimal force in arms and legs until you feel yourself drifting backwards, then add force and swim upstream until a proper balance is found between force and endurance. Keep in mind that this unit is designed for a balanced workout. Find a pace that you can keep up for at least 20 minutes. Out pacing is always possible. The idea is to continue exercising for an extended period of time.

Getting Started - continued

NOTE: Under certain conditions it is possible that the current "drifts off" to the left or the right from the middle due to water bouncing off the back wall. In the event that it interferes with your swimming action, turn the unit OFF for a few minutes and restart.

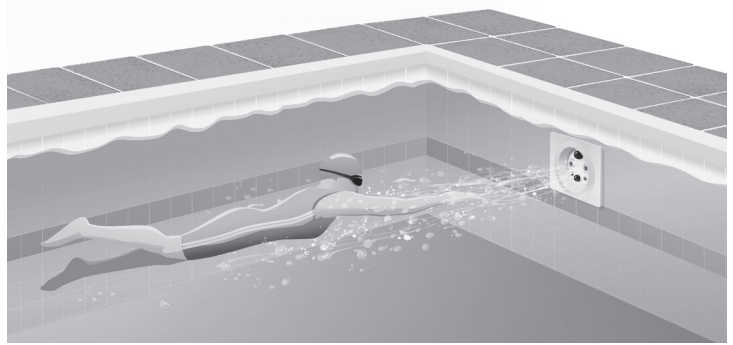

4 Service and Maintenance

Priming Pump

The BaduStream system comes with a 4 HP self-priming pump (Speck Model 21-80/33 GS) to specifically work with the swimjet system. The Model 21-80/33 GS self-priming pump has the ability to remove air from the plumbing lines when installed above the water level (up to 4 feet). During the initial startup, the pump must be filled with water. You should never run the pump dry for extended periods of time.

Before starting the pump for the first time (or after losing prime), remove the red filler plug. Fill the pump body with water (approx. 2 gallons) until the water is level with the suction inlet. Replace the red filler plug, hand tighten, making sure the o-ring is not damaged. Due to the large amount of air that can be trapped in the vertical portion of the suction line above the water level, initial priming time may be longer than with regular pool filtration pumps. It may take up to ten (10) minutes. This will not damage the mechanical seal. If prime is not achieved in ten (10) minutes, stop the pump, re-fill the pump body and restart.



Figure 2 - The Speck Model 21-80/33 GS (US Motor)

Control Box - Testing the GFCI

WARNING: Before each use, the GFCI located on the side of the control box ***must be tested.***

1. Press the RESET button on the GFCI. The GREEN "power" LED should be ON.
2. Press the TEST button: GREEN LED should turn OFF. RED LED should start blinking. Circuit breaker should trip to OFF position.
3. If sensing module LEDs **DO NOT** change or circuit breaker **DOES NOT** trip, **DO NOT USE THIS DEVICE**. Consult a qualified electrician for assistance.
4. Press RESET button: RED LED should turn OFF and GREEN LED should turn ON.
5. MANUALLY RESET circuit breaker to ON position to restore circuit power.



Figure 3 - Control Box

Nozzle Adjustments

When setting the nozzles for basic swimming, it is recommended that you set the nozzles in such a way that each nozzle intersects 4 feet away while breaking the surface at the same time. To help set the nozzles in position for best performance, please follow these instructions:

1. Parts required:

- Quantity 2 - 4' x 1.5" PVC Pipe
- Quantity 2 - 1.5" MPT x 1.5"/1.25" Hose Adapter
- Quantity 2 - Female Adapter 1.5" Slip x 1.5" FPT

2. Turn OFF the jet pump(s).

3. Insert each jet adjustment tool into jet nozzle.

4. Bring the ends of the adjustment tools together so they are touching in between the jet housings. Then raise the tools together so the ends touch the water surface. (See Figure 4)

5. Remove jet adjustment tool.

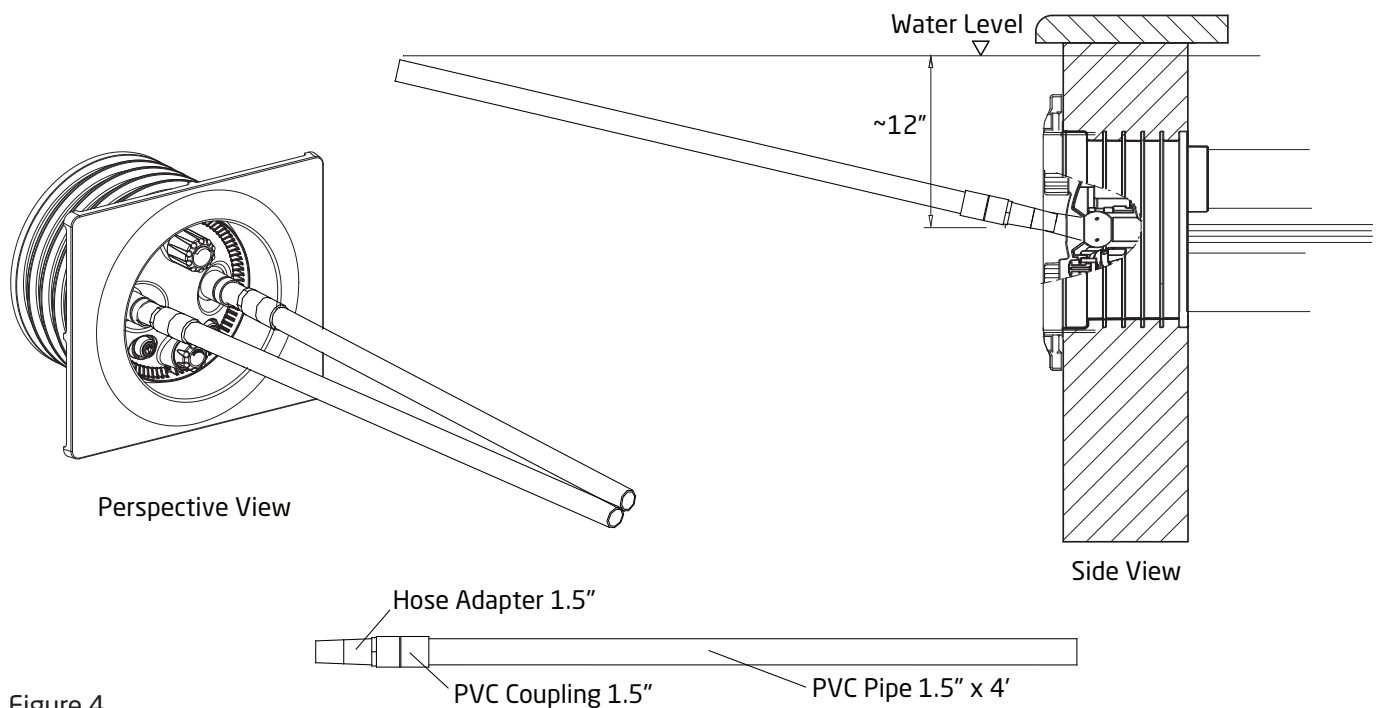

Figure 4
BaduJet Nozzle Adjustment

Winterizing

In areas subject to freezing water temperatures, you should protect your equipment. We recommend you purchase a winter cover kit part #2326000010K. This kit includes one (1) winter plate, one (1) gasket, four (4) M8 washers, and four (4) M8 x 30mm screws. (See Figure 5) Please contact your local pool professional for installation.

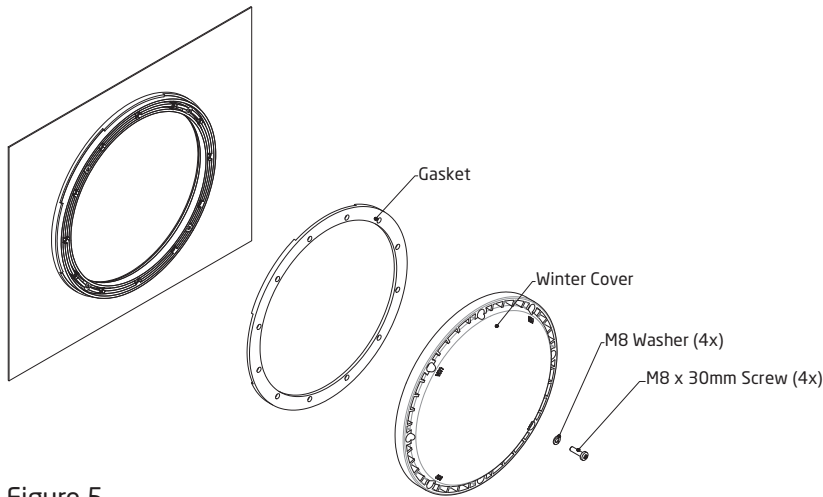

Figure 5
Winter Cover Kit

5 Frequently Asked Questions

Frequently Asked Questions

I can over swim the system, is there something I can do to help me from swimming through the system? Slow your pace down until you found the stroke that will prevent you from out swimming the system. Depending on the size of the pool you could drift back and swim into the stream and try to find the “sweet spot” which is about 4’ from the jets.

How can I use the system for my kids? Our BADU swim jets systems will add fun and enjoyment for all ages. The kids can boogie broad against the current. Kids can play in front of the current. To do this turn the air up and just the adjust nozzles upwards to create a choppy white water effect.

What is a self-priming pump?

A self-priming pump has the ability to remove air from the plumbing lines when installed above water level (up to 4 feet). During the initial startup, the pump must be filled with water. You should never run the pump dry.

Why must a self-priming pump first be filled with water?

A self-priming pump must have a sufficient amount of water in the pump housing. Only then can air be removed from the suction line. It is necessary to fill your pump up to the suction connection with water. If you do not fill the pump with water you may damage the mechanical seal in the pump.

What are the maintenance requirements for the pump?

The Speck Model 21-80/33 GS pumps are generally maintenance free. From time to time you should carry out a visual inspection. Check to see if pump is leaking, a few drops is normal. Remove any debris around the pump.

Does the LED light come in different colors?

Yes. The LED light comes in blue or a multi-color option.

How many amps does the pump operate at?

4.0 HP: Maximum 21.0 - 19.4 Amps @ 208-230 V

Frequently Asked Questions

What size breaker do I need?

You must use a 40 amp breaker for the 4 HP pump to avoid nuisance tripping.

Should the swimjet system be tied into the filter system?

No. The swim jet system and the filter system should not be plumbed together as they each provide very specific functions.

Can I use it with automated controls?

Yes. It comes with the ability to tie into automated control systems or other switching devices. A licensed electrician would need to wire in this feature.

How should I store my pump for the winter season?

It's simple: drain pump and store it in a warm and dry place.

Why is the swimjet pushing to the side?

Refer to nozzle adjustment section. Also, Speck Pumps offers a BADU Swim Mirror that will help you stay in the swim lane. You will be able to see yourself as you swim.

My pool is the recommended size but my feet keep hitting the wall, what can I do to fix that?

Adjust the flow so the system is not pushing you back. Another option is the BADU Swim mirror. This will help keep you in the swim lane.

Trouble Shooting

PROBLEM	POSSIBLE CAUSES	SOLUTION
1. Pump will not prime.	a. Suction air leak. b. No water in pump. c. Closed valves or blocked lines. d. Low voltage to motor.	Make sure the red filler plug and o-ring are clean and properly positioned. Tighten red filler plug. Tighten all pipes and fittings on suction side of the pump. Be sure water in the pool is high enough to flow through the jet housing. Make sure pump housing is full of water. Open all valves in system. Open pump and check for clogging of impeller. Check voltage at motor. If low, pump will not come up to speed.
2. Motor does not turn.	a. No power to motor. b. Pump jammed.	Check that all power switches are on. Be sure fuse or circuit breaker is properly set. Check motor wiring at terminals. With power off, turn shaft. It should spin freely. If not, disassemble and repair.
3. Low flow.	a. No water in pump. b. Closed valves or blocked lines. c. Low voltage to motor	See problem 1.
4. Noisy operation of motor.	a. Bad bearings.	Check for noise when shaft is turned by hand. Motor will be very hot in bearing area when running. Replace bearing.

Trouble Shooting - continued

PROBLEM	POSSIBLE CAUSES	SOLUTION
5. Motor runs hot.	These motors will run hot to the touch, however, this is normal. They are designed that way. Thermal overload protector will function to turn them off if there is an overload or high temperature problem. Excessive heat can be caused by:	
	a. Low voltage.	Increase size of electrical wire. Be sure motor is operating on correct voltage.
	b. Installed in direct sun.	Shield motor from sun's rays.
	c. Poor ventilation.	DO NOT block motor ventilation openings.
6. Noisy operation of pump.	a. Air leak in suction line.	Repair leak. Check suction pipe, red filler plug, and o-ring (See Problem 1).
	b. Restricted suction line due to blockage or under size pipe. Indicated by high vacuum reading at pump suction.	Remove blockage or increase suction pipe size. Are all suction valves fully open?
	c. Foreign matter (gravel, metal, etc.) in pump impeller.	Disassemble pump and remove foreign matter from impeller.
	d. Cavitation.	Improve suction conditions. (Reduce suction line length, reduce number of fittings, increase pipe size.)
7. Motor overload protection "kicks out".	a. Motor is not connected properly.	Check wiring diagram on motor.
	b. Low voltage due to under size wire or low incoming voltage.	Check with volt meter. Increase size of supply wire. Report low supply voltage to power company. Voltage at motor must be within 10% of motor nameplate voltage.
	c. Wrong size heaters in protective device.	Heaters should be one size larger than full load amps shown on motor nameplate.
	d. Overload due to binding in pump or wrong size impeller.	Indicated by high amperage readings on motor, binding shaft. Disassemble unit and correct.
8. The LED light is not working?	a. Moisture in air tubing or bad air button.	Remove air tubing from air switch at control box. Connect a short piece of air tubing to the LED air switch. Blow into tube and check if LED turns ON/OFF.
	b. Control Box.	Contact certified electrician to diagnose control box components.
9. The volume control knob keeps spinning?	a. Broken Spindle.	Contact your pool service company or call 800-223-8538.
10. My ON/OFF air button is not working properly?	a. Control Box.	Check GFCI. If green LED does not stay ON, contact a certified electrician to diagnose control box components.
	b. Air tubing.	Check air tubing connection on the control box. Check that the tubing is not bent or pinched. Tubing may need to be replaced.
11. The system will not turn OFF?	a. Control Box Components.	Press TEST button on the control box GFCI to turn off system. Contact a certified electrician to diagnose control box components.

Trouble Shooting - continued

PROBLEM	POSSIBLE CAUSES	SOLUTION
12. I have the volume control knob turned completely up but the flow is weak?	a. Debris in pump casing/impeller. b. Improper swim jet assembly.	Contact your local pool service company to check inside pump casing for any debris. The internals may need to be removed for inspection of the spindle.
13. My plastic cover is cracked.		Contact your pool service company or call 800-223-8538.
14. The massage hose is stuck against the jet		Apply both hands on the outer side of the lip of the locking ring, slightly pulling back until this snaps back. Should be able to remove

6 Product Specification

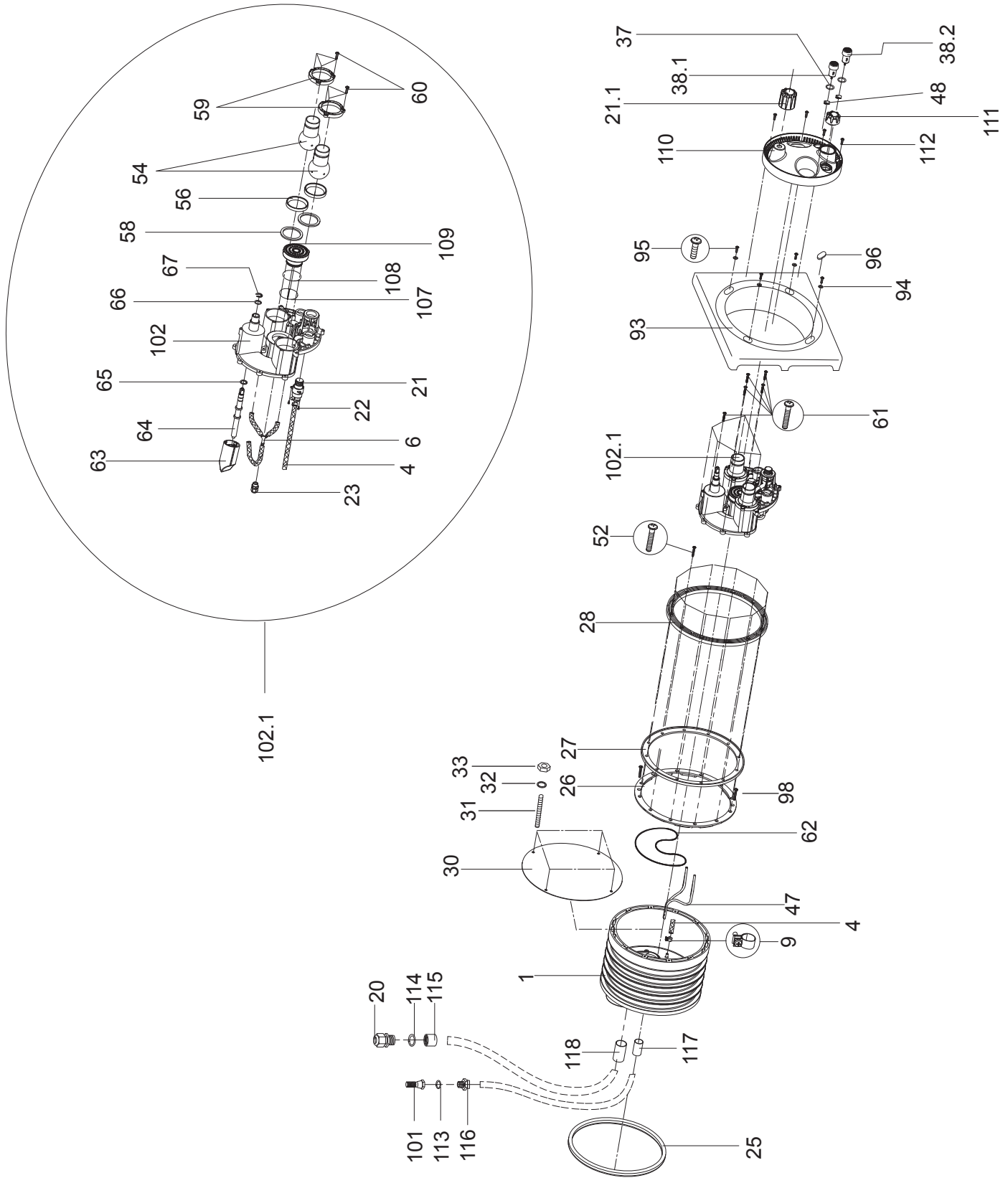

Exploded View

PART NUMBER	DRAWING NUMBER	QTY REQUIRED	DESCRIPTION
2326000002	1	1	JET HOUSING
2301001007	4	3 FT	HOSE - AIR REGULATOR 8 x 3mm (PRICE PER FOOT)
2326000408	6	1	HOSE (3X) WITH Y- HOSE BARB
2301001008	9	2	CLAMP - HOSE, AIR REGULATOR 14/9 SS A4
2326000031	20	1	STRAIN RELIEF - LIGHT CABLE, 3/4" NPT
2321000409	21	1	AIR REGULATOR COMPLETE
2326000006	21.1	1	VOLUME CONTROL KNOB
5879812996	22	3	SCREW - AIR REGULATOR, 2.9 x 9.5
5882501619	23	1	STRAIN RELIEF - LIGHT CABLE, M16 x 1.5
2326000020	25	1	ROUND SEALING CORD
2301000026	26	1	GASKET WITH KNOBS - JET HOUSING
2326000021	27	1	GASKET - CLAMPING RING
2301000028	28	1	RING - CLAMPING
2301000030	30	1	GUNITE COVER
5805510880	31	4	STUD - GUNITE COVER M8 x 80mm
5809021080	32	4	WASHER - GUNITE COVER M8
5879340800	33	4	NUT - STUD - GUNITE COVER M8 A2
2326000014	37	2	O-RING PNEUMATIC BUTTONS 24 x 3mm
2321000401	38.1	1	PNEUMATIC BUTTON COMPLETE - PUMP
2321000404	38.2	1	PNEUMATIC BUTTON COMPLETE - LIGHTS
2300202060	47	2	AIR TUBING - LIGHT/PUMP 4 x 1.5mm (PRICE PER 10M)
2302001046	48	2	CLAMP - HOSE, PNEUMATIC BUTTON 6.8 - 8mm
5879860830	52	12	SCREW - CLAMPING RING, POZIDRIV/PAN M8 x 30mm A4
2302002954	54	2	NOZZLE - 40mm
2302002056	56	2	SEAT - NOZZLE
2302002057	58	2	SPACER - NOZZLE 6.2mm
2319800817	59	2	NOZZLE FLANGE
5879006023	60	6	TAPPING SCREW - BALL NOZZLE FLANGE, 6 x 22mm A4
5879006023	61	10	TAPPING SCREW - NOZZLE HOUSING, 6 x 22mm A4
2326000013	62	1	O-RING - NOZZLE HOUSING 257 x 3mm
2326000004	63	1	VOLUME CONTROL CYLINDER
2303002964	64	1	VOLUME CONTROL SPINDLE (COMPLETE)
2326000026	65	1	O-RING 15 x 4mm - SPINDLE
2302002065	66	2	WASHER - VOLUME CONTROL SPINDLE, 23 x 16.2 x1.5mm
2302002067	67	1	RETAINER - SHAFT, VOLUME CONTROL SPINDLE
2302005236	93	1	COVER - RECTANGULAR
5871250800	94	4	WASHER - RECTANGULAR COVER 8.4mm A4
5879860820	95	4	BOLT - RECTANGULAR COVER, PHILLIPS M8 x 20mm
5879860880	95.1	4	BOLT - RECTANGULAR COVER, PHILLIPS M8 x 80mm
2302005237	96	4	PLUG - RECTANGULAR COVER
2991000140	98	2	SCREW - COUNTERSUNK PHILLIPS M8 x 30mm
5030000105	101	1	VALVE - CHECK 1/2"
2326000003	102	1	HOUSING - NOZZLE
2326000402	102.1	1	HOUSING - NOZZLE COMPLETE
3932541201	107	1	O-RING - LIGHT 48 x 2mm
2607101019	108	1	O-RING - LIGHT 49 x 3.5mm
2326000037	109	1	LIGHT LED 12V AC - WHITE, 10M
2326000005	110	1	LIGHT COVER
2321000022	111	4	AIR REGULATOR KNOB
5879006023	112	1	TAPPING SCREW - LIGHT COVER, 6 x 22mm A4
2920141230	113	1	O-RING - CHECK VALVE, 19 X 3mm
2326000032	114	1	O-RING - STRAIN RELIEF
2326000034	115	1	ADAPTOR - STRAIN RELIEF, FEMALE, PVC 3/4"
2301001030	116	1	ADAPTOR - CHECK VALVE, MALE, PVC 1/2"
5862432021	117	1	CONNECTOR - AIR REGULATION LINE M20 x 1/2"
5862432531	118	1	CONNECTOR - CONDUIT M25 x 3/4"
2920280729	NOT SHOWN	1	CONTROL BOX BJC-7-GFCI+CP SSII

OPTIONAL PARTS

2326000036	109.1	1	LIGHT LED 12V AC - MULTICOLOR, 10M
2326000038	109.2	1	LIGHT LED 12V AC - BLUE, 10M
2326000010K	NOT SHOWN	1	WINTER COVER KIT
2300003000	NOT SHOWN	1	MASSAGE HOSE 5 FT. WITH PULSATOR
2300003006	NOT SHOWN	1	MASSAGE HOSE 15 FT. WITH PULSATOR
2300022000	NOT SHOWN	1	CAP - NOZZLE, CLOSE OFF

7 Limited Warranty

Speck Pumps-Pool Products, Inc. grants solely to the original consumer purchaser ("Buyer") of the Badu® SwimJet System(s) the following personal, non-transferable and limited warranty on the following terms and conditions (the "Limited Warranty"): the Badu SwimJet System(s) is warranted to be free of material defects in materials or workmanship under normal use for a period of one (1) year beginning on the date of the Buyer's purchase of the Badu SwimJet System(s) (the "Limited Warranty Period"). Notwithstanding any provisions herein to the contrary, the warranties and obligations hereunder shall not in any event extend for more than two (2) years beyond the date of shipment of the Badu SwimJet System(s) from the factory (the "Limited Warranty Period"). The Limited Warranty is subject to each of the following additional terms and conditions:

1. IN THE EVENT OF ANY BREACH OF THE LIMITED WARRANTY, SPECK PUMPS-POOL PRODUCTS, INC.'S ENTIRE OBLIGATION AND LIABILITY TO BUYER, AND BUYER'S SOLE AND EXCLUSIVE REMEDY SHALL BE AS FOLLOWS:

Speck Pumps-Pool Products, Inc. will, at its option, either repair or replace the Badu SwimJet System(s) or refund to Buyer the purchase price actually paid by Buyer for the Badu SwimJet System(s) subject to the Limited Warranty. Speck Pumps-Pool Products, Inc. shall have no obligations under the Limited Warranty unless Buyer delivers timely written notice to Speck Pumps-Pool Products, Inc. of the Limited Warranty claim within the Limited Warranty Period and returns the Badu SwimJet System(s) to Speck Pumps-Pool Products, Inc. if requested. To the fullest extent permitted by law, Speck Pumps-Pool Products, Inc. expressly disclaims any liability for, and the Limited Warranty does not include or cover, any labor, costs or other expenses in connection with the removal, transportation, shipment, insurance, replacement, repair, or installation of repaired or replaced parts or for any other costs or expenses or damages to property or things including, but not limited to, those arising in connection with the use of, or inability to use, the Badu SwimJet System(s).

2. To the fullest extent permitted by law, the Limited Warranty will be void and of no force or effect and Speck Pumps-Pool Products, Inc. will have no liability, responsibilities or obligations to Buyer or with respect to the Badu SwimJet System(s) in the event of the occurrence of any one or more of the following:

- (a) Any damage to the Badu SwimJet System(s) caused by Buyer, any third party, ground movement, other natural forces, acts of God or any other sources or causes not arising from a breach of the Limited Warranty, excluding ordinary wear and tear;
- (b) Any replacement, modification, alteration or repair of any parts or components of the Badu SwimJet System(s) by anyone other than Speck Pumps-Pool Products, Inc.;
- (c) Any abuse, misuse, accident, tampering with, improper installation or modification of the Badu SwimJet System(s) or any other actions, inactions or failures to act that violate the terms and conditions of this Limited Warranty;
- (d) Buyer's failure or inability to present an invoice, bill, receipt or other documentation clearly evidencing that the Badu SwimJet System(s) was installed and maintained in strict compliance with this Limited Warranty and that the claim was timely submitted within the Limited Warranty Period; and/or
- (e) Buyer's failure to comply with the conditions and contingencies set forth in paragraph 3 below.

3. The Limited Warranty is expressly conditioned and contingent upon Buyer's strict compliance with each of the following:

- (a) Installation of the Badu SwimJet System(s) by an experienced and qualified pool industry professional and a licensed electrician who is licensed within the jurisdiction in which the Badu SwimJet System(s) is installed and will be used; and
- (b) Buyer's operation and maintenance of the Badu SwimJet System(s) in strict accordance with Speck Pumps-Pool Products, Inc.'s printed operator/maintenance manuals delivered with the Badu SwimJet System(s).

4. DISCLAIMER: THE LIMITED WARRANTY IS THE ONLY WARRANTY MADE AND IS IN LIEU OF ALL OTHER WARRANTIES, AND ANY AND ALL IMPLIED WARRANTY OR CONDITION OF MERCHANTABILITY, THE IMPLIED WARRANTY AGAINST INFRINGEMENT, AND THE IMPLIED WARRANTY OR CONDITION OF FITNESS FOR A PARTICULAR PURPOSE ARE EXPRESSLY LIMITED IN THEIR SCOPE AND DURATION TO THE ONE YEAR TERM OF THE LIMITED WARRANTY SET FORTH HEREIN. SOME STATES DO NOT ALLOW LIMITATIONS ON HOW LONG AN IMPLIED WARRANTY LASTS, SO THE ABOVE LIMITATION MAY NOT APPLY TO THE BUYER.

Limited Warranty - continued

5. TO THE FULLEST EXTENT PERMITTED BY LAW, IN NO EVENT SHALL SPECK PUMPS-POOL PRODUCTS, INC. OR ITS OFFICERS, DIRECTORS, EMPLOYEES, SHAREHOLDERS, AGENTS, OR REPRESENTATIVES BE LIABLE FOR ANY SPECIAL, INDIRECT, INCIDENTAL, EXEMPLARY OR CONSEQUENTIAL DAMAGES OR LOSS, INCLUDING TIME, MONEY, GOODWILL, AND LOST PROFITS IN ANY WAY WHICH MAY ARISE HEREUNDER OR FROM THE USE OF OR INABILITY TO USE THE BADU SWIMJET SYSTEM(S) OR THE PERFORMANCE OR NONPERFORMANCE OF ANY OBLIGATION UNDER THIS LIMITED WARRANTY. THIS PARAGRAPH, THE WARRANTY DISCLAIMERS IN PARAGRAPH 4 ABOVE, AND THE SOLE AND EXCLUSIVE REMEDY SET FORTH IN PARAGRAPH 1 ABOVE SHALL APPLY EVEN IF SPECK PUMPS-POOL PRODUCTS, INC. HAS BEEN NOTIFIED OF THE POSSIBILITY OR LIKELIHOOD OF SUCH DAMAGES OCCURRING, WHETHER SUCH LIABILITY IS BASED ON CONTRACT, TORT, NEGLIGENCE, STRICT LIABILITY, PRODUCTS LIABILITY OR OTHERWISE, AND EVEN IF ANY REMEDY STATED HEREIN FAILS OF ITS ESSENTIAL PURPOSE. SOME STATES DO NOT ALLOW THE EXCLUSION OR LIMITATION OF SPECIAL, INDIRECT, INCIDENTAL, EXEMPLARY OR CONSEQUENTIAL DAMAGES OR LOSS, SO THE ABOVE EXCLUSIONS AND LIMITATIONS MAY NOT APPLY.

6. This Limited Warranty gives the Buyer specific legal rights, and the Buyer may also have other rights, which vary from state to state.

7. A return merchandise authorization ("RMA") must be obtained from Speck Pumps-Pool Products, Inc. before returning any product. Products returned without an RMA will be refused and returned, unopened, to the Buyer. All returned products are to be sent freight prepaid and insured for Buyer's protection to the manufacturer at 8125 Bayberry Road, Jacksonville, Florida 32256 USA. Under no condition will products be accepted after the expiration of the Limited Warranty Period. Speck Pumps-Pool Products, Inc. shall not bear any costs or risks incurred by Buyer in shipping a defective Badu SwimJet System(s) to Speck Pumps-Pool Products, Inc. or in shipping a repaired or replaced Badu SwimJet System(s) to Buyer.

