



MICROWELL



**WALL-MOUNTED SWIMMING POOL DEHUMIDIFIER
USER'S MANUAL**

MODEL: DRY 300/400/500 PLASTIK

Thank you for your decision to purchase our device.

Please read this user manual carefully before switching on the device.

Please keep the instructions in this practical guide for your quick know-how.

We do not take responsibility or warranty in case of damage, loss or impairment caused by incorrect usage, or by usage for other purposes not described in this manual.

- Contents:
1. Safety measures
 2. Specifications for use
 3. Instructions for use
 4. Instructions for maintenance
 5. Servicing the unit
 6. Installation guide
 7. Technical data

1. SAFETY MEASURES

- Do not manipulate with the device with wet hands.
- Do not spray any flammable substances into the equipment; this might lead to fire.
- Do not clean the device with water.
- Do not clean the equipment with aggressive cleaning agents, this might lead to damage or deformations.
- When cleaning plastic parts do not use any cleaning agents unsuitable for the cover of the dehumidifier (household cleaning agents, solvents, bleaching agents, benzene, diluents, rough cleaning powder, cresol, chemical agents). Instead, sweep the dehumidifier cover with a soft cloth or a sponge.
- Never throw or insert any objects into any hose or opening.
- The cover is made of plastic. Do not manipulate with lighted cigarette, cigarette ashes, or any other kind of fire in vicinity to this part.
- Use this device exclusively for the intended purpose, as described in the attached instruction manual. Do not use parts which are not recommended.
- Never block the air opening of the product. Protect the air openings from clogging by particles, hair etc.
- When the device is not running correctly (smoke, smell etc.), shut down the device by a circuit breaker in the switchboard.
- Repair and dislocation must be performed exclusively by a service technician.
- Before cleaning the device, switch off the circuit breaker in the switchboard.
- Do not place any objects onto the device.
- When you do not intend to use the device for a longer time, switch off the circuit breaker.

2. SPECIFICATIONS FOR USE

The units are designed especially for use in indoor swimming pools, spas and saunas. They can also be very useful in laundries, drying rooms and elsewhere.

The Microwell DRY 300 PLASTIK is designed for halls with a swimming pool surface area of up to 30 m².

Microwell DRY 400 PLASTIK is designed for rooms with a swimming pool, which surface is up to 45 m².

The Microwell DRY 500 PLASTIK is designed for halls with a swimming pool surface area of up to 60 m².

The condition for using the unit is maintaining the room temperature within the range between a minimum of 22°C and a maximum of 35°C. Ideally, the air in the room should be 2-3 °C warmer than the water in the swimming pool.

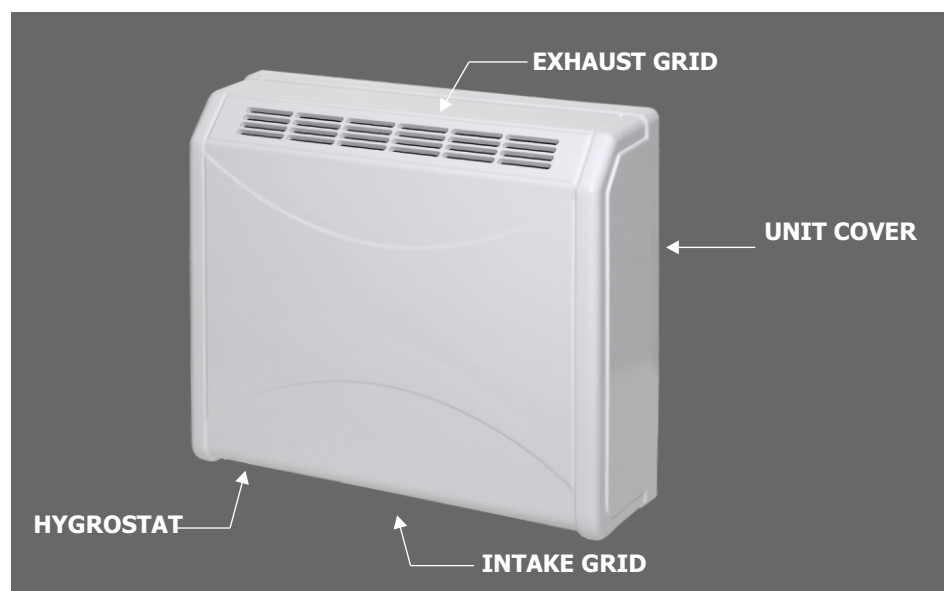

3. INSTRUCTIONS FOR USE

3.1. Humidity control by means of the built-in humidistat

The built-in humidistat is located at the bottom of the unit, on the left. The built-in hygrometer reads the humidity of the incoming air and, depending on the set value, does or does not switch the compressor on. In the central position of the regulator, the unit secures the average relative humidity of 60%. In indoor swimming pool halls, the correct air humidity should range from 55 to 65%. Decreasing the humidity under this range is not desirable either from the physiological viewpoint or from the viewpoint of protection of the building. Moreover, it increases the electricity consumption. The humidistat can be controlled by the user.



A view at the hygrometer scale

3.2. Remote control

On demand a dehumidifier can be controlled by remote humidistat & thermostat DRY EASY 300. If so, User's manual is attached to this Manual.



3.3. Control of the fan

Under the inside cover of the unit, there is a two-position fan mode switch. In the first position, the fan runs even if the compressor of the appliance has stopped: continuous operation of the fan. In the second position, the fan only runs simultaneously with the compressor: periodical duty of the fan. The continuous operation mode of the fan is preferable, since the humidity reader built in the device continuously reads humidity, and therefore a greater accuracy is reached. At the same time, continuous operation of the fan results in better air circulation in the room. The installation work supplier selects the mode of the fan according to the request of the user.

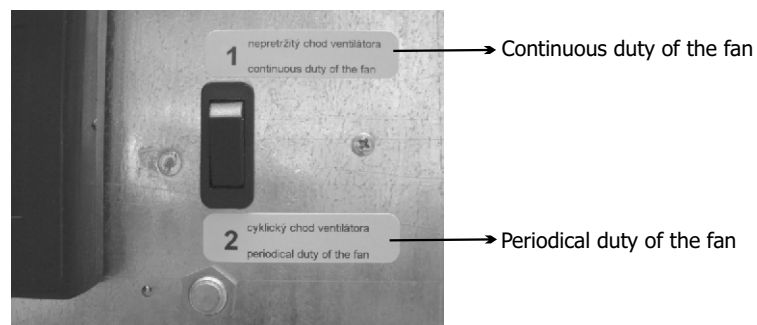

Switch of the fan operation

3.3. Control of the fan

Under the inside cover of the unit, there is a two-position fan mode switch. In the first position, the fan runs even if the compressor of the appliance has stopped: continuous operation of the fan. In the second position, the fan only runs simultaneously with the compressor: periodical duty of the fan. The continuous operation mode of the fan is preferable, since the humidity reader built in the device continuously reads humidity, and therefore a greater accuracy is reached. At the same time, continuous operation of the fan results in better air circulation in the room. The installation work supplier selects the mode of the fan according to the request of the user.

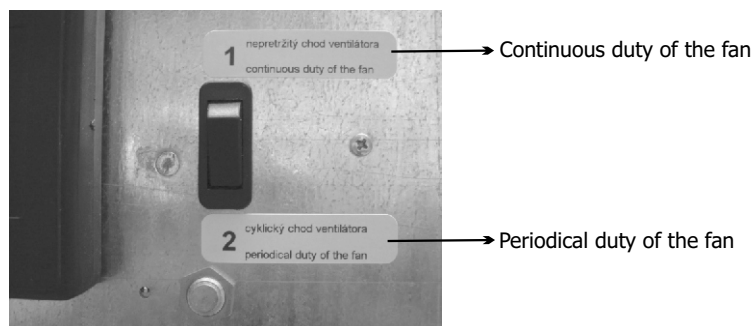

Switch of the fan operation

3.4. Control of the compressor

Start-up of the compressor is, due to its protection, delayed by 3 minutes. Depending on the humidity of the environment, it may take even longer for compressor to start operating. Once the compressor stops operating, the operation is renewed automatically, at the earliest after three minutes. The user must not handle the setting element of the delay-action relay.

4. MAINTENANCE INSTRUCTIONS

It is necessary to make sure that the suction inlet and the exhaust outlet are not covered. It is forbidden to place towels or clothing items onto the exhaust outlets to dry them. The unit's cover can be cleaned with standard cleaning agents using a soft cloth or a sponge. If water dripping out of the unit, please check the condensed water drain and make sure the pipe is not obstructed.

5. SERVICING THE UNIT

At least once a year, it is necessary to have the unit checked and cleaned by a service specialist. This is inevitable to secure a long service life of the unit. We do not recommend the user to clean the interior elements of the unit, as this might cause a damage to the unit. The unit contains mobile elements and live elements, therefore the interior parts may only be cleaned by a certified electrician trained to service refrigerating appliances.

6. INSTALLATION GUIDE

The unit must be installed in compliance with the local installation and electrical installation regulations !

6.1. Location of the unit

The unit is to be installed on the wall or on the mobile stand. To ensure the right operations of the dehumidifier and its maximum efficiency in terms of humidity control, it is necessary to ensure proper air circulation into and from the dehumidifier. This requires the actual unit placement appropriately into the swimming pool hall respecting basic prerequisites of air circulation and air flow. It is strictly forbidden to install the unit just below the ceiling. At least 200mm of a free space must be kept above the unit and at least 150mm below the unit. Each swimming pool hall is individual thus a special care needs to be taken to choose a proper dehumidifier placement. It is forbidden to install the unit on the ground. It is also strictly forbidden to block the air inlet and outlet with any objects (canoe, buckets, ceiling beams, etc.). For maintenance purposes please keep free space of 200mm on both sides of the dehumidifier.

6.2. Mounting the unit

The units have a self-supporting structure and are remarkably easy to install.

A part of the unit accessories is also an installation bracket, which must be fixed onto the wall. The axis of the fixation openings is 210 mm lower than the top edge of the unit. The fixation openings are 420 mm apart (DRY 300/400 PLASTIK) or 360 mm apart (DRY 500 PLASTIK). Once the bracket is mounted to the wall, it is possible to mount the unit without disassembling its cover.

Model DRY 300/400 PLASTIK

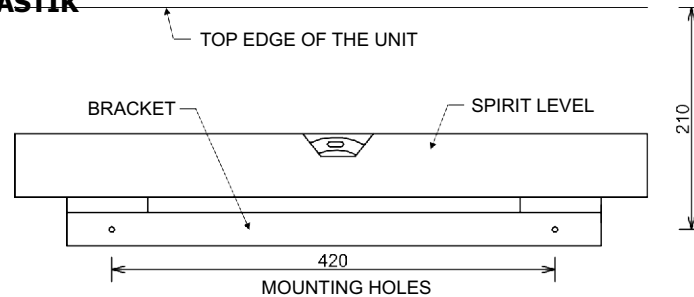

Model DRY 500 PLASTIK

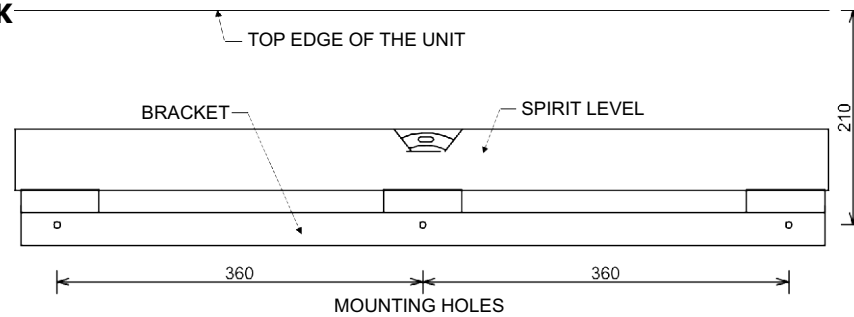

6.3. Dismounting and mounting the cover

The cover can be dismounted after releasing two screws (DRY 300/400) or three screws (DRY 500) at the bottom of the unit. Release the screws, pull the bottom part of the cover toward yourself and then, by lifting it shortly, rake down the cover from the rear plate. To mount the cover, carry the procedure out in reverse order.

6.4. Securing the position of the unit

The unit is designed in such a way that it can be securely mounted and will hold in its place even if lifted accidentally. In the top edges of the back plate, there are screw holes for safety screws, which are accessible after dismounting the front fibreglass cover. Arrows indicate the safety screw holes in the back plate. A safety screw is fastened through a screw hole in the back plate into a wall plug in the wall. This will prevent the unit from being accidentally pulled out and falling off the mounting bracket. At the same time, it will secure the perpendicular position of the unit and align the unit with the wall.

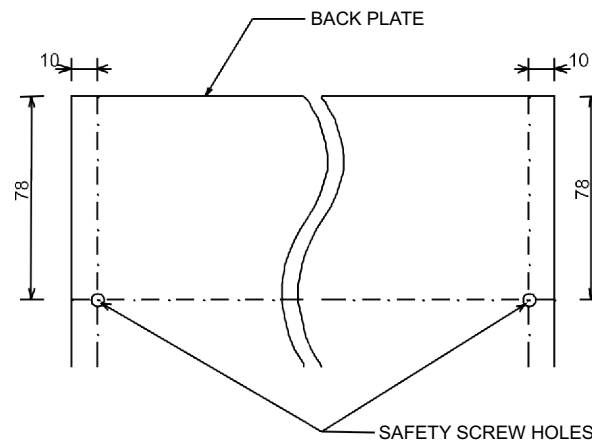

6.5. Drainage of condensate

Condensed water is drained from the unit by the force of gravity. It is necessary to situate the unit in such a way that there is sufficient declivity for the drainage of condensed water. The condensation product must be drained through a siphon into a sewer or into the outside environment. It is strictly forbidden to drain the condensed water back into the swimming pool, as it may be polluted by bacteria. A pipe for condensate drainage is led out at the bottom of the unit, on the left. This pipe is to be inserted into a sewerage pipe with the inside diameter of at least 18 mm.

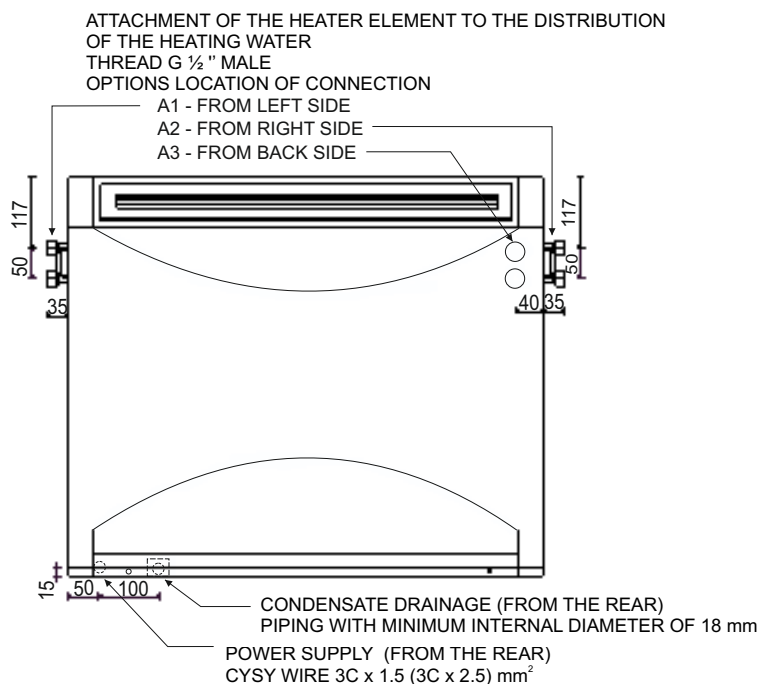

CONNECTIONS ARE VALID FOR MODELS DRY 300/400 PLASTIK AS WELL DRY 500 PLASTIK - FRONT VIEW

6.6 Connection of the unit onto the mains

Connection of the unit onto the mains must conform to relevant safety standards. Connection requirements: Power supply: 220-240V / 50Hz. Protection: 10A (DRY 300/400 PLASTIK) or 16A (DRY 500 PLASTIK) by a protective switch with nominal differential drop-out current not exceeding 30 mA. The unit's terminal board for connection onto the electric mains is situated on the left hand-side of the unit. The main switch of the unit must be situated outside of the swimming pool hall. The main switch of the unit must be bipolar, with switch-out breaking of conductors L and N. An appliance for disconnecting the unit from the mains must be embedded into a firm surface. The distance of contacts, when switched off, must be at least 3 mm for all poles. The connection of the appliance to the electric mains must be carried out by a certified electrician.

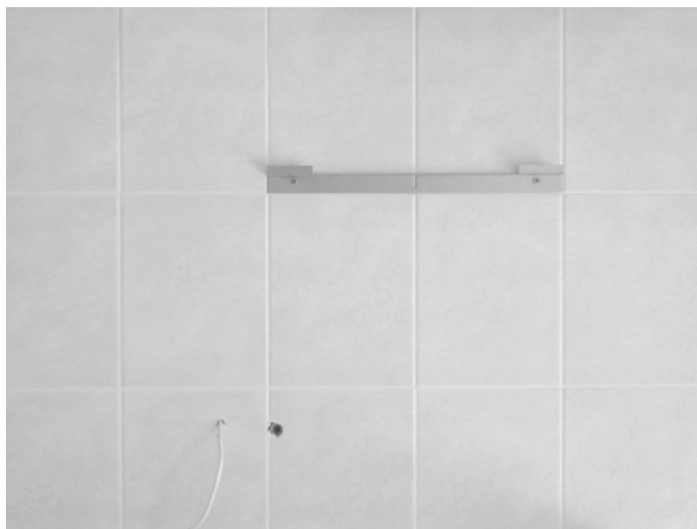

An example of preparation of electric power supply, condensate drainage and mounting of the bracket

LOCATION OF THE EQUIPMENT

The location must be in compliance with the HD 384.7.702 S1, IEC 60364-7-702 standard.

It is recommended to situate the unit outside zones 0, 1 and 2.

In case the unit is situated into zones 2 or 1, it must be adhered to the HD, IEC standard.

ZONE 1, IPX4

Swimming pools which are not cleaned by jet water

in the distance of 1250 to 2000 mm from the swimming pool edge, the unit must adhere to the HD, IEC standard and in the height of at least 300 mm from the floor

ZONE 2, IPX2

Swimming pools which are not cleaned by jet water

In the distance of 2000 to 3500 mm from the swimming pool edge, the unit must adhere to the HD, IEC standard and a minimum 150 mm elevation above the ground is required for sufficient air flow. Installing the unit on the floor is prohibited.

OUTSIDE THE ZONES

In the distance of 1250 mm or less from the swimming pool edge, the bottom edge of the unit must be be in the height of 2500 mm from the swimming pool surface; if it is embedded under the floor, then 2500 mm from the floor.

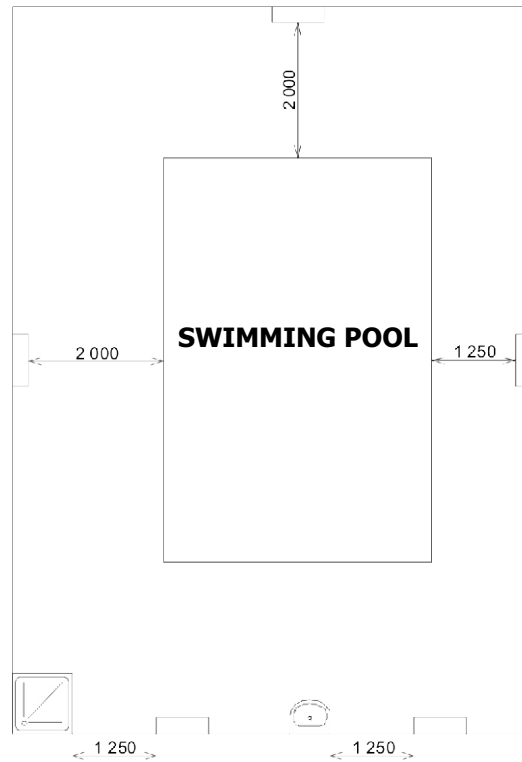

At least 1250 mm (i.e. out of the reach of the hand) from the lateral edge of the shower cabinet. It cannot be placed above the shower cabinet.

At least 1250 mm (i.e. out of the reach of the hand) from the lateral edge of the wash basin, in the minimum height of 1200 mm above ground. It cannot be placed above the wash basin.

OUTSIDE THE ZONES

In the distance of at least 1500 mm from the vertical plane around the jumping platforms, diving boards and 2500 mm above the highest surface, where persons are likely to stay.

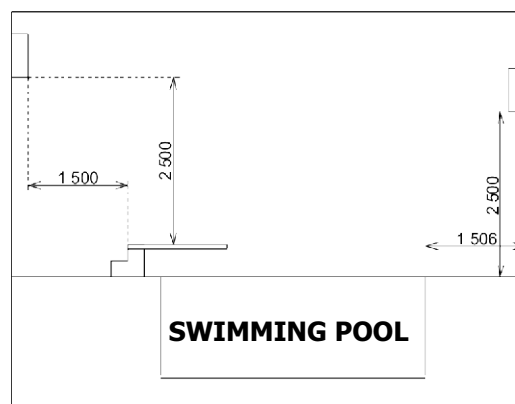

OUTSIDE THE ZONES

If the unit is in the distance of less or equal to 1250 mm horizontally from the edge of the swimming pool, then it must be raised up to the height of 2500 mm from the swimming pool surface; if the pool is embedded under the floor, then the unit must be raised up to the height of 2500 mm from the floor.

It is inevitable to locate the unit outside the zones, where cleaning by jet water is supposed. Connection of the unit to the mains and its protection must correspond with the applicable standards. Electrical supply of the unit must be carried out by a protective isolating transformer or it must be protected by a current protective switch with a nominal differential cut-off current not exceeding 30 mA.

6.7. LPHW heater element - to order

The LPHW heater elements are supplied only to order. Connection of the hot water heater element onto the LPHW plumbing is carried out similarly to the installation of radiators. On the feeder pipe, it is connected by a control valve and on the return pipe by a closing screw joint. The LPHW is not supplied with a control valve and a screw joint; these are supplied by the supplier of the heating.



Attachment threading of the hot water heating element

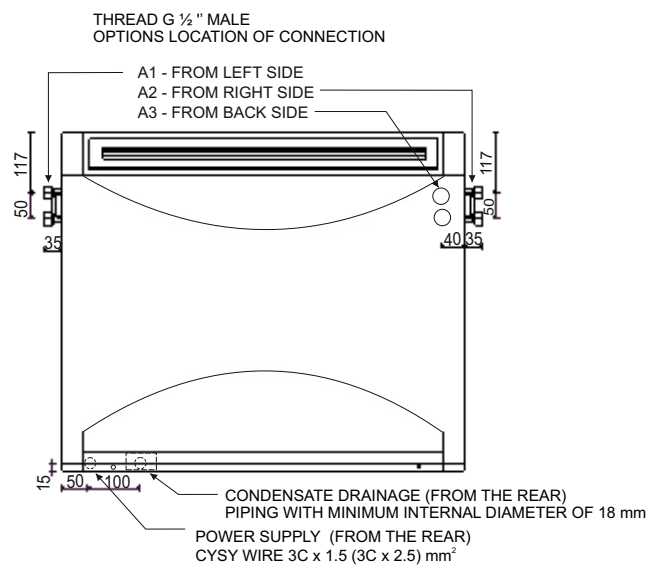

Attachment of the heater element to the distribution of the heating water

After installing the LPHW plumbing and leading the LPHW into the element under pressure, it is necessary to bleed the heater element. The bleeding valve is located on the feeder pipe of the LPHW heater element. To secure that the LPHW heater element works always at full heat output, blowing onto the unit by a fan must be provided even when no dehumidification is being performed. Therefore, when using the LPHW heater element, the switch of fan operation must be switched into the position of continuous operation.

6.8. Hot gas defrost - on demand

Hot gas defrost allows the dehumidifier to operate effectively at air temperatures down to 5°C. The gas circuit is equipped with 4-way valve. When temperature on evaporator drops below zero, system starts to count 30 minutes of time. After this period the evaporator temperature is checked again and if the current temperature is still below zero, a compressor and a ventilator are turned off. Gas circuit is reversed and after 3 min a compressor starts. System now defreezes the unit for 3 minutes. After another 3 minutes, if the defrost cycle is completed, the unit goes into usual operations. In extremely low temperatures and in still humid enough air it is normal to take 2 or 3 defreezing cycles to complete the procedure.

NOTE: It is normal for a compressor to turn itself off and on again during defreezing cycle.

6.9. Mounting behind the wall - on demand

The dehumidifiers are simply adapted also to installation behind the wall into the adjacent room. In such case, only two grids are visible in the swimming pool area. These are the same grids which are, in the basic configuration, installed on the dehumidifier's cover. In the configuration for installation behind the wall, conduit adapters are screwed onto the dehumidifier's cover. The adapters are delivered for passage through the wall of the length of 400 mm. In the place of installation, they are shortened from the side of the swimming pool as necessary.



View from the adjacent room



View from the swimming pool hall

6.10. Compressor transport protection (DRY 500 PLASTIK only)

Your compressor is protected for the transport with plastic zipper strap. Due to compressor size and weight this is necessary in order to have a fully functional unit delivered to you safely. This protection must be removed before starting the unit. Please view below pictures on how to proceed. The procedure generally takes few seconds. Please be advised that no removal of plastic zipper strap results in warranty void.



Picture 1: Plastic zipper strap as delivered from factory.



Picture 2: To cut the strap use pliers or other appropriate tool.



Picture 3: Finally remove the strap from the the dehumidifier.

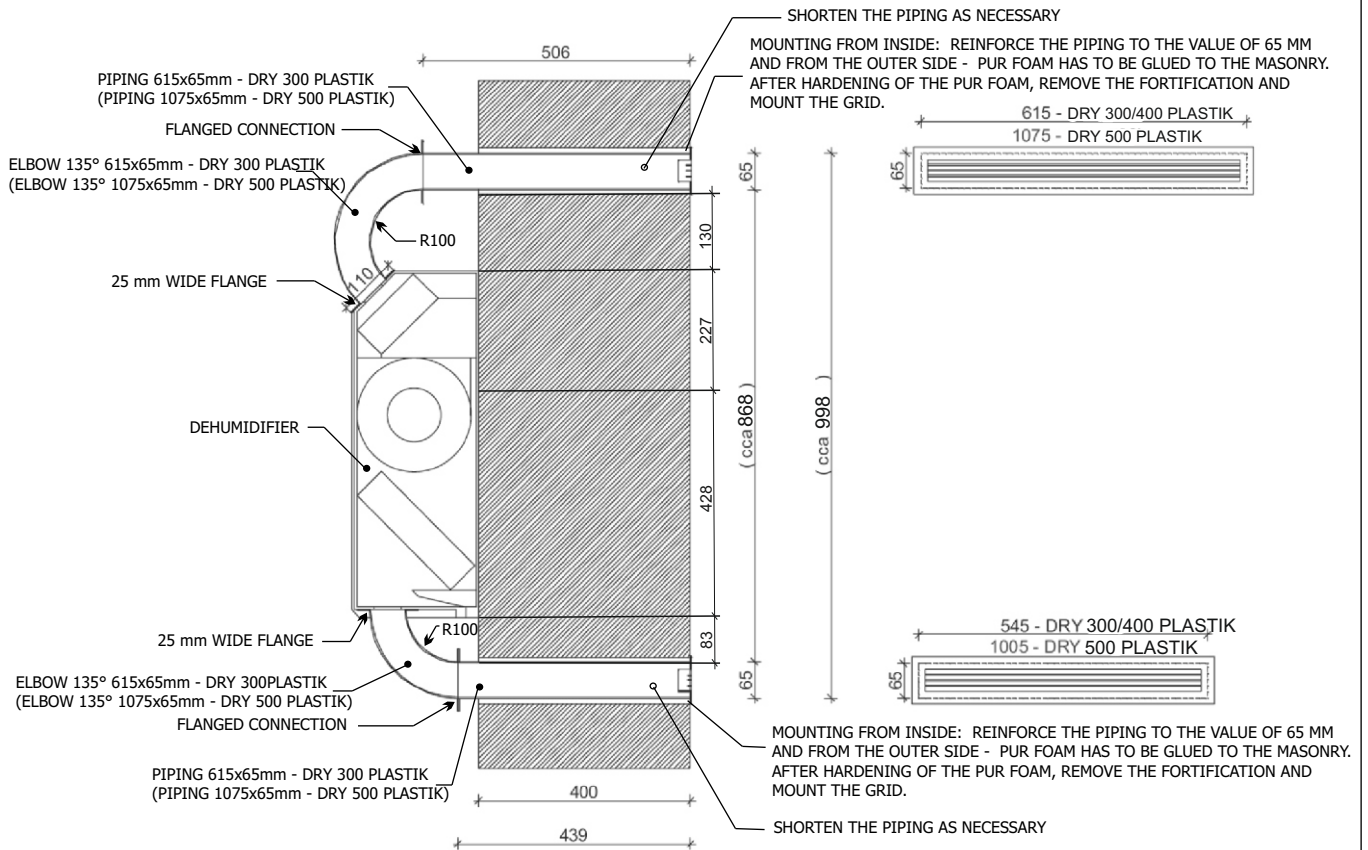

7. TECHNICAL DATA

DATA	UNIT	DRY 300	DRY 400	DRY 500
For swimming pools with max. water surface	m ²	30	45	60
Extraction rate at 30°C and 60% RH	l/24hrs	36	48	66
Extraction rate at 30°C and 70% RH	l/24hrs	43	53	83
Extraction rate at 30°C and 80% RH	l/24hrs	47,5	58	101
Operational temperature - standard	°C	22-35	22-42	22-35
Operational temperature - antifreeze stat	°C	15-35	15-42	15-35
Operational temperature - Thermostatic expansive valve (TEV)	°C	22-42	-	22-42
Operational temperature - antifreeze stat + TEV	°C	15-42	-	15-42
Operational temperature - hot gas defrost	°C	5-35	-	5-35
Operational humidity range	% RH	20-100	20-100	20-100
Air flow	m ³ /h	550	550	800
Noise level (in 1m distance)	dB (A)	42	42	44
Heat output	W	1900	1900	3500
Energy consumption	W	700	700	1000
Voltage	V/Hz/f	230/50/1	230/50/1	230/50/1
Operating / Starting current	A	3.1 / 15	3.1 / 15	4,5
Protection	A	10	10	16
Conductor	mm ²	CYSY 3C x 1,5	CYSY 3C x 1,5	CYSY 3C x 2,5
Condensed water pipe	mm	d 18	d 18	d 18
Dimensions netto (width x height x depth)	mm	PLASTIK (780 x 660 x 255), METAL&SILVER (780 x 642 x 300)	PLASTIK (780 x 660 x 255), METAL&SILVER (780 x 642 x 300)	PLASTIK (1245 x 660 x 255), METAL&SILVER (1245 x 642 x 300)
Dimensions brutto (width x height x depth)	mm	850 x 735 x 345	850 x 735 x 345	1315 x 735 x 345
Weight netto / brutto	kg	PLASTIK 40/ 46 kg, METAL 50 / 56 kg	PLASTIK 40/ 46 kg, METAL 50 / 56 kg	PLASTIK 60 / 69 kg, METAL 77 / 86 kg
Amount of refrigerant - R 410 A	kg	0,5	0,5	0,75
Max. pressures in the system HP/LP	bar	28,5/8,5	28,5/8,5	28,5/8,5

OUTPUT DIAGRAM OF DEHUMIDIFICATION (DRY 300 PLASTIK)

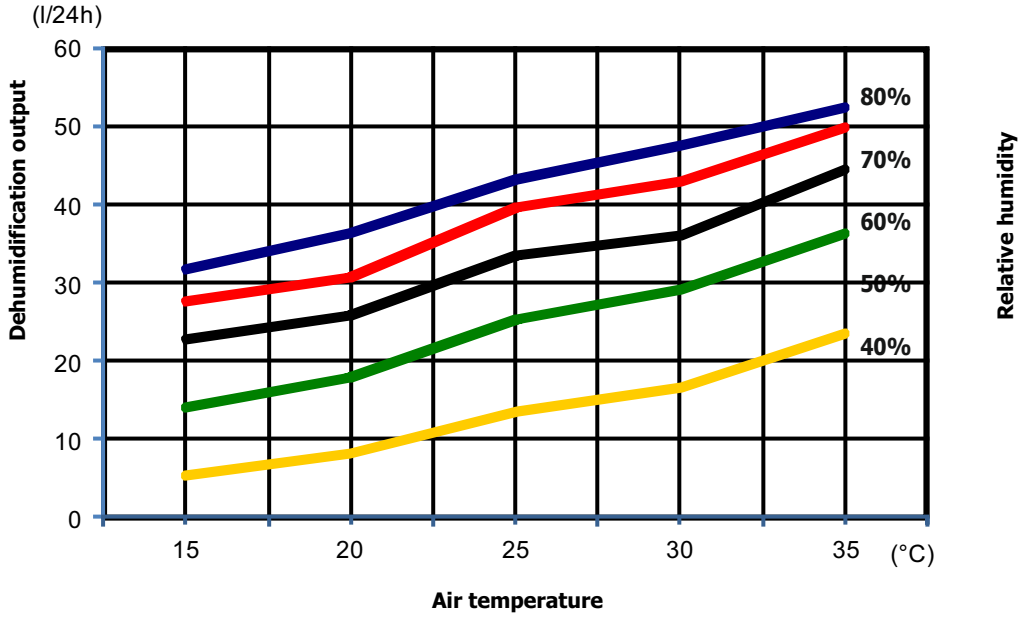

OUTPUT DIAGRAM OF DEHUMIDIFICATION (DRY 400 PLASTIK)

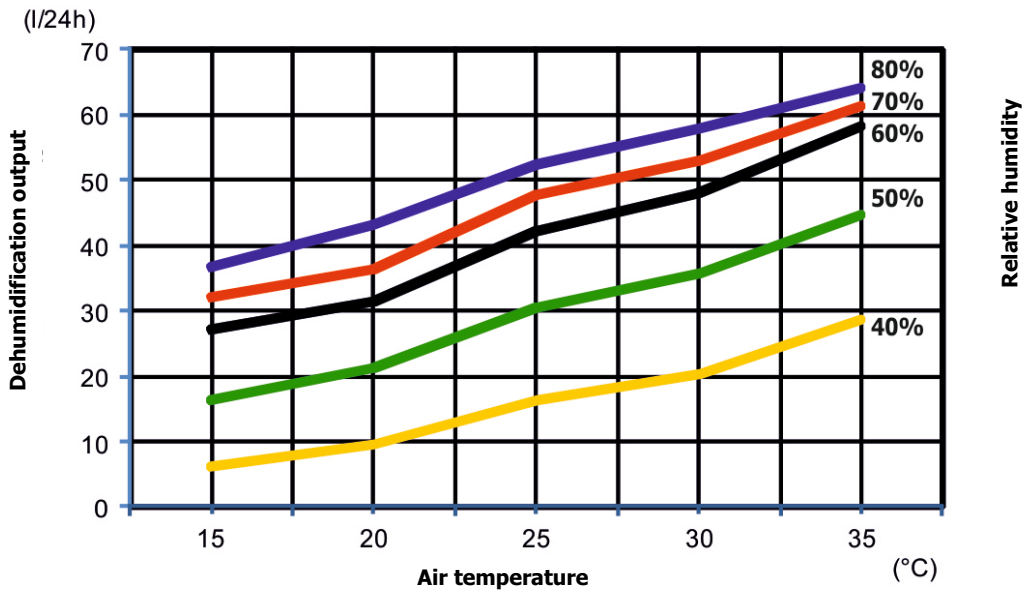

OUTPUT DIAGRAM OF DEHUMIDIFICATION (DRY 500 PLASTIK)

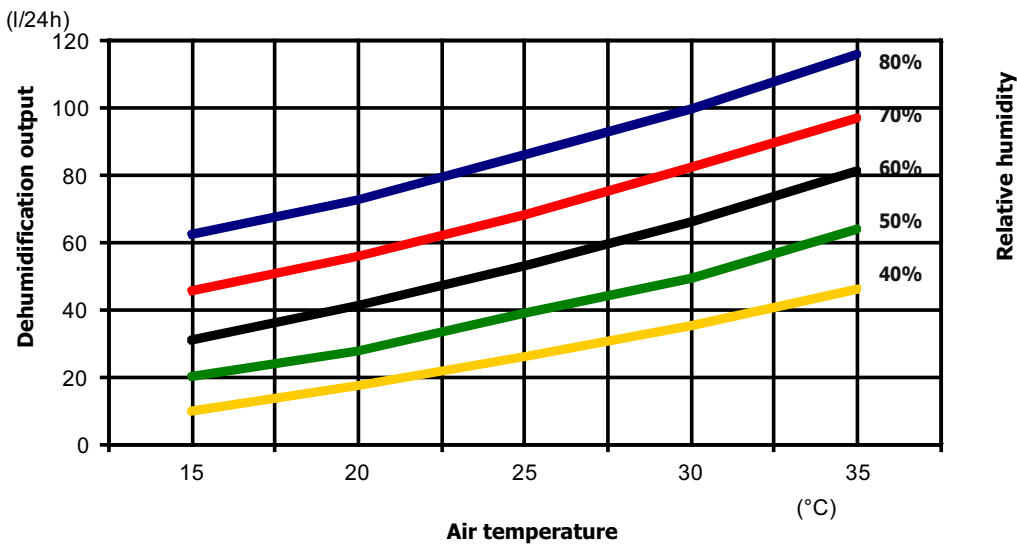

DIMENSIONS DRY 300/400 PLASTIK

FRONT VIEW

SIDE VIEW

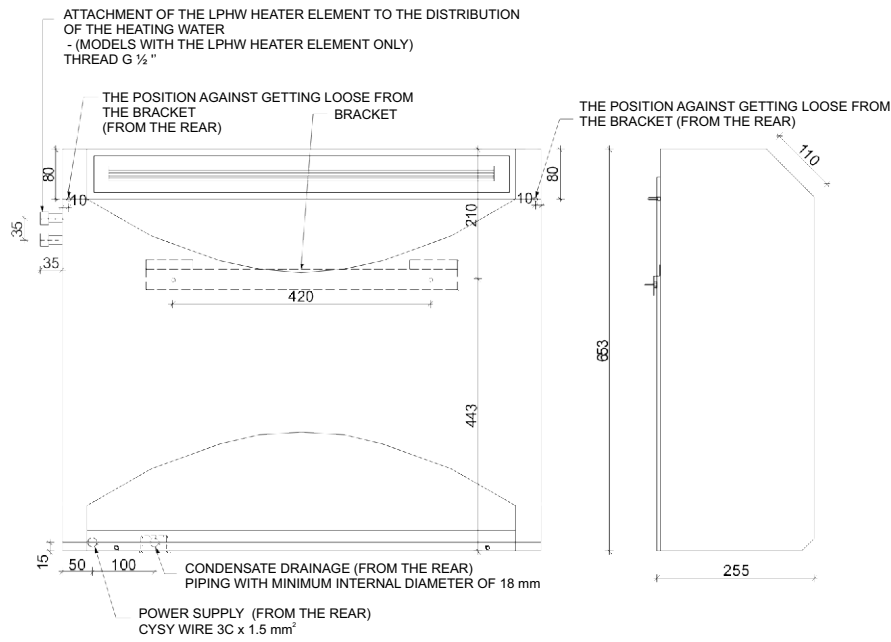

VIEW FROM BELOW

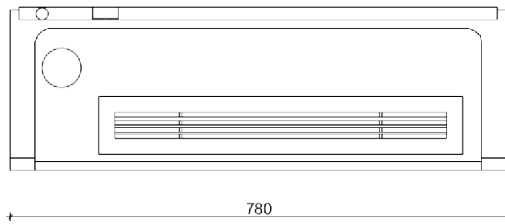

DIMENSIONS DRY 500 PLASTIK

FRONT VIEW

SIDE VIEW

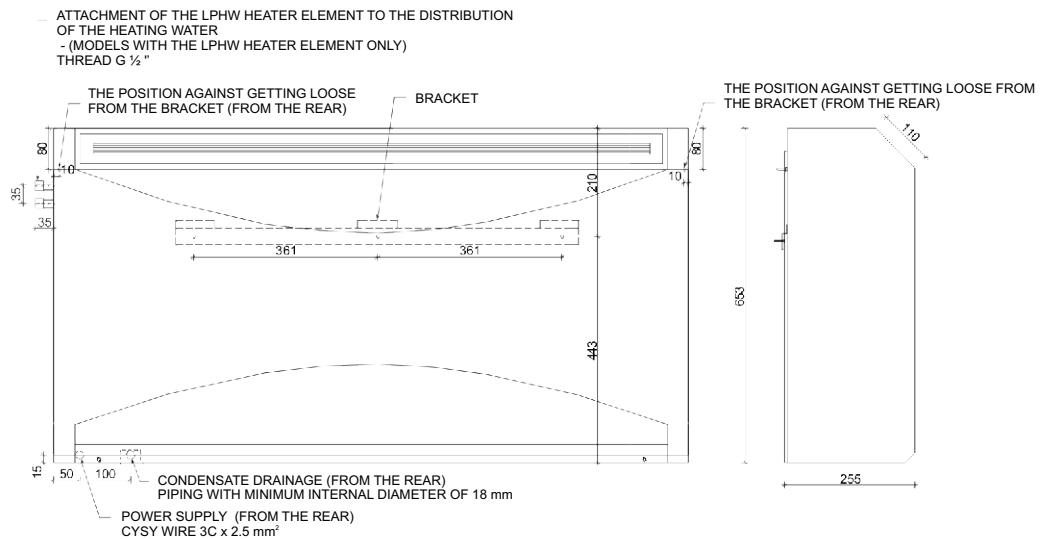

VIEW FROM BELOW

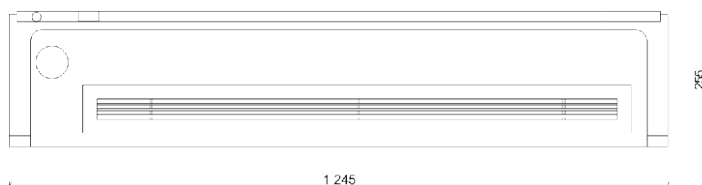

WIRING DIAGRAM OF MODEL MICROWELL DRY 300/400 PLASTIK

	DRY 300/400 Standard	DRY 300/400 EASY 200 / HYG 6001	DRY 300/400 LPHW / Solenoid
Wiring diagram	BASIC	1	2

DRY 300 BASIC

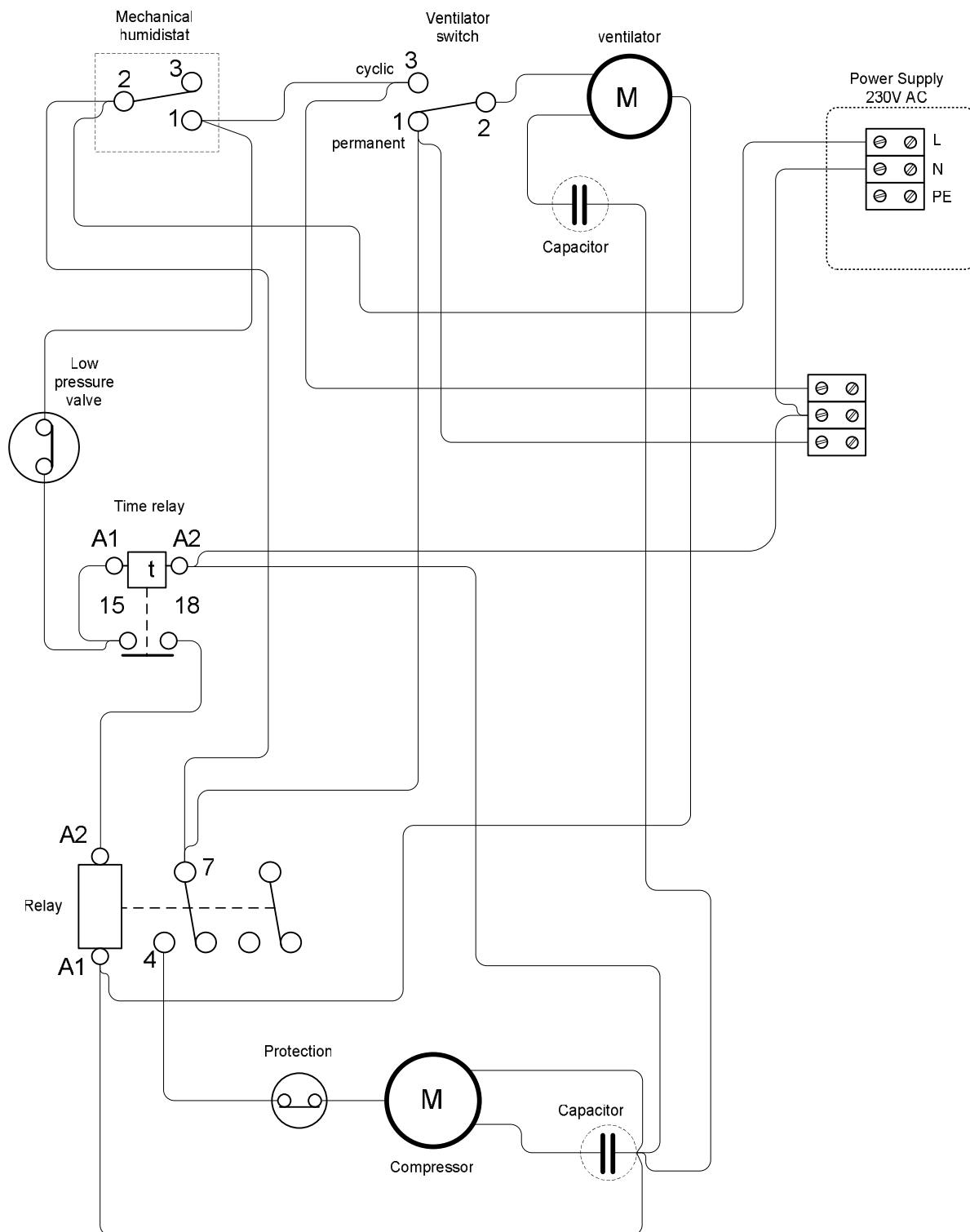

Note: Producer reserves right to make changes on wiring.

DRY 300.1

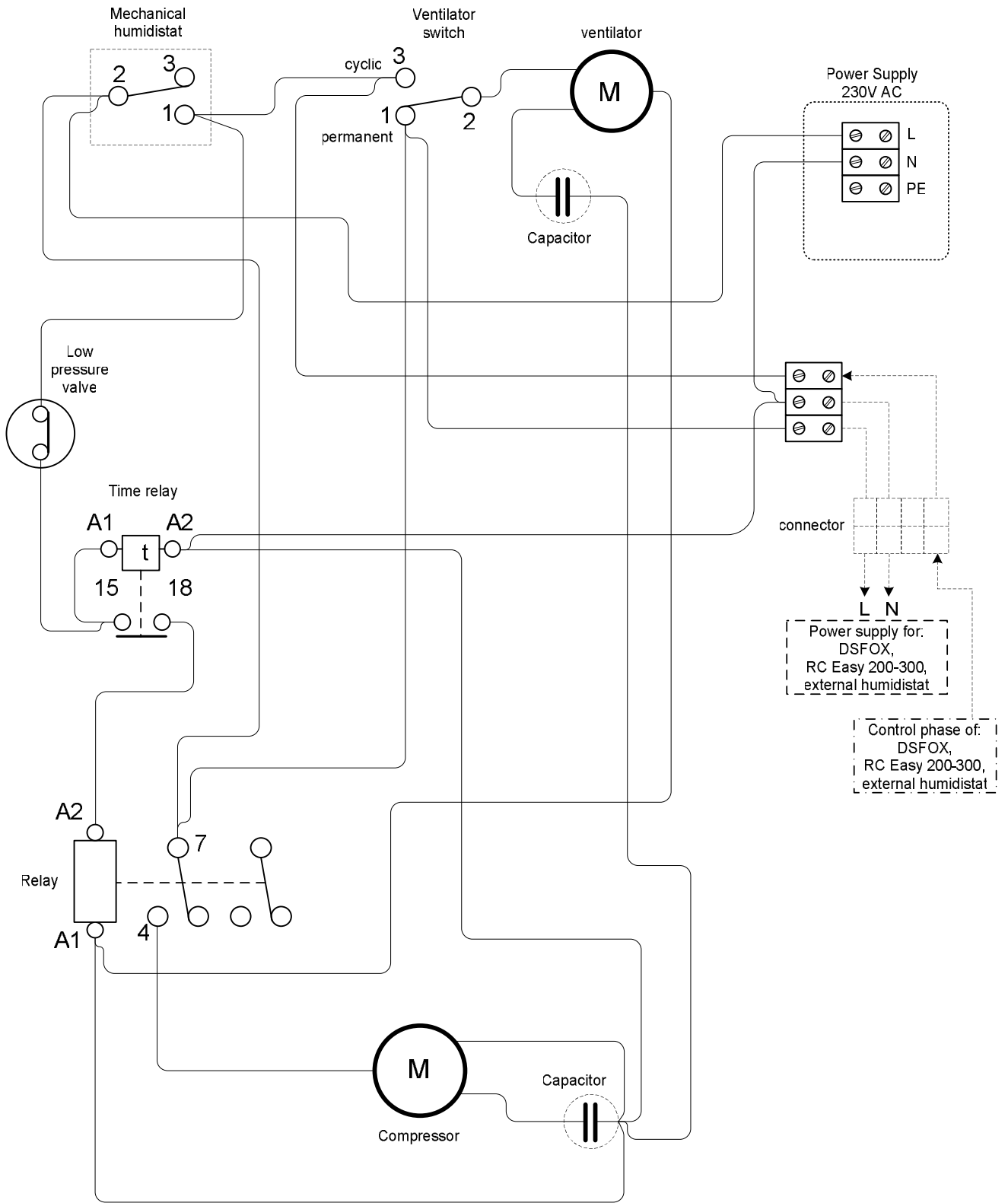

Note: Producer reserves right to make changes on wiring.

DRY 300.2

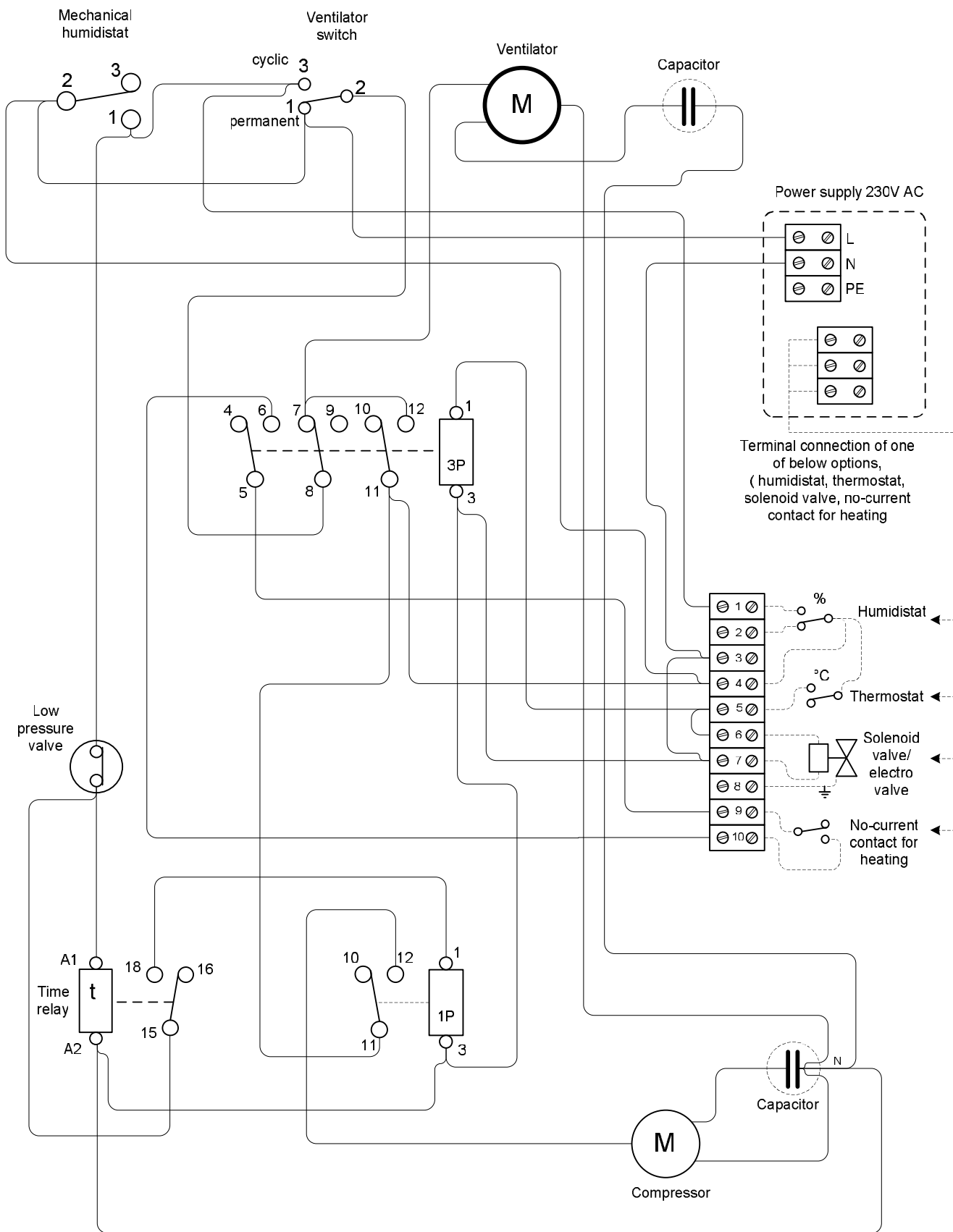

Note: Producer reserves right to make changes on wiring.

WIRING DIAGRAM OF MODEL MICROWELL DRY 500 PLASTIK

	DRY 500 Standard	DRY 500 EASY 200 / HYG 6001	DRY 500 LPHW / Solenoid
Wiring diagram	BASIC	1	2

DRY 500 BASIC

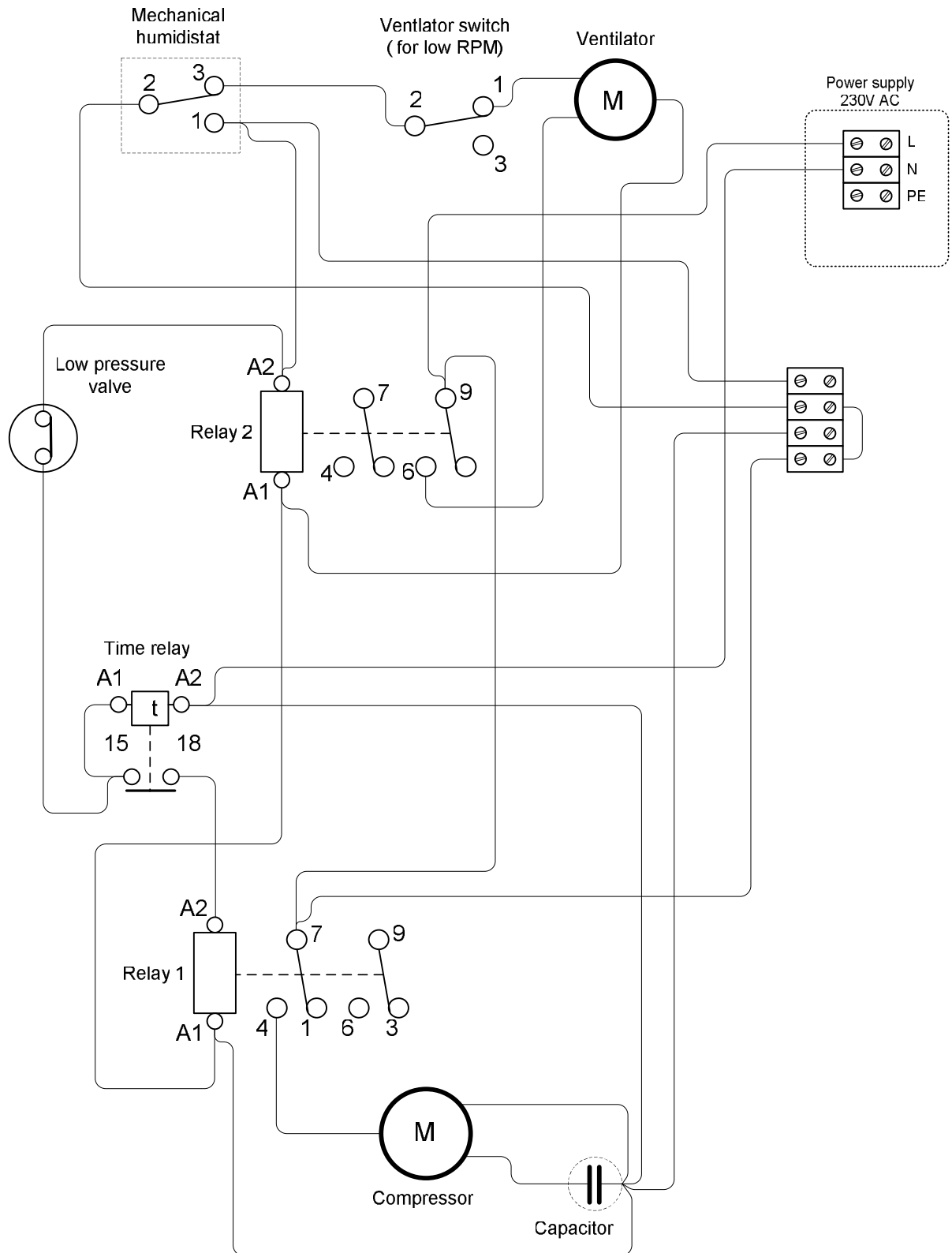

Note: Producer reserves right to make changes on wiring.

DRY 500.1

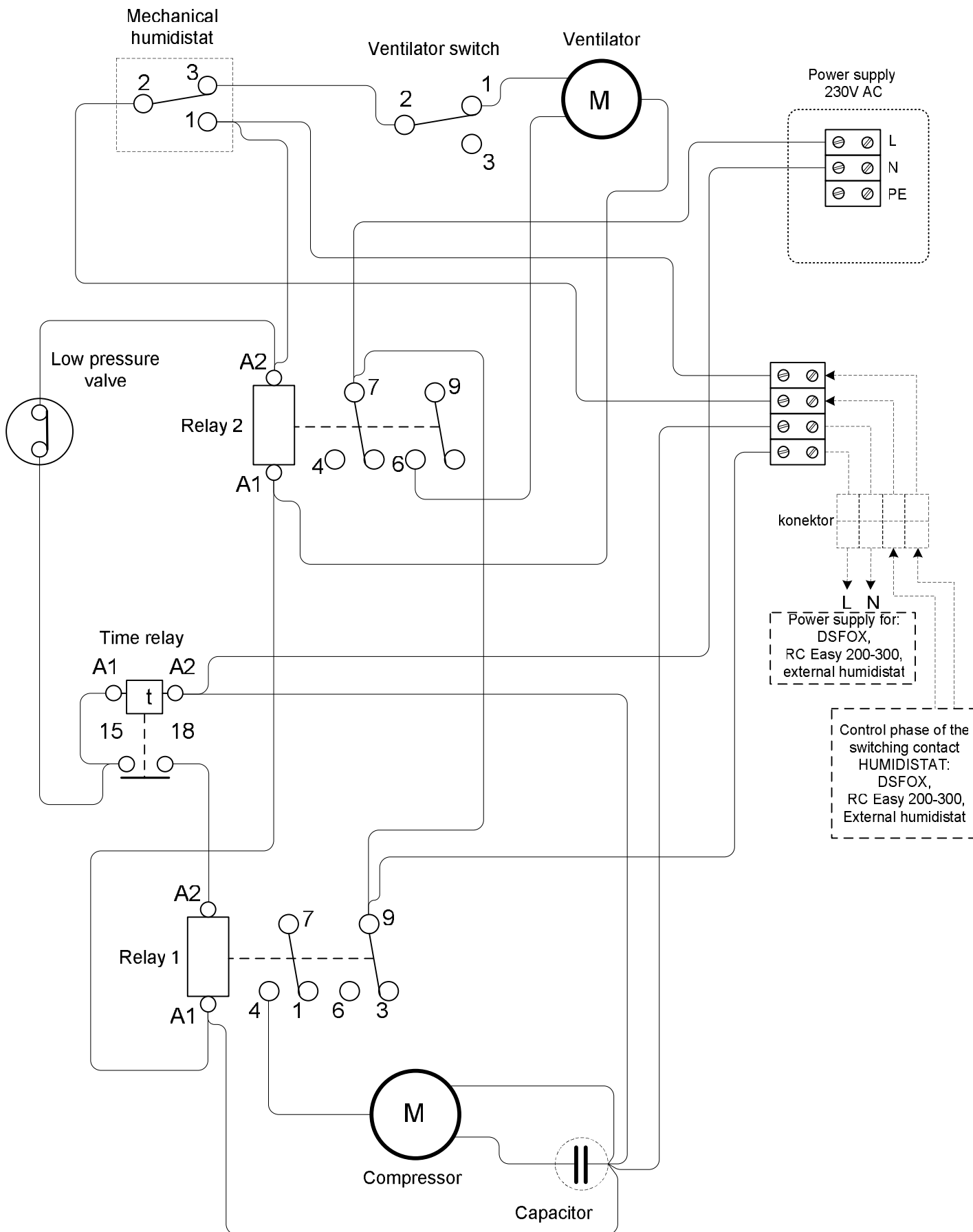

Note: Producer reserves right to make changes on wiring.

DRY 500.2

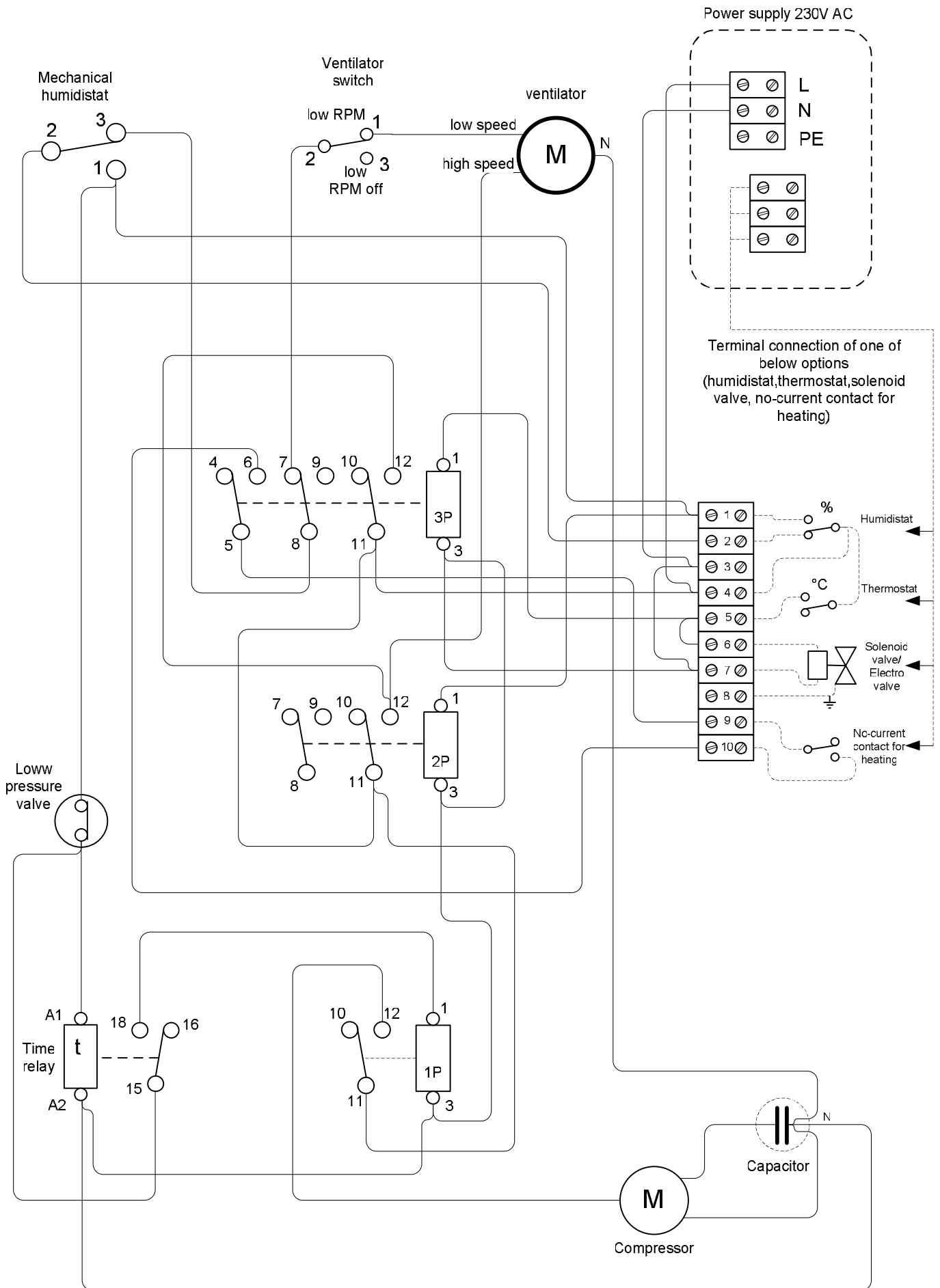

Note: Producer reserves right to make changes on wiring.

DRY 500.2 - X5.2 DRY EASY 300 , SOLENOID VALVE , NO-CURRENT CONTACT FOR HEATING

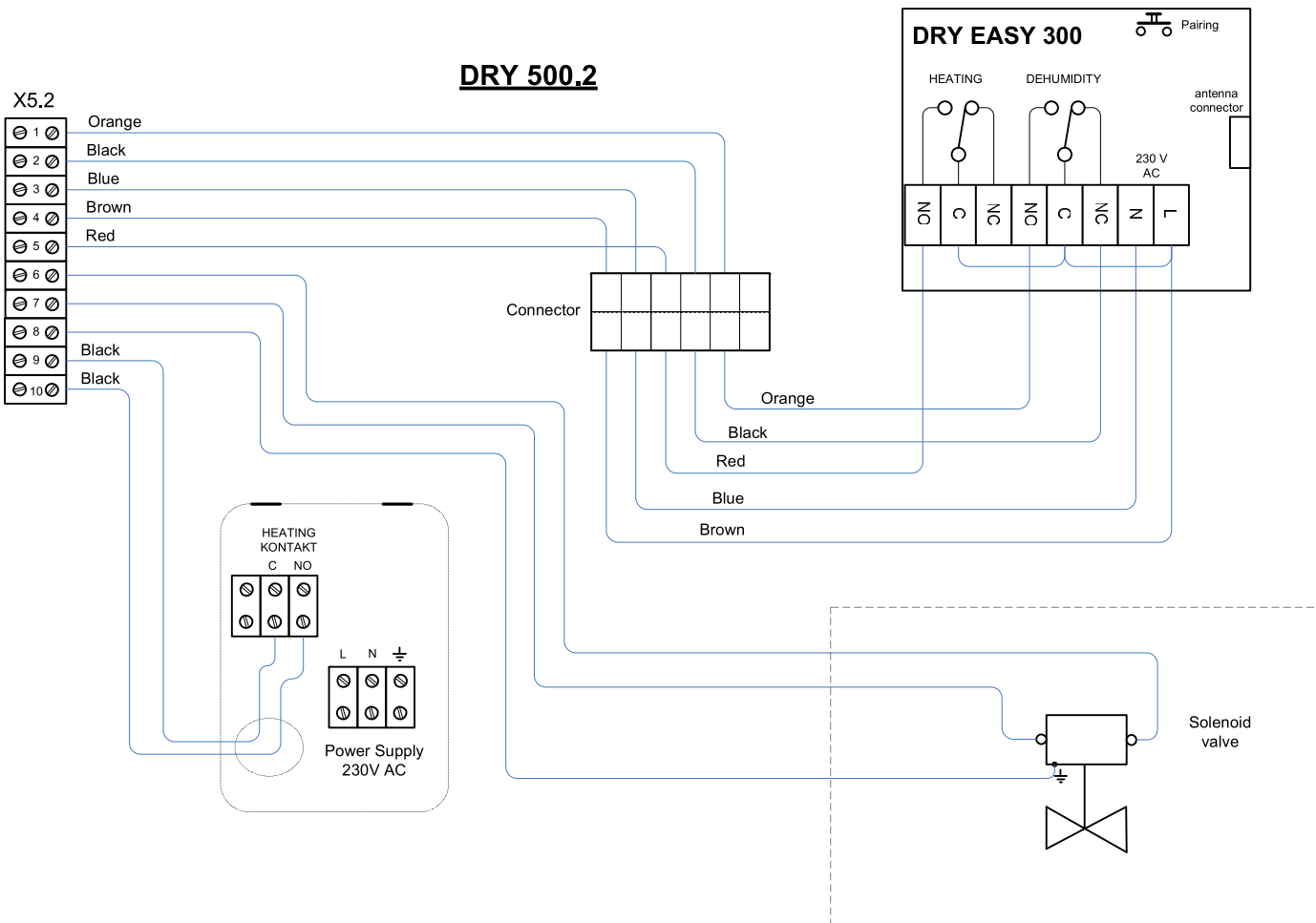

EXPANDED VIEW OF MODEL MICROWELL DRY 300/400 PLASTIK

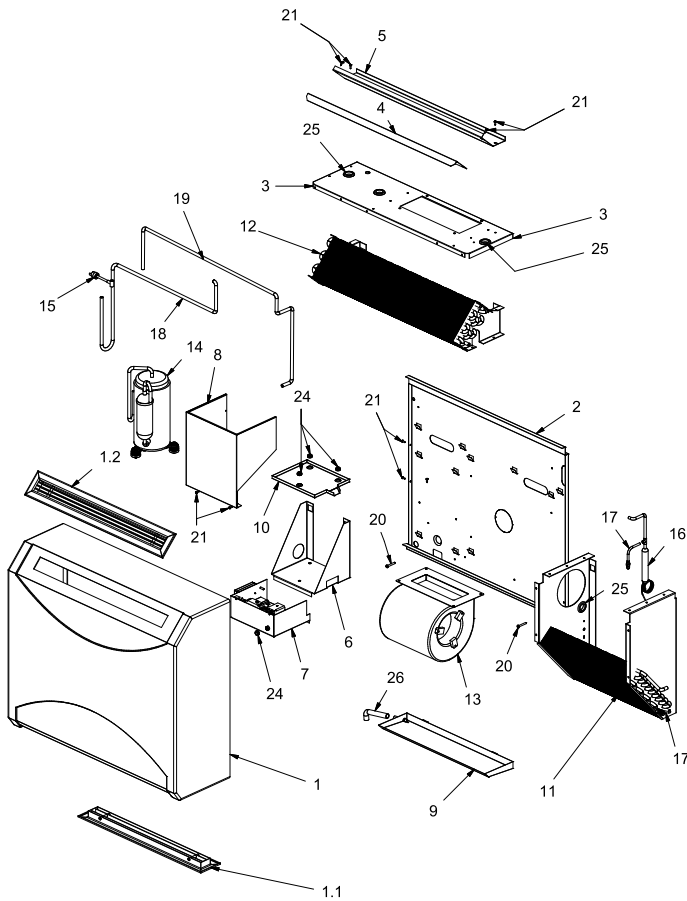

Position	Component	Number of pieces
1	Fiberglass cover	1
1,1	Inlet grid SMH2 20 1075 x 75	1
1,2	Outlet grid SMH2 12.5 1075 x 75	1
2	Back metal sheet	1
3	Ventilator metal sheet	1
4	Metal sheet in front of the exchanger	1
5	Metal sheet above the exchanger	1
6	Metal sheet under the compressor	1
7	Electro-box metal sheet	1
8	Compressor cover	1
9	Evaporator tray	1
10	Compressor tray	1
11	Exchanger 400 - evaporator	1
12	Exchanger 650 - condenser	1
13	Ventilator EBM D4-E133-DL01-D6	1
14	Compressor DAIKING YZG-E24RAY2	1
15	Low pressure valve Ranco HR00001 A5R703	1
16	Filter 20g d4/6mm	1
17	Filling valve, pipe d6, thread SAE 1/4"	2
18	Sunction pipe d10mm	1
19	Pressure pipe d6mm	1
20	Screw ST4.8 x 38	2
21	Screw 3.5 x 13	9
24	Rubber grommet d15 DA 110/150/10	4
25	Rubber grommet d30 DA 230/300/20	4
26	Condensate pipe d18x3, 1m	1

EXPANDED VIEW OF MODEL MICROWELL DRY 500 PLASTIK

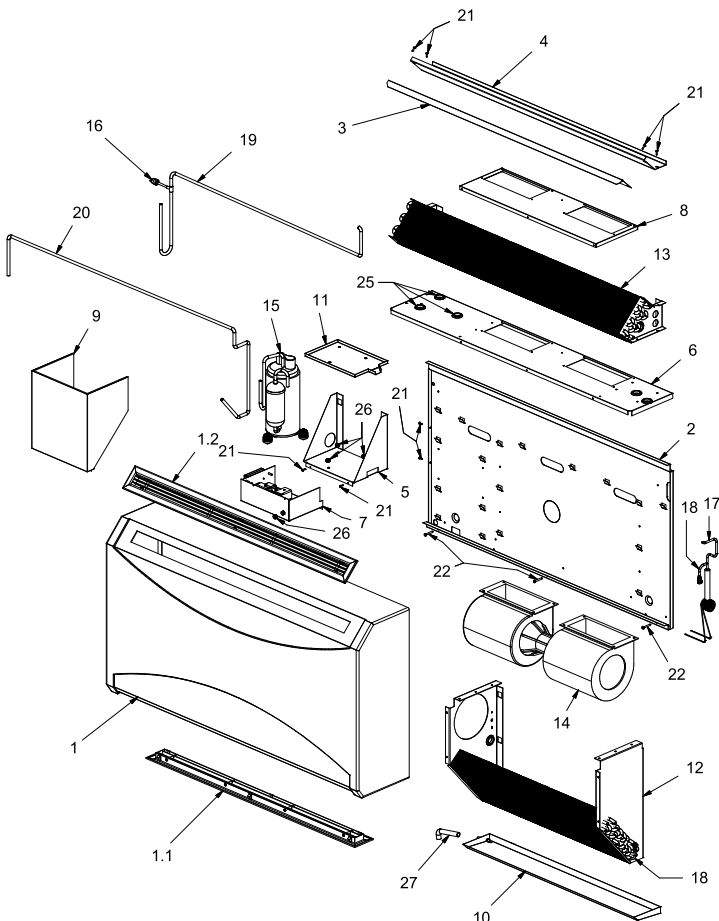

Position	Component	Number of pieces
1	Fiberglass cover	1
1,1	Inlet grid SMH2 20 1005 x 65	1
1,2	Outlet grid SMH2 12.5 1075 x 65	1
2	Back metal sheet	1
3	Metal sheet in front of the exchanger	1
4	Metal sheet above the exchanger	1
5	Metal sheet under the compressor	1
6	Ventilator metal sheet	1
7	Electro-box metal sheet	1
8	Holding metal sheet for ventilator	1
9	Compressor cover	1
10	Evaporator tray	1
11	Compressor tray	1
12	Exchanger 720 - evaporator	1
13	Exchanger 1115 - condenser	1
14	Ventilator EBM K4E146-AB73-21	1
15	Compressor DAIKING YZG-E35RY2	1
16	Low pressure valve Ranco HR00001 A5R704	1
17	Filter 30g d6/6mm	1
18	Filling valve, pipe d6, thread SAE 1/4"	2
19	Sunction pipe d10mm	1
20	Pressure pipe d6mm	1
21	Screw ST3.5 x 13	9
22	Screw ST4.8 x 38	3
25	Rubber grommet d30 DA 230/300/20	7
26	Rubber grommet d15 DA 11d180/10	4
27	Condensate pipe d18x3, 1m	1

8. WARRANTY CONDITIONS

The following exceptions stated by Microwell, Ltd. apply within the warranty.

No claims will be accepted if:

1. The dehumidifier is used in an incorrect way, not as described in this manual.
2. The dehumidifier is installed in an incorrect way, not as described in this manual.
3. The dehumidifier was put to operation by an unauthorized person.
4. The air flow through the dehumidifier is out of the defined borders.
5. The water flow through the dehumidifier is out of the defined borders.
6. The water's pH level and/or chemical condition is out of the defined borders:

Acidity / pH level:	pH	7,4 +/- 0,4
Total alkalinity, as CaCO ₃	ppm	80-120
Total hardness, as CaCo ₃	ppm	100-300
Total melted dry mass	ppm	max. 3000
Maximal saline content	wt/wt	6%
Free chlorine range	ppm	1,0-3,0
Superchlorination	ppm	max. 30 ppm/max. 24 hours
Bromine	ppm	2-3
Baquacil	ppm	25-50
Ozone	ppm	0,8-1,0
Maximum copper content	ppm	max. 2
Aquamatic single purifier	ppm	max. 2
Tarn clean purifier	ppm	max. 2
Sherwood purifier	ppm	max. 2

7. The dehumidifier suffered frost damage.
8. The electric tension source is insufficient or improper in any other way.

IN CASE OF ANY UNCERTAINTY YOU MAY HAVE, PLEASE FEEL FREE TO CONTACT US !

NOTE:

When applying applicable warranty, the registration card that ensures applicable warranties must be returned. In case you cannot find the registration card of your dehumidifier, please contact the Service department of Microwell, Ltd. - indicated your name, address and serial number of your dehumidifier. The registration card will be then sent to you for filling in. In case you have any service or technique related questions, please specify the model number and serial number of your dehumidifier. These information will help us in making proper diagnosing of your unit and the service can be performed with a minimum time delay.

TRANSPORT INSTRUCTIONS:

The dehumidifiers must be transported only in the original packaging and in a vertical position. Make sure that the dehumidifier cannot turn over or fall down during transportation. Do never put the dehumidifier aside! It may lead to serious **compressor damage!** No claims are accepted in case of any damage caused by transportation. When receiving the product delivered to you, please check whether the package is not damaged. If any kind of objections occurs, please make a proper documentation of them.

Technický skúšobný ústav Piešťany, š.p.

Notifikovaný orgán: Identifikačné číslo 1299

Notified Body: Identification No. 1299

Autorizovaný orgán: Reg. číslo SKTC 104 / SK03



Authorised Body: Reg. No. SKTC 104 / SK03

CERTIFIKÁT ZHODY CONFORMITY CERTIFICATE

Č./No.: 712990054

pre výrobcu alebo jeho autorizovaného zástupcu v Európskej únii
to the manufacturer or his authorised representative in the European Union

MICROWELL spol. s r.o.
SNP 2018/42
927 01 Šaľa, Slovak Republic

Výrobok a určenie typu / Product and designation of type

Odvlhčovač vzduchu MICROWELL
typ DRY 300 Plastik, DRY 500 Plastik,
DRY 300 Silver DRY 500 Silver,
DRY 300 Metal, DRY 500 Metal

Dehumidifier MICROWELL
type DRY 300 Plastik, DRY 500 Plastik,
DRY 300 Silver DRY 500 Silver,
DRY 300 Metal, DRY 500 Metal

Preskúšaná vzorka spĺňa základné požiadavky na bezpečnosť podľa nasledujúcich európskych smerníc Nového prístupu:

The sample tested meets the essential safety requirements of the following European New Approach Directives:

Smernica o EMC
Smernica o nízkom napätí

2004/108/EC
2006/95/EC

2004/108/EC
2006/95/EC

EMC Directive
Low Voltage Directive

Existujú pre to nasledujúce dokumenty:
záverečný protokol č.
750146/2007

For this the following documents exist:
Final Report No.
750146/2007

Dodržiujúc všetky príslušné smernice ES a poskytujúc ES Vyhlásenie výrobcu o zhode, vyššie uvedený výrobok môže byť opatrený označením CE.

Observing all relevant EC New Approach Directives and providing the Manufacturer's EC Declaration of Conformity above mentioned product can be labelled with CE marking.

CE



Piešťany 26.09.2007
750146

Ing. Anna ONDRÁŠIKOVÁ
riaditeľka posudzovania zhody výrobkov
Product Conformity Assessment Director

TSÚ Piešťany, š.p.
Krajinská cesta 2929/9
921 01 Piešťany
Slovenská republika

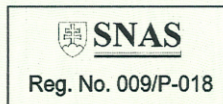

Telefón: +421 33 7957111
Fax: +421 33 7723716
e-mail: tsu@tsu.sk
web: www.tsu.sk

042129

CERTIFIKÁT ZHODY CONFORMITY CERTIFICATE

№./No. 141299025

pre výrobcu alebo jeho autorizovaného zástupcu v Európskej únii
to the manufacturer or his authorised representative in the European Union

MICROWELL s.r.o.
SNP 2018/42, 927 01 Šaľa
Slovenská republika / Slovak Republic

Výrobok a určenie typu

Bazénový odvlhčovač MICROWELL

Typ: **DRY 400 Plastik**
DRY 400 Metal
DRY 400 Silver

Product and designation of type

Swimming bath dehumidifier

Typ: **DRY 400 Plastik**
DRY 400 Metal
DRY 400 Silver

Výrobok spĺňa základné požiadavky na bezpečnosť podľa nasledujúcich európskych smerníc Nového prístupu:

Smernica o EMC	2004/108/EC
Smernica o nízkom napätí	2006/95/EC
Smernica o bezpečnosti strojov	2006/42/EC

The above mentioned type of product meets the essential safety requirements of the following European New Approach Directives:

2004/108/EC	EMC Directive
2006/95/EC	Low Voltage Directive
2006/42/EC	Machinery Directive

Existujú pre to nasledujúce dokumenty:
Záverečná správa o posúdení zhody
č. 140500010 zo dňa 18.02.2014

Certificate is issued on the basis of this document:
Conformity Assessment Report No. 140500010 date of issue 2014/02/18

CE označenie môže byť použité iba v prípade, že je posúdená zhoda so všetkými príslušnými smernicami Európskej komisie.

CE marking can be used only in the case of conformity assessment according to all relevant EC Directives, after working-out of the necessary technical documentation and after issuing of the conformity declaration.

Akkoľvek významné zmeny v zhotovení alebo konštrukcii výrobku, systéme kvality a dodatky k horeuvedeným technickým a právnym predpisom môžu viesť k neplatnosti certifikátu. Zodpovednosť za výrobok zostáva na výrobcovi alebo jeho splnomocnenom zástupcovi

Any significant change in product's form or construction, system of quality and supplements to above mentioned technical and legal provisions can result in invalidity of the certificate. Producer or his authorised representative is responsible for the product.



Vydany dňa: 19.02.2014
Date of issue: 19 Februar 2014

Ing. Janka LEVICKÁ
vedúca certifikačného orgánu
certifikujúceho výroby
Head of Product Certification Body

MICROWELL, spol. s r.o.

SNP 2018/42

927 01 Šaľa, Slovakia

Phone: +421 31 7020 540-1

Fax: +421 31 7020 542

E-mail: microwell@microwell.sk

www.microwell.eu

Distributed by: