

FILTREAU™ UVC

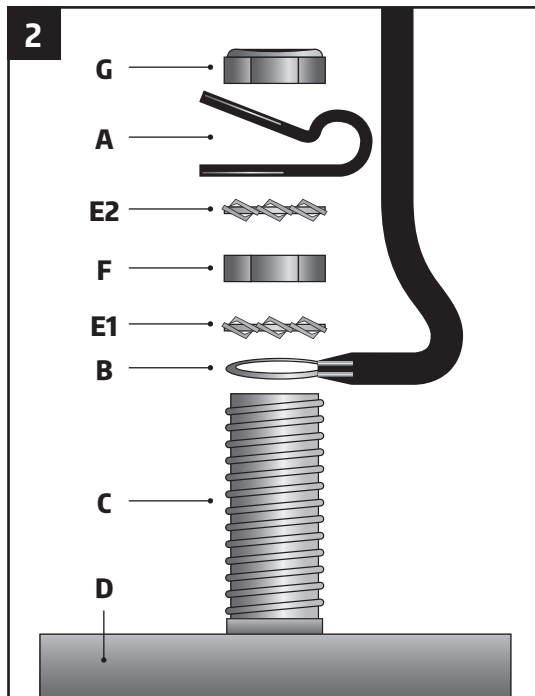

OZONE
80W / 120W AMALGAM

M A N U A L

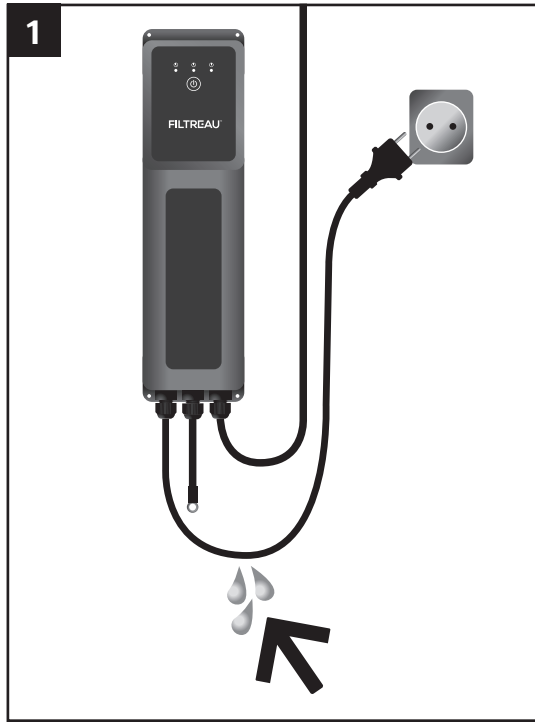

3

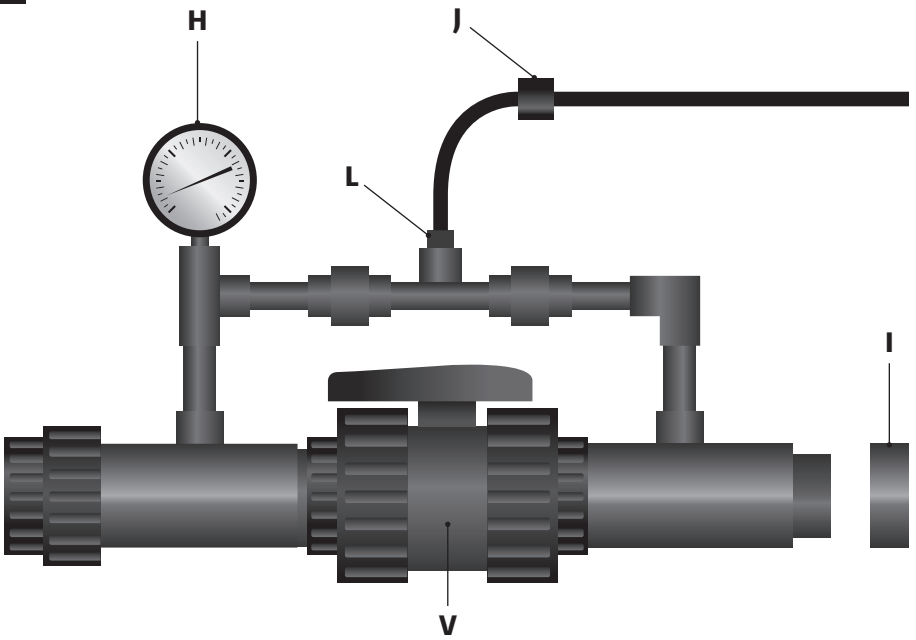

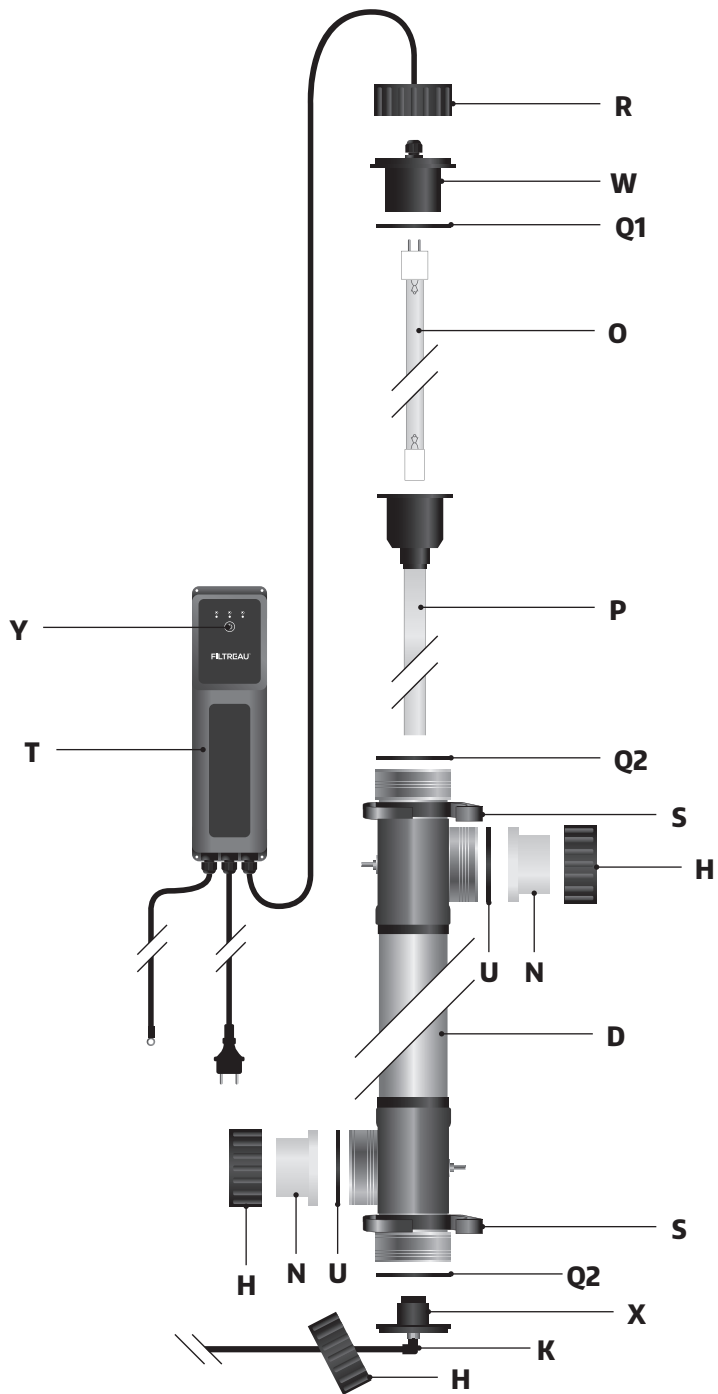

FILTREAU UV-C OZONE 80W/120W AMALGAM

WHAT DOES OZONE DO?

Ozone is one of the most effective water treatment sterilizers.

Ozone has a very strong oxidation and sterilization effect on all organic substances and eliminates objectionable odors. It is for exactly these reasons that it has been used to disinfect drinking water and air for decades and is used in the food industry. Combined with UV-C radiation, this results in clean, oxygen rich, crystal clear water. The ozone molecule, O₃, oxidizes micro-organisms such as fungi, bacteria (incl. legionella), parasites, algae, viruses and even urine, perspiration, cosmetics, sunscreens, etc.!

Once ozone has reacted and done its job, it disappears from the water without even leaving any by-products behind. As a result, the use of various chemicals can be minimized by up to 90%!

HOW IT WORKS

The Filtreau UV-C Ozone is placed in the piping of your filter line. The water must be fed to the device through the venture unit by a pump. Air is automatically drawn in by the water pressure of the water in the venture. The water pressure can be read on the pressure gauge and is adjustable via the ball valve. The ideal water pressure is between 0.4 and 0.7 bar. The ozone that remains between the quartz sleeve and the ozone UV-C lamp is then drawn through the venture unit and mixed in the water. This is when the very powerful oxidation and sterilization of the water occurs. Then the ozone-charged water passes the DUPLEX housing and is exposed to the powerful UV-C radiation, 35% of which is also reflected by the polished interior. All the ozone particles that have done their work are broken down by this radiation and converted into oxygen. As such, after passing the UV-C radiation, there is no residual ozone in your water.

Due to the extra wide DUPLEX housing, water has extra-long contact time with both the ozone particles and the UV-C radiation, resulting in extremely efficient operation!

An additional advantage of the extra wide DUPLEX housing is that it results in minimum pressure loss and is completely resistant to saltwater.

SAFETY AND INSTALLATION REQUIREMENTS

- See the **Technical Specifications** for the required voltage and current.
- The device may only be connected to an electrical installation that meets the legal requirements. A GFCI (30ma) and earthed sockets are required. If in doubt always use a certified electrician to install.
- The device, the electronics box, the plug and the power cord must be positioned at least 2m from the tank.
- Always keep the plug free from moisture. Ensure that water cannot track down the power cord to the socket. (See figure 1 for how to loop the power cord).
- Never submerge the device in liquid.
- The device can withstand a maximum pressure of 3 bar.
- The device is suitable for fresh and salt water.
- The device is designed to operate with a water temperature between 0 and 40 degrees C. Outside these temperatures the device must be completely disconnected from the water.
- Before use, check the whole device, power cord and plug for damage. In case of any damage, the device must not be used. Please let your dealer assess any damage.
- The device may only be connected if there is a sufficient flow of water.
- To avoid possible harm to eyes or skin, the working of the UV-C Ozone lamp should only be checked through the transparent parts of the device. (The system will indicate if the lamp needs to be changed).
- The special lamp generates ozone, which has a strong smell even in very small quantities. Higher concentrations of ozone can be harmful to the eyes, nose and skin. Therefore always check the system for leakage. Proper installation and proper positioning of the O-rings are of great importance.
- During maintenance, the device and pump must be disconnected from the mains. Be aware that the device and the lamp can remain hot for up to 10 minutes after being disconnected.

EARTHING THE DEVICE; SEE FIGURE 2

1. Place the strain relief clip (A) about 10-12cm from the eye of the earth cable (B).
2. Slide the eye of the earth cable (B) over the earth pin (C) that is fastened to the housing (D).
3. Slide the first spring washer (E1) over the earth pin (C).
4. Place the hexagonal nut (F) on the earth pin and tighten it.
5. Slide the second spring washer (E2) over the earth pin (C).
6. Slide the strain relief clip (A) over the earth pin (C).
7. Place the last lock nut (G) on the earth pin (C) and tighten it carefully with a spanner #8.
8. Ensure that the sequence follows precisely that shown in figure 2.

INSTALLATION OF THE DEVICE; SEE FIGURE 3/4

The device must be placed in a dry, well-ventilated area and in such a way as to prevent exposure to direct sunlight. Never place the device immediately after the PH controller and/or salt electrolysis. The best location is – if possible – after the filter. It must always be installed in the vertical position. The electronic ballast (T) must remain visible so the UV-C lamp replacement indicator can be seen. Also consider accessibility in connection with maintenance (see also Maintenance and disassembly).

VENTURI UNIT (SEE FIGURE 3/4)

1. Screw the pressure gauge (H) onto the venturi unit hand-tight. Use Teflon tape (not included).
2. Glue the venturi unit into the PVC piping using the supplied glue coupling (T), before or at the device's inlet. Keep in mind that the venturi unit must be installed horizontally.
3. Take the hose with the non-return valve (J). Attach the long section of the hose to the air valve (K) at the bottom of the device. Attach the short section of the hose on the hose nipple (L) of the venturi unit.

DEVICE (SEE FIGURE 3/4)

1. Unscrew the lock nut (M) from the housing (D) and save it for attachment of the connection coupling (N) in step 7.
2. Carefully remove the UV-C lamp (O) from its packaging and insert it into the quartz sleeve (P).
3. Insert the UV-C lamp (O) into the lamp holder (L) and then push the assembly further into the quartz sleeve (P). Also always ensure that the O-rings (Q1 & Q2) are positioned correctly.
4. Screw the nut (R) back onto the housing (D) hand-tight.
5. Install the pipe clamps (S) at the desired location. This is where the device will be mounted. (Keep the length of the cables in mind when selecting this location; see also step 6).
6. Mount the electronic ballast (T) at the desired location. (Keep the length of the cables in mind).
7. Use the lock nut (M) to screw the connection coupling (N) onto the housing (D), and ensure that the O-rings (U) are positioned properly.
8. Place the device in the pipe clamps (S) and glue the connection coupling (N) to the piping and/or the venturi unit.
9. Ensure that enough water is flowing through the device, and then plug the plug into the designated socket. All the lights on the electronic ballast (T) will light up, after which the green light will remain on. The transparent connectors (N) enable you to see whether the UV-C lamp (O) is on. Also check everything for leaks.
10. Once the entire system is leak-free, the amount of ozone can be adjusted by means of the ball valve (V) on the venturi unit. The ideal water pressure on the pressure gauge (H) is 0.4 to 0.7 bar.
11. The device can be switched off by simply unplugging the plug from the socket. The electronic ballast remembers the number of hours the lamp has been lit.

MAINTENANCE AND DISASSEMBLY

The device needs maintenance at least once per half year. During maintenance, the device must be disconnected from the mains. Chalk deposits and possibly algae must be removed from the quartz sleeve (P) and the housing (D). The UV-C Ozone lamp (O) only has to be changed after 8,000 hours of use. The actual lifetime is dependent on the number of times it is turned on and off. The electronics will indicate when the lamp has been on for 8,000 hours.

1. Unplug the device from the mains and close the pipes.
2. Ensure that the water is drained out of the device.
3. Loosen the bolt (R) and disconnect the UV-C Ozone lamp (O) from the lamp holder (W). If necessary, you can also replace the lamp (see point 10 to reset).
4. Carefully raise the quartz sleeve (P).
5. The quartz sleeve (P) can be cleaned with an appropriate cleaner. After cleaning, rinse the quartz sleeve (P) thoroughly. Use a soft cloth to avoid scratches!
6. The housing (D) can now also be cleaned. This can be done with a brush; do not use any chemicals.
7. After cleaning, place the quartz sleeve (P) back in the housing (D). Ensure that the O-ring (Q1 & Q2) is seated properly and that the quartz sleeve (P) slides into the sleeveholder (X).
8. Put the UV-C Ozone lamp (O) into the lamp fitting (W) and slide both into the quartz sleeve (P).
9. Tighten the nut (R) on the housing (D) hand-tight. (See 9 under Installation of the device).
10. After changing the UV-C Ozone lamp (O), the device needs to be reset. To do this, press and hold button (Y) on the electronics box (T) for 5 seconds. After this the green light will come on.

N.B. To change the housing and/or the electronics box, the earth must be completely disconnected. The component parts must be saved because they do not come with a new housing or electronics as standard.

If in any doubt seek the advice of a certified electrician!

TYPES OF FILTREAU UV-C OZONE

Part No.: UVO0001	Filtreau UV-C Ozone 80W (230V; 50/60Hz)
Part No.: UVO0002	Filtreau UV-C Ozone 120W Amalgam (230V; 50/60Hz)

SPARE PARTS

Part No.: EPO0001	Electrical part Filtreau UV-C Ozone 80W
Part No.: EPO0002	Electrical part Filtreau UV-C Ozone 120W Amalgam
Part No.: QS0004	Quartz sleeve tbv Ozone 80W/120W Amalgam
Part No.: HOU0010	Housing Filtreau UV-C Ozone 80W/120W Amalgam
Part No.: RLO0001	Lamp Filtreau UV-C Ozone 80W
Part No.: RLO0002	Lamp Filtreau UV-C Ozone 120W Amalgam
Part No.: 3001046	Venture system Filtreau UV-C Ozone
Part No.: 3001045	Check-valve VITON

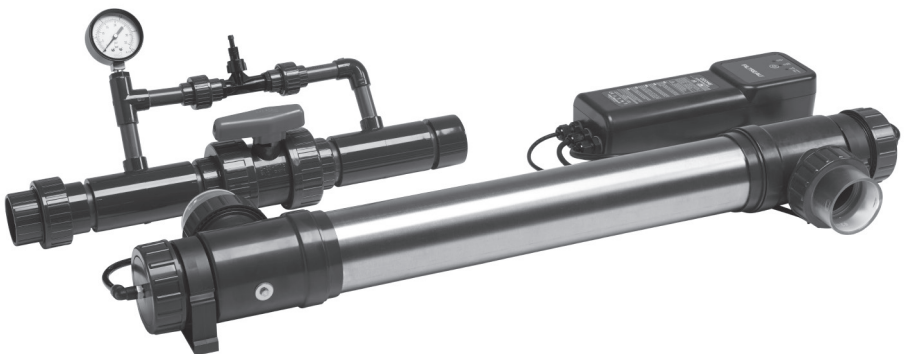

WARRANTY CONDITIONS

- The supplier guarantees the Filtreau UV-C Ozone 80W/120W Amalgam for 24 months after date of purchase against defects in materials or manufacturing faults. The UV-C lamp and quartz housing are not covered by this warranty.
- Defects and/or breakdowns as the result of incorrect installation, use and/or maintenance are not covered by this warranty.
- The warranty is void if repairs are carried out by third parties.
- The warranty is void if the cabling is not in its original condition.
- The warranty is only valid if a valid, dated proof of purchase is provided, stamped by the supplier.
- The supplier is not responsible for damage, including possible consequential damage, caused by the improper use or failure of the device.
- Claims relating to transport damage to the device and/or parts will only be processed if the damage is reported to the dealer within 24 hours, in writing.



RECYCLE INFORMATION

The symbol of the barred bin printed on the product means that it must be collected separately from other rubbish when it will not be anymore in use. The user, at the end of the life of the product, will have to bring it to a proper rubbish collection centre for electric and electrical devices. Alternatively he can return the used product to the seller at the moment he buys a new unit, but only in proportion 1 to 1. A differentiated refuse collection is environmentally friendly and it helps the recycle of the materials, any other collection procedure is unlawful and will be subject to the law in force.

www.filtreau.nl

Made in The Netherlands

